



Chipsmall Limited consists of a professional team with an average of over 10 year of expertise in the distribution of electronic components. Based in Hongkong, we have already established firm and mutual-benefit business relationships with customers from,Europe,America and south Asia,supplying obsolete and hard-to-find components to meet their specific needs.

With the principle of “Quality Parts,Customers Priority,Honest Operation,and Considerate Service”,our business mainly focus on the distribution of electronic components. Line cards we deal with include Microchip,ALPS,ROHM,Xilinx,Pulse,ON,Everlight and Freescale. Main products comprise IC,Modules,Potentiometer,IC Socket,Relay,Connector.Our parts cover such applications as commercial,industrial, and automotives areas.

We are looking forward to setting up business relationship with you and hope to provide you with the best service and solution. Let us make a better world for our industry!



Contact us

Tel: +86-755-8981 8866 Fax: +86-755-8427 6832

Email & Skype: info@chipsmall.com Web: www.chipsmall.com

Address: A1208, Overseas Decoration Building, #122 Zhenhua RD., Futian, Shenzhen, China



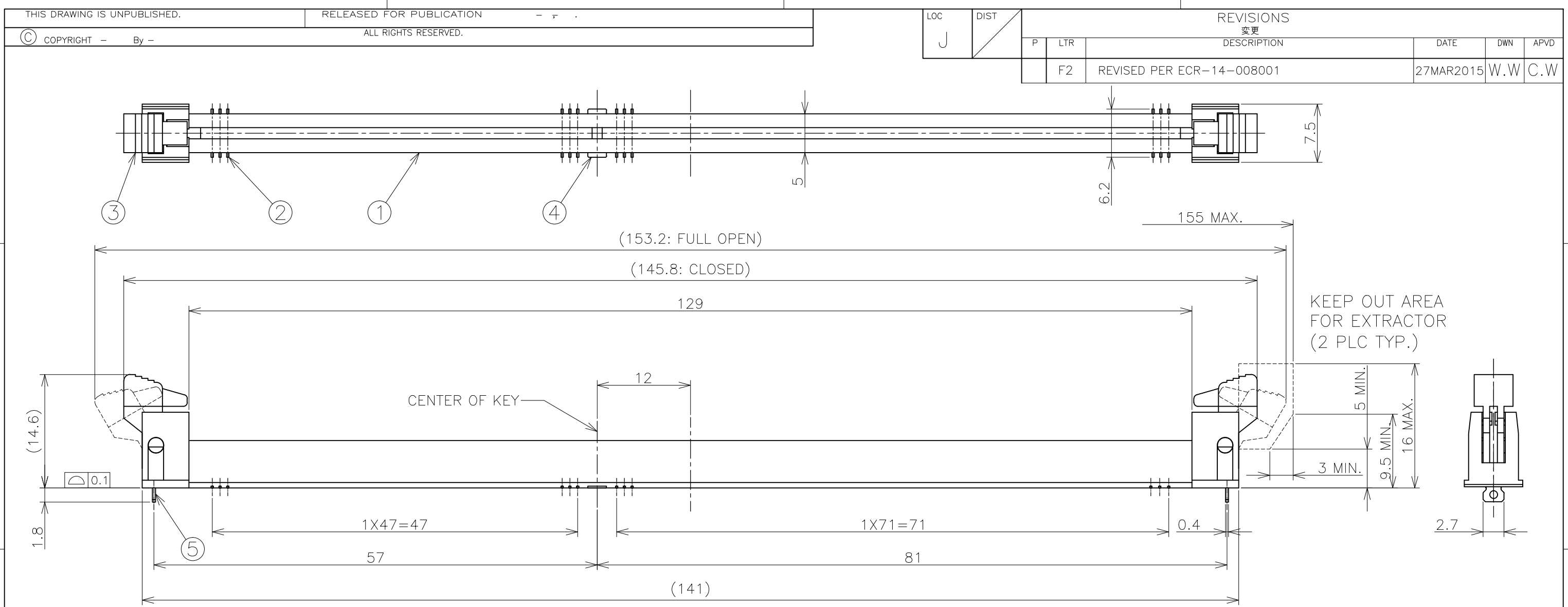

2	SIDE TAB	5
1	CENTER PEG	4
2	EXTRACTOR	3
240	CONTACT	2
1	HOUSING	1
QTY	ITEM	ITEM NO.

NOTES; (APPLIED TO SHEET 1-3)

- 1. MATERIAL ; HOUSING: HIGH TEMPERATURE THERMO PLASTIC UL94V-0
CONTACT: COPPER ALLOY
EJECOR: HIGH TEMPERATURE THERMO PLASTIC UL94V-0
PEG/TAB: COPPER ALLOY
- △ FINISH ; SEE TABLE.
- △ COPLANARITY: 0.1 MAX. (BEFORE SOLDERING)
- 4. CONFORMS TO REQUIREMENTS OF EIA/ECA-361-1000.01A.
(CONTROLLED ENVIRONMENT APPLICATIONS
AND TE PRODUCT SPECIFICATION 108-78570)
- 5. REFERENTIAL REFLOW PROFILE IS APPLIED BY J-STD-020*.
- △ LOW RESISTANCE TYPE.
- 7. EXTRACTORS SHOULD BE FULLY CLOSED BEFORE REFLOW.

GENERAL TOERLANCE

10 ≥	±0.2
30 ≥	>10 ; ±0.3
100 ≥	>30 ; ±0.5
ANGLE	±3°

△	BLACK	BLACK	Au PL.: 0.00038mm MIN. (CONTACT AREA) Au FLASH PL.: SOLDERING AREA (CONTACT TINE, PEG) TIN PL.: SOLDERING AREA (TAB) Ni UNDER PL.: 0.002mm MIN. ALL OVER	240	3-2134250-2
△	WHITE	BLACK	Au PL.: 0.00051mm MIN. (CONTACT AREA) Au FLASH PL.: SOLDERING AREA (CONTACT TINE, PEG) TIN PL.: SOLDERING AREA (TAB) Ni UNDER PL.: 0.002mm MIN. ALL OVER	240	1-2134250-6
	BLACK	BLACK	Au PL.: 0.00076mm MIN. (CONTACT AREA) Au FLASH PL.: SOLDERING AREA (CONTACT TINE, PEG) TIN PL.: SOLDERING AREA (TAB) Ni UNDER PL.: 0.002mm MIN. ALL OVER	240	1-2134250-5
	WHITE	BLACK	Au PL.: 0.00038mm MIN. (CONTACT AREA) Au FLASH PL.: SOLDERING AREA (CONTACT TINE, PEG) TIN PL.: SOLDERING AREA (TAB) Ni UNDER PL.: 0.002mm MIN. ALL OVER	240	1-2134250-4
	BLACK	BLACK	Au PL.: 0.00038mm MIN. (CONTACT AREA) Au FLASH PL.: SOLDERING AREA (CONTACT TINE, PEG) TIN PL.: SOLDERING AREA (TAB) Ni UNDER PL.: 0.002mm MIN. ALL OVER	240	1-2134250-3
	WHITE	BLACK	Au PL.: 0.00038mm MIN. (CONTACT AREA) Au FLASH PL.: SOLDERING AREA (CONTACT TINE, PEG) TIN PL.: SOLDERING AREA (TAB) Ni UNDER PL.: 0.002mm MIN. ALL OVER	240	1-2134250-2
	BLACK	BLACK	Au PL.: 0.00038mm MIN. (CONTACT AREA) Au FLASH PL.: SOLDERING AREA (CONTACT TINE, PEG) TIN PL.: SOLDERING AREA (TAB) Ni UNDER PL.: 0.002mm MIN. ALL OVER	240	1-2134250-1
	WHITE	BLACK	Au PL.: 0.00038mm MIN. (CONTACT AREA) Au FLASH PL.: SOLDERING AREA (CONTACT TINE, PEG) TIN PL.: SOLDERING AREA (TAB) Ni UNDER PL.: 0.002mm MIN. ALL OVER	240	1-2134250-1
	EXTRACTOR COLOR	HOUSING COLOR	△ FINISH	POS	PART NO.
THIS DRAWING IS A CONTROLLED DOCUMENT.			DWN T.FUMIKURA 01APR2011	TE Connectivity	
			CHK E.TAKEMASA 01APR2011		
DIMENSIONS: 單位: 耗 MM			APVD E.TAKEMASA 01APR2011	NAME 名称	
TOLERANCES UNLESS OTHERWISE SPECIFIED: 一般公差			PRODUCT SPEC 製品規格 108-78570	DDR3 DIMM SOCKET 1mm PITCH SMT 240 POS. VERY LOW PROFILE TYPE	
			APPLICATION SPEC 取付適用規格	SIZE	CAGE CODE
MATERIAL 材料			WEIGHT 5.3 g	DRAWING NO 番号	RESTRICTED TO
SEE NOTES			CUSTOMER DRAWING	SCALE 尺度 2:1	SHEET 1 OF 6
SEE NOTES				REV F2	

4

3

2

1

THIS DRAWING IS UNPUBLISHED. RELEASED FOR PUBLICATION
 © COPYRIGHT - By - ALL RIGHTS RESERVED.

LOC	DIST	REVISIONS		
J		P	LTR	DESCRIPTION
		-		SEE SHEET 1
				DATE
				DWN
				APVD

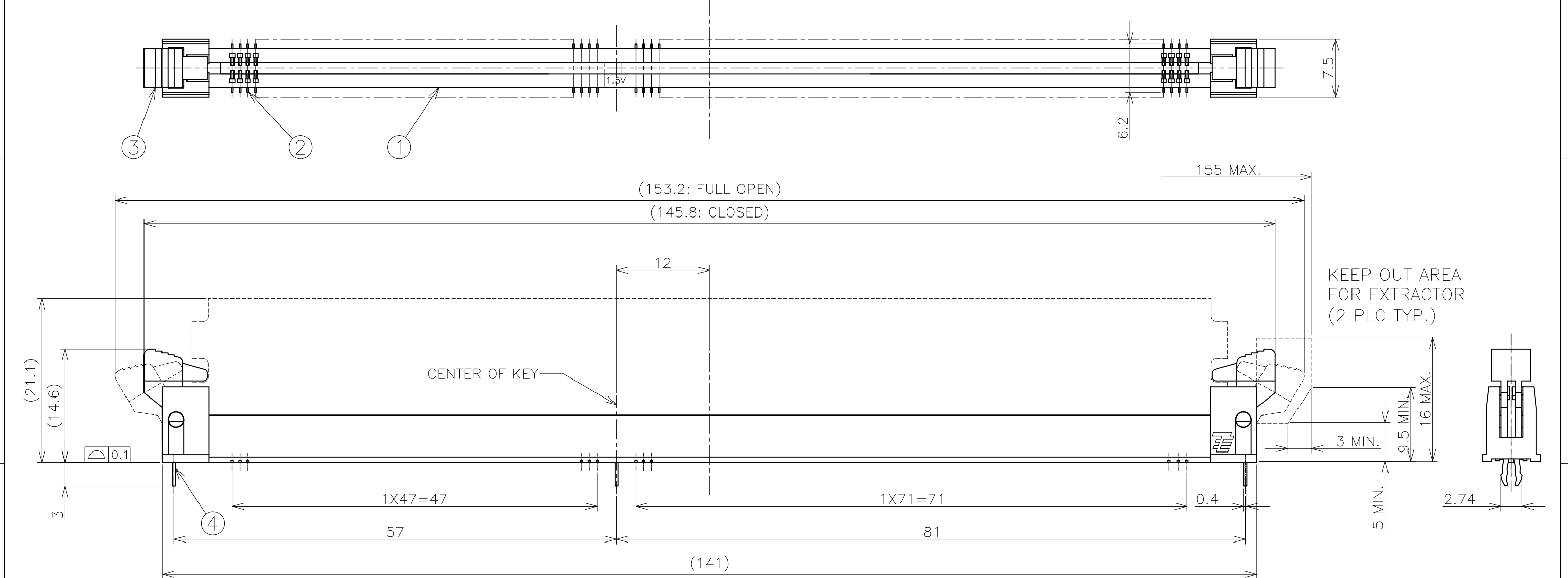

3	LEG	4
2	EXTRACTOR	3
240	CONTACT	2
1	HOUSING	1
QTY	ITEM	ITEM NO.

(F2) — Δ	N/A	BLACK	BLACK	Au PL.: 0.00076mm MIN. (CONTACT AREA)	240	6-2134250-4
(F2) — Δ		WHITE	BLACK	Au FLASH PL.: SOLDERING AREA	240	6-2134250-3
				Ni UNDER PL.: 0.002mm MIN. ALL OVER		
	CAP COLOR	EXTRACTOR COLOR	HOUSING COLOR	FINISH	POS	PART NO.

GENERAL TOERLANCE

10 ≥	±0.2
30 ≥	>10 ; ±0.3
100 ≥	>30 ; ±0.5
ANGLE ; ±3°	

THIS DRAWING IS A CONTROLLED DOCUMENT.

DIMENSIONS: 單位: 耗 MM	TOLERANCES UNLESS OTHERWISE SPECIFIED: 一般公差
	0 PLC ± -
	1 PLC ± -
	2 PLC ± -
	3 PLC ± -
	4 PLC ± -
	ANGLES ± 3°
MATERIAL 材料	FINISH 仕上
SEE NOTES	SEE NOTES

DWN	01APR2011	TE Connectivity
CHK	01APR2011	
APVD	01APR2011	
PRODUCT SPEC 製品規格		NAME 名称 DDR3 DIMM SOCKET 1mm PITCH SMT 240 POS. VERY LOW PROFILE TYPE
APPLICATION SPEC 取付適用規格		
SIZE	A3	RESTRICTED TO
CAGE CODE	00779	
DRAWING NO	C-2134250	
WEIGHT		
CUSTOMER DRAWING		SCALE 尺度 2:1
		SHEET 2 of 6
		REV F2

THIS DRAWING IS UNPUBLISHED.

RELEASED FOR PUBLICATION

© COPYRIGHT - By -

ALL RIGHTS RESERVED.

LOC	DIST	REVISIONS			DATE	DWN	APVD
J		P	LTR	DESCRIPTION			
		-		SEE SHEET 1	-	-	-

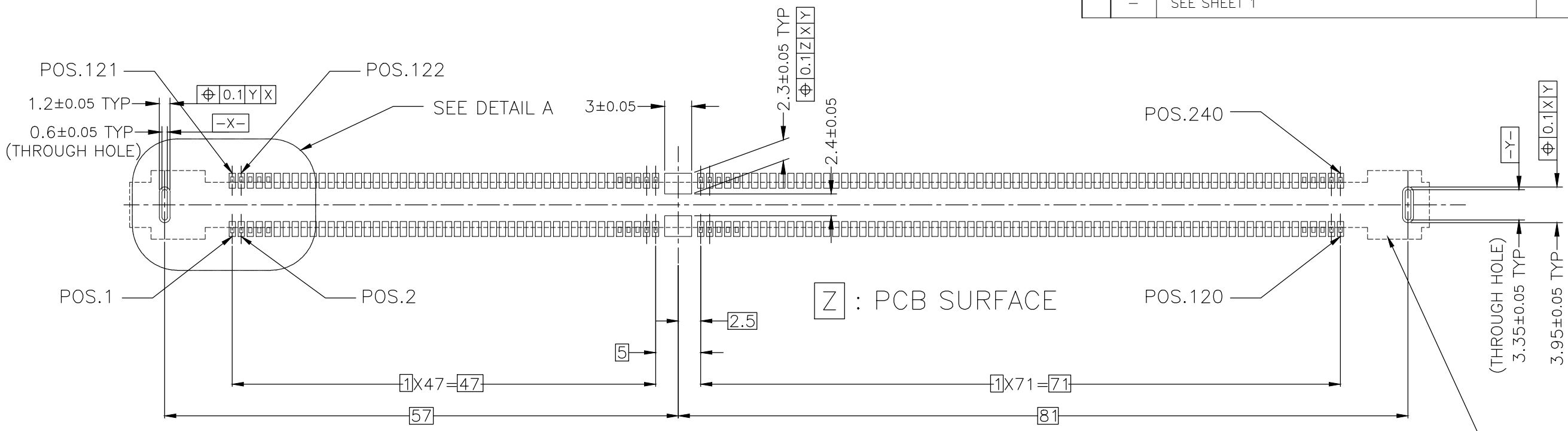

REFERENCE PCB LAYOUT (VIEWED FROM CONNECTOR SIDE)

CONNECTOR OUTLINE

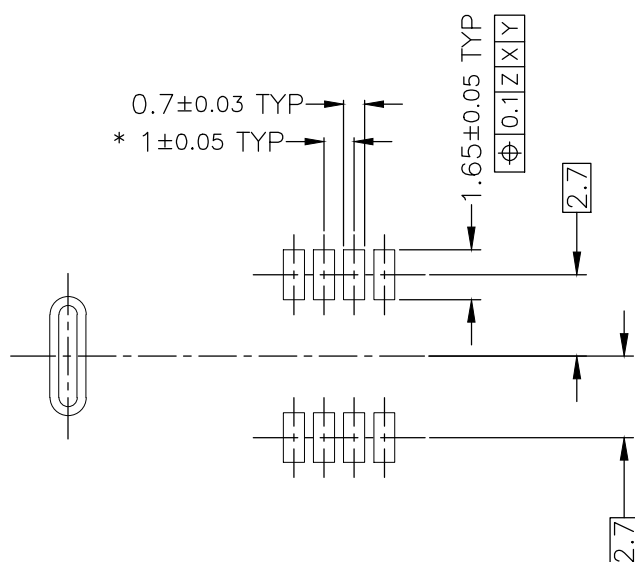

DETAIL A (4:1)

* : TOLERANCE; NON-CUMULATIVE

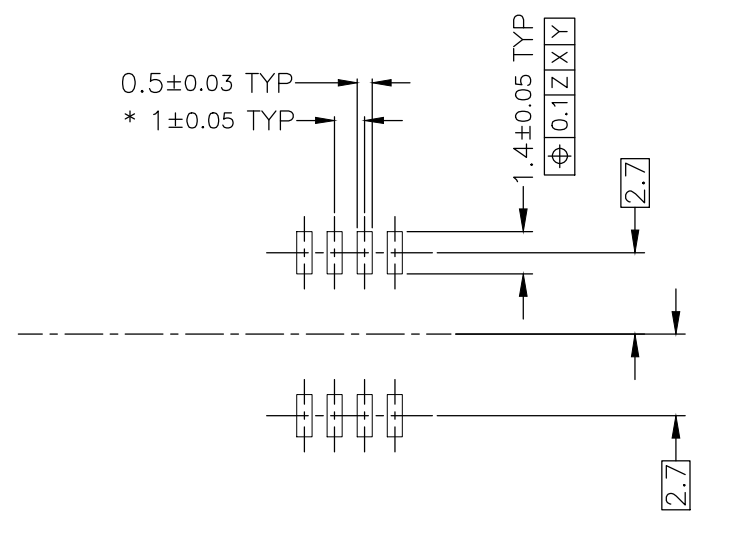

REFERENTIAL METAL MASK PAD OPENING (4:1)

* : TOLERANCE; NON-CUMULATIVE

THIS PCB LAYOUT IS FOR 1-2134250-1~1-2134250-6,3-2134250-1~3-2134250-2.
 RECOMMENDED PC BOARD X/Y CTE. 10-14 [ppm/DEGREE CELSIUS]
 PLEASE VERIFY CTE MATCHING BEFORE USING THE SOCKETS.
 FOR ANY INQUIRY. PLEASE CONTACT TE Connectivity.

THIS DRAWING IS A CONTROLLED DOCUMENT.

DIMENSIONS: 単位: 耗 MM	TOLERANCES UNLESS OTHERWISE SPECIFIED: 一般公差
	0 PLC ± - 1 PLC ± - 2 PLC ± - 3 PLC ± - 4 PLC ± - ANGLES ± 3'
MATERIAL 材料	FINISH 仕上
SEE NOTES	SEE NOTES

GENERAL TOERLANCE	
10 ≥	±0.2
30 ≥	>10 ; ±0.3
100 ≥	>30 ; ±0.5
ANGLE ; ±3'	

DWN	TE Connectivity		
CHK	NAME 名称		
APVD	DDR3 DIMM SOCKET 1mm PITCH SMT 240 POS. VERY LOW PROFILE TYPE		
PRODUCT SPEC 製品規格	SIZE	CAGE CODE	DRAWING NO 番号
APPLICATION SPEC 取付適用規格	A3	00779	G-2134250
WEIGHT	CUSTOMER DRAWING		RESTRICTED TO
SCALE 尺度	2:1	SHEET 3 of 6	REV F2

THIS DRAWING IS UNPUBLISHED. RELEASED FOR PUBLICATION
 © COPYRIGHT - By - ALL RIGHTS RESERVED.

LOC	DIST	REVISIONS		
J		P	LTR	DESCRIPTION
				DATE
				DWN
				APVD
		SEE SHEET 1		

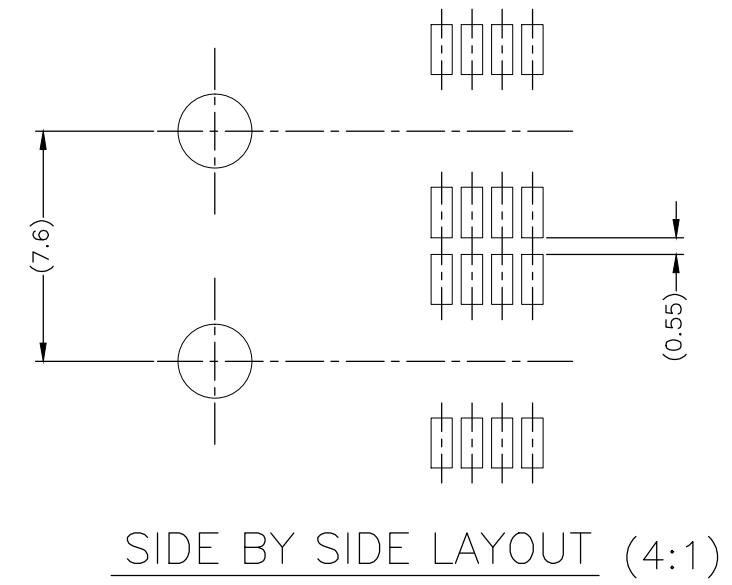
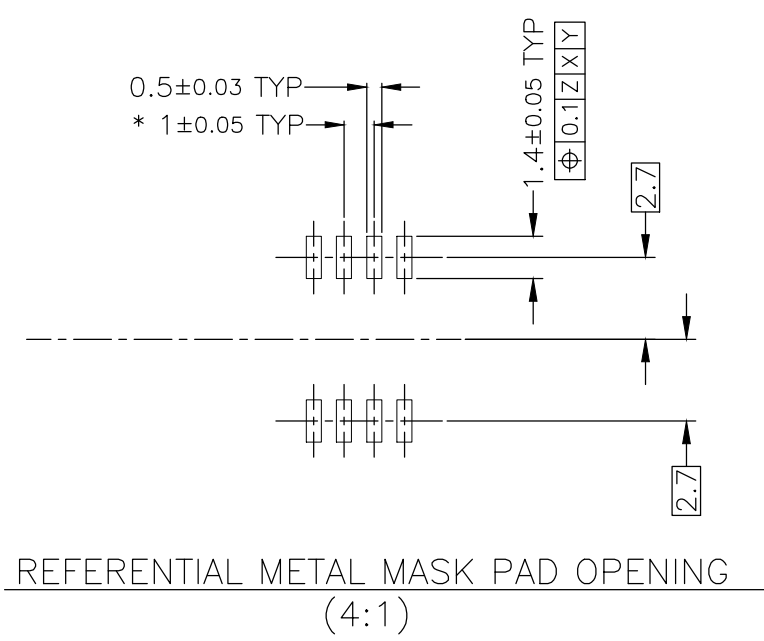
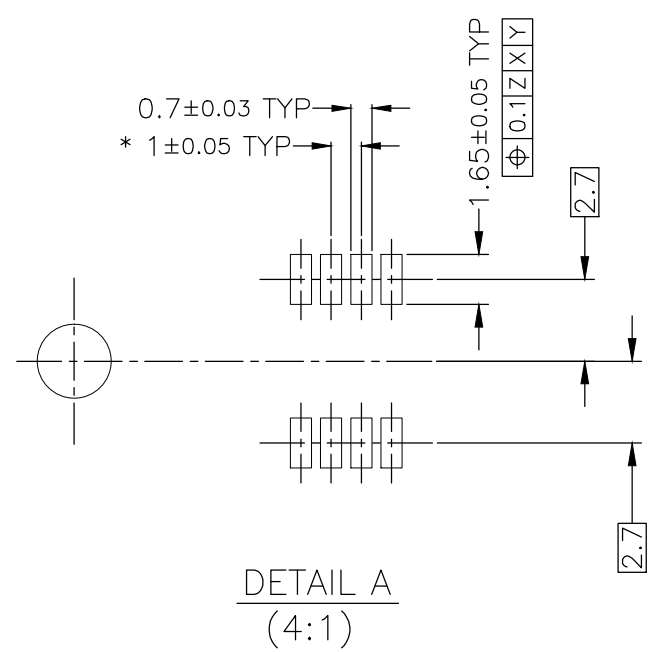
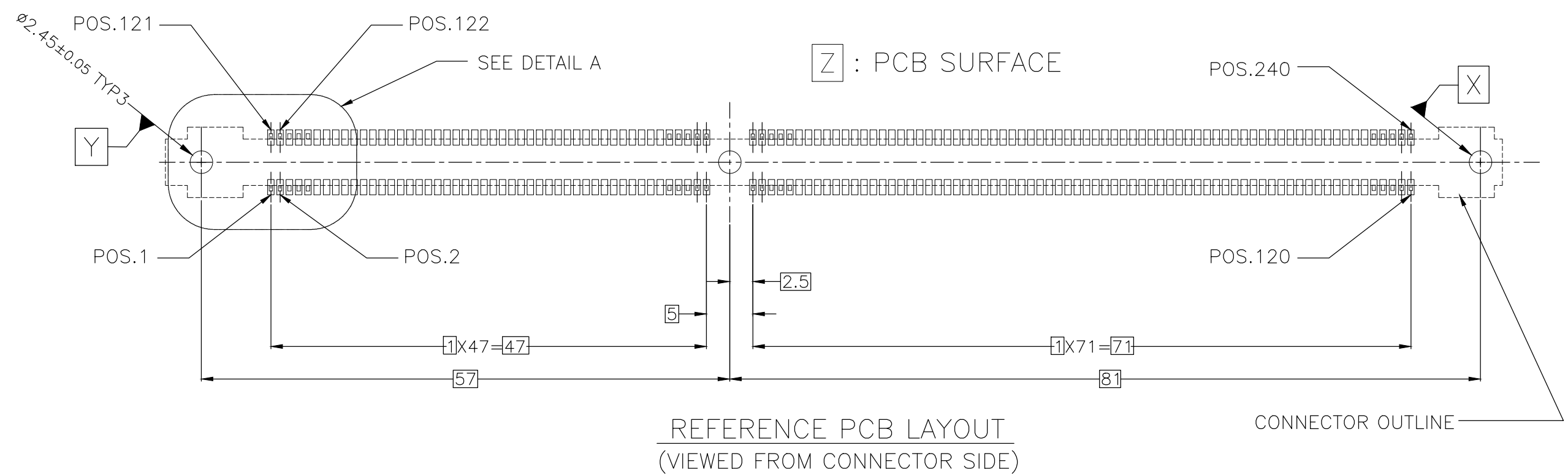

* : TOLERANCE; NON-CUMULATIVE

* : TOLERANCE; NON-CUMULATIVE

THIS PCB LAYOUT IS FOR 6-2134250-3~6-2134250-4.
 RECOMMENDED PC BOARD X/Y CTE. 10-14 [ppm/DEGREE CELSIUS]
 PLEASE VERIFY CTE MATCHING BEFORE USING THE SOCKETS.
 FOR ANY INQUIRY. PLEASE CONTACT TE Connectivity.

GENERAL TOLERANCE	
10 ≥	±0.2
30 ≥	>10 ; ±0.3
100 ≥	>30 ; ±0.5
ANGLE ; ±3°	

THIS DRAWING IS A CONTROLLED DOCUMENT.	
DIMENSIONS: 单位: 耗 MM	TOLERANCES UNLESS OTHERWISE SPECIFIED: 一般公差
	0 PLC ± -
	1 PLC ± -
	2 PLC ± -
	3 PLC ± -
	4 PLC ± -
	ANGLES ± 3°
MATERIAL 材料	FINISH 仕上
SEE NOTES	SEE NOTES

DWN	STE TE Connectivity		
CHK	NAME 名称		
APVD	DDR3 DIMM SOCKET 1mm PITCH SMT 240 POS. VERY LOW PROFILE TYPE		
PRODUCT SPEC 製品規格	SIZE	CAGE CODE	DRAWING NO 番号
APPLICATION SPEC 取付適用規格	A3	00779	G-2134250
WEIGHT	CUSTOMER DRAWING		RESTRICTED TO
	SCALE 尺度	SHEET	REV
	2:1	4 OF 6	F2

THIS DRAWING IS UNPUBLISHED. RELEASED FOR PUBLICATION
 © COPYRIGHT - By - ALL RIGHTS RESERVED.

LOC	DIST	REVISIONS					
		P	LTR	DESCRIPTION	DATE	DWN	APVD
J		-		SEE SHEET 1	-	-	-

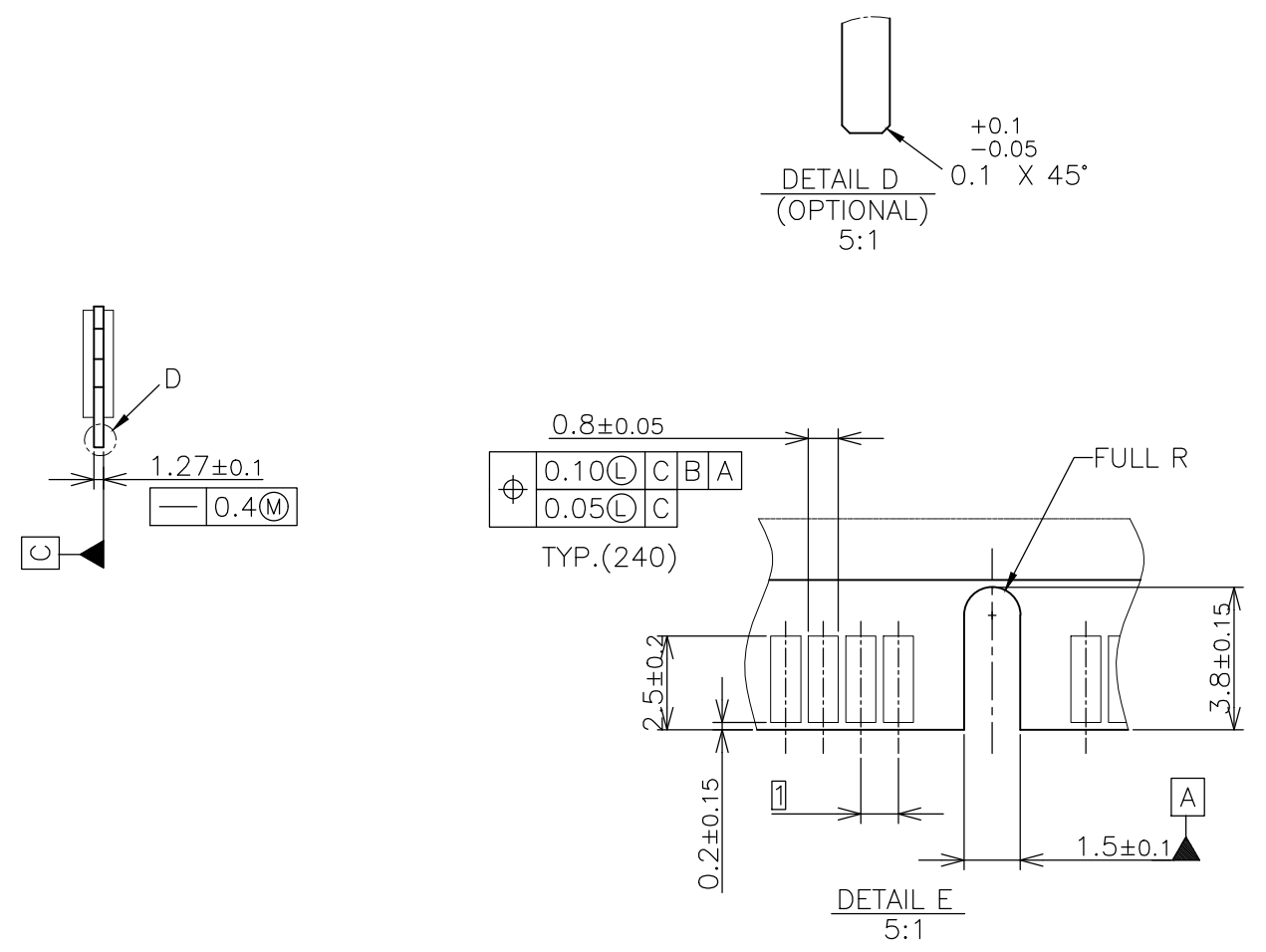
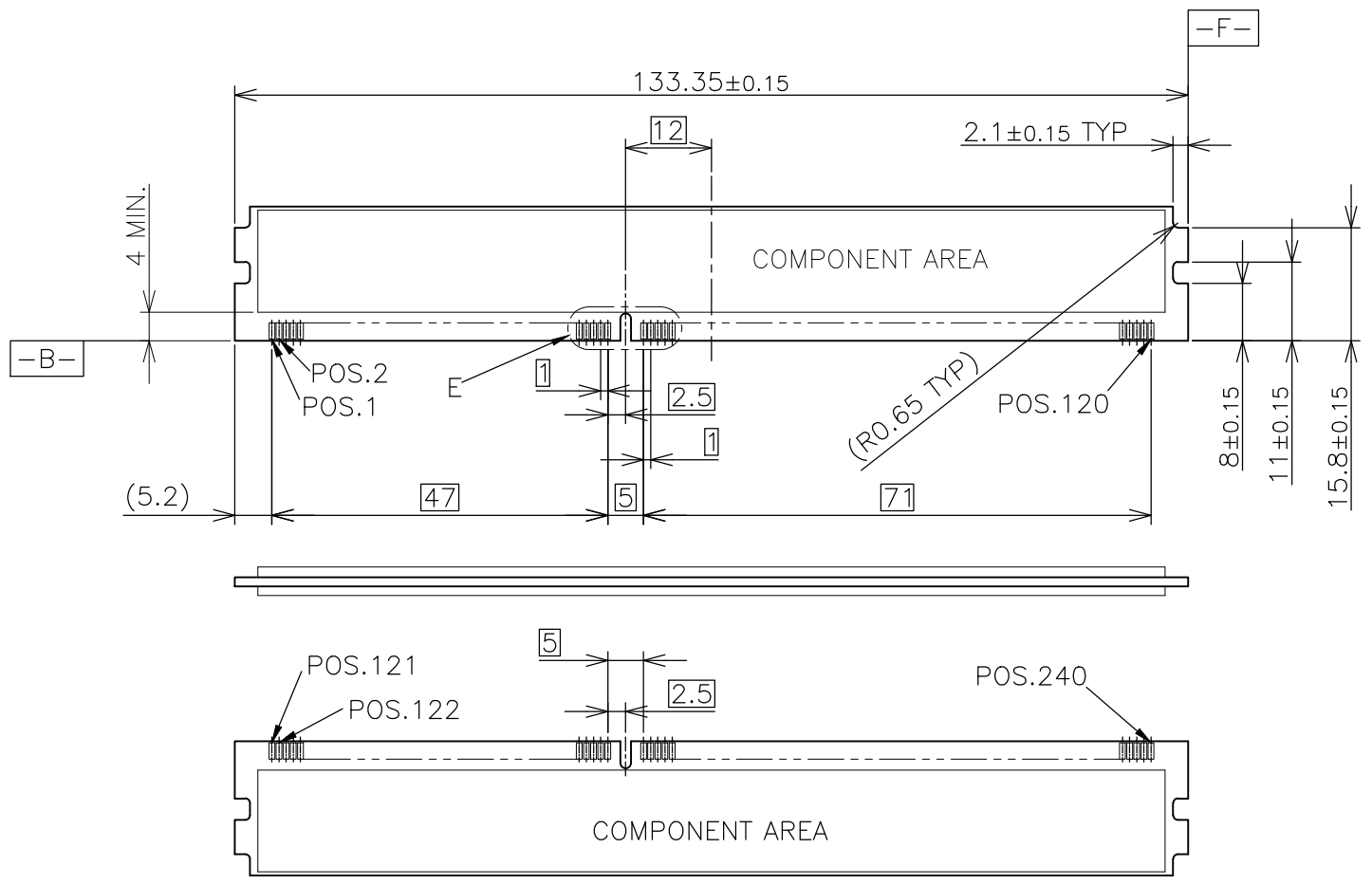

REFERENCE DIMM PCB LAYOUT

RECOMMENDED PLATING FOR CONTACT PADS ARE:

- 1) PREFERABLE PLATING : ELECTROLYTIC GOLD PLATING 0.00076 mm MIN. OVER ELECTROLYTIC NICKEL 0.002 mm MIN.
- 2) ALTERNATIVE PLATING : GOLD PLATING 0.00005-0.00075 mm OVER NICKEL 0.002 mm MIN. MUST USE AN ELECTRONIC CONTACT GRADE CORROSIVE BARRIER LUBRICANT.

GENERAL TOLERANCE

10 ≥	±0.2
30 ≥	>10 ; ±0.3
100 ≥	>30 ; ±0.5
ANGLE ; ±3°	

THIS DRAWING IS A CONTROLLED DOCUMENT.		DWN		TE Connectivity	
DIMENSIONS: 单位: 耗 MM		CHK			
TOLERANCES UNLESS OTHERWISE SPECIFIED: 一般公差		APVD		NAME 名称	
0 PLC ± - 1 PLC ± - 2 PLC ± - 3 PLC ± - 4 PLC ± - ANGLES ± 3°		PRODUCT SPEC 製品規格		DDR3 DIMM SOCKET 1mm PITCH SMT 240 POS. VERY LOW PROFILE TYPE	
MATERIAL 材料 SEE NOTES		FINISH 仕上 SEE NOTES		DRAWING NO 番号	
		WEIGHT		A3 00779 C-2134250	
		CUSTOMER DRAWING		RESTRICTED TO	
		SCALE 尺度 1:1		SHEET 5 OF 6	
				REV F2	

THIS DRAWING IS UNPUBLISHED. RELEASED FOR PUBLICATION
 © COPYRIGHT - By - ALL RIGHTS RESERVED.

LOC	DIST	REVISIONS		
J		P	LTR	DESCRIPTION
		-		SEE SHEET 1
			DATE	DWN
			-	-
				APVD
				-

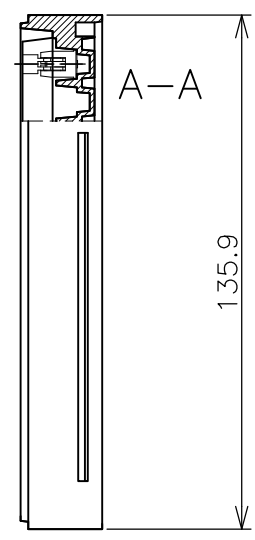
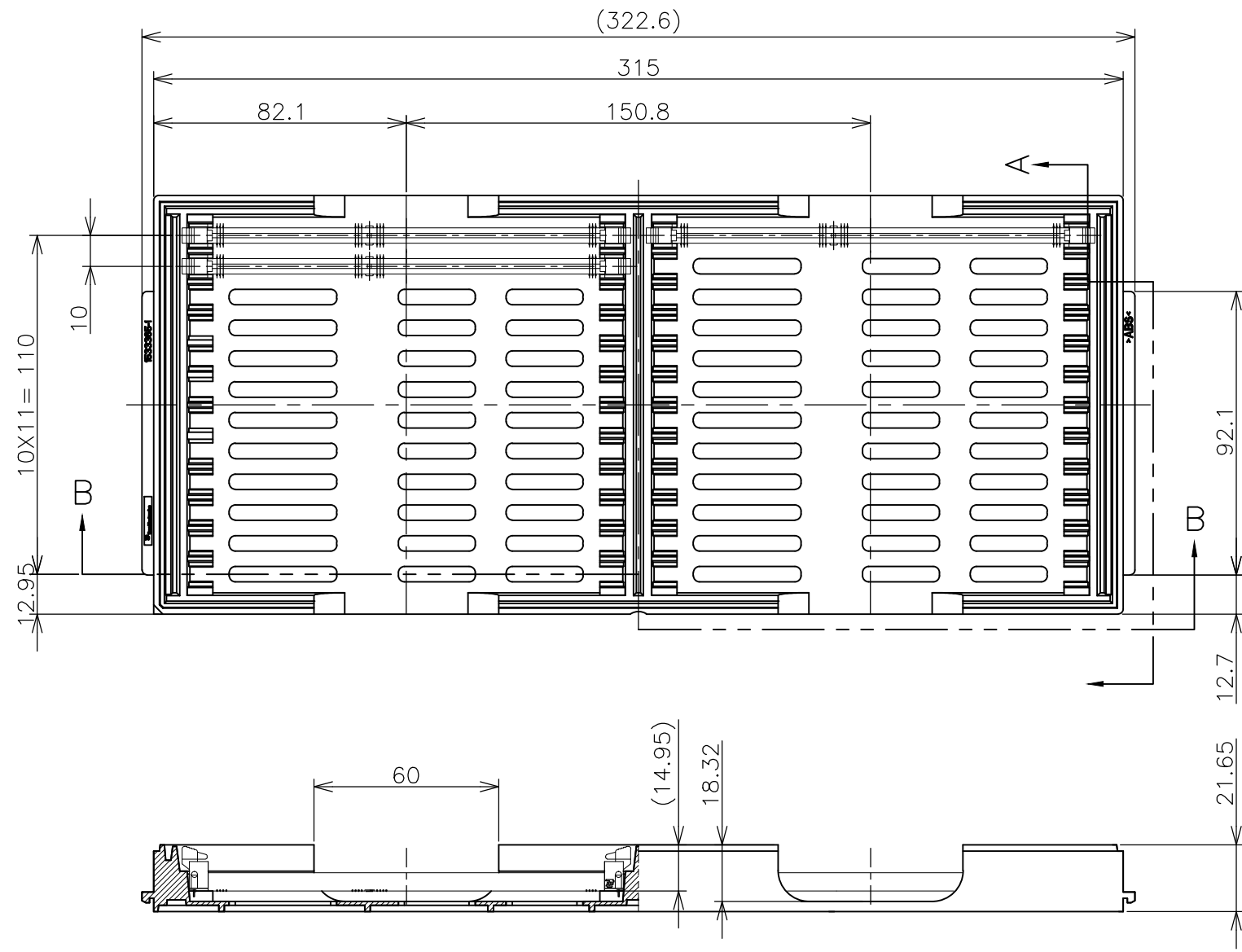

QTY: 24EA/TRAY

THIS DRAWING IS A CONTROLLED DOCUMENT.

DIMENSIONS: 单位: 耗 MM	TOLERANCES UNLESS OTHERWISE SPECIFIED: 一般公差
0 PLC ± -	1 PLC ± -
2 PLC ± -	3 PLC ± -
4 PLC ± -	ANGLES ± 3°

GENERAL TOERLANCE
10 ≥ ; ±0.2
30 ≥ >10 ; ±0.3
100 ≥ >30 ; ±0.5
ANGLE ; ±3°

MATERIAL 材料	FINISH 仕上
SEE NOTES	SEE NOTES

DWN
CHK
APVD
PRODUCT SPEC 製品規格
APPLICATION SPEC 取付適用規格
WEIGHT

STE TE Connectivity

NAME
名称
DDR3 DIMM SOCKET 1mm PITCH SMT
240 POS. VERY LOW PROFILE TYPE

SIZE	CAGE CODE	DRAWING NO 番号	RESTRICTED TO
A3	00779	G-2135250	

CUSTOMER DRAWING

SCALE 尺度	SHEET	REV
1:2	6 OF 6	F2