



Chipsmall Limited consists of a professional team with an average of over 10 year of expertise in the distribution of electronic components. Based in Hongkong, we have already established firm and mutual-benefit business relationships with customers from,Europe,America and south Asia,supplying obsolete and hard-to-find components to meet their specific needs.

With the principle of “Quality Parts,Customers Priority,Honest Operation,and Considerate Service”,our business mainly focus on the distribution of electronic components. Line cards we deal with include Microchip,ALPS,ROHM,Xilinx,Pulse,ON,Everlight and Freescale. Main products comprise IC,Modules,Potentiometer,IC Socket,Relay,Connector.Our parts cover such applications as commercial,industrial, and automotives areas.

We are looking forward to setting up business relationship with you and hope to provide you with the best service and solution. Let us make a better world for our industry!



## Contact us

Tel: +86-755-8981 8866 Fax: +86-755-8427 6832

Email & Skype: info@chipsmall.com Web: www.chipsmall.com

Address: A1208, Overseas Decoration Building, #122 Zhenhua RD., Futian, Shenzhen, China



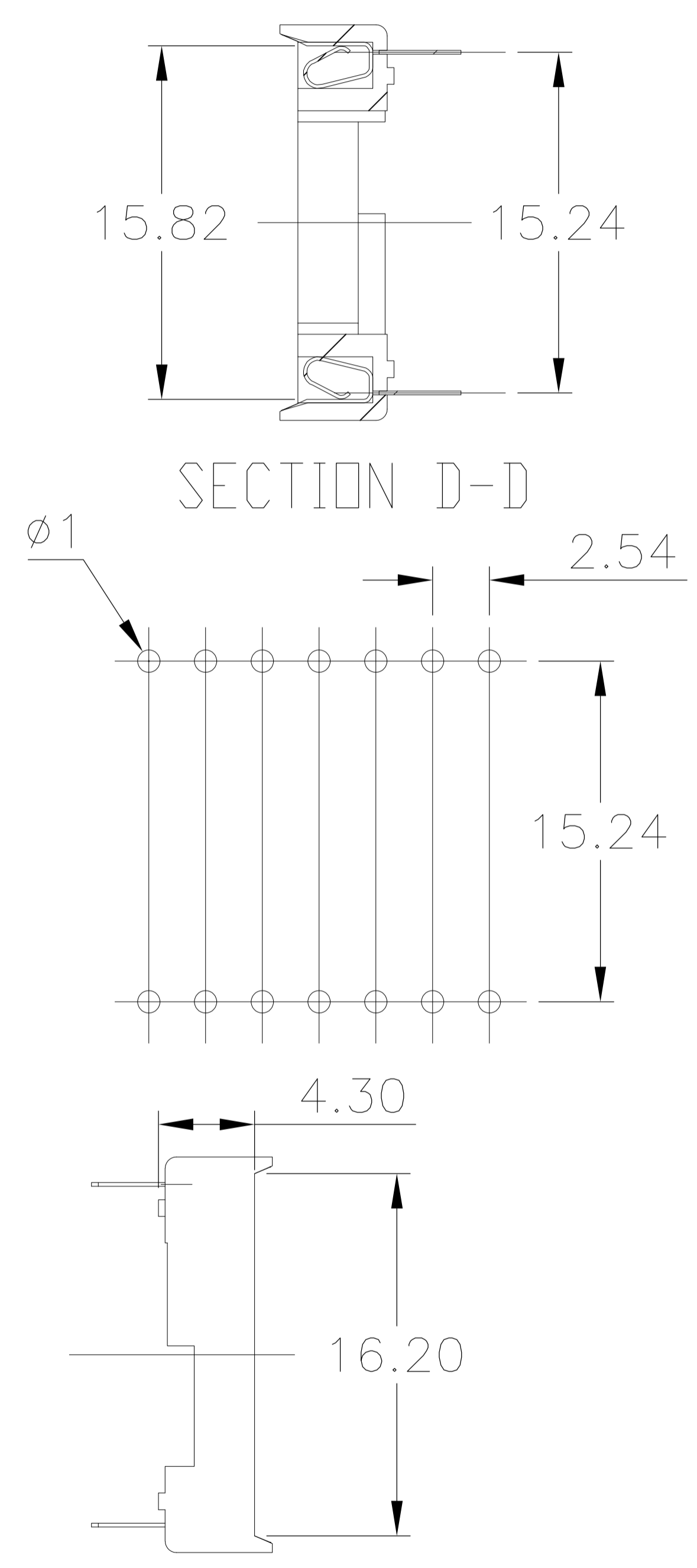
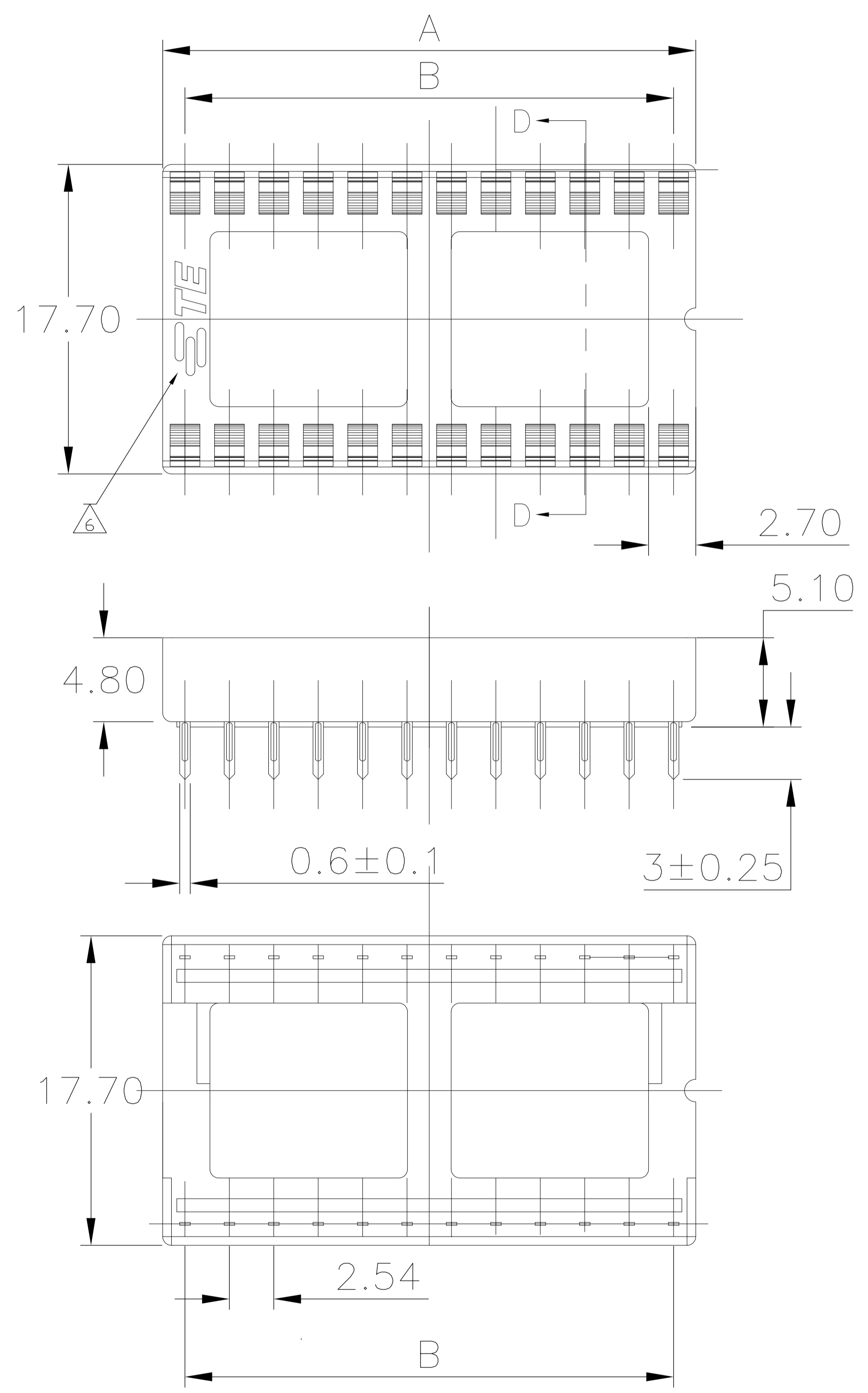

- NOTE:
- 1 MATERIAL:  
HOUSING: 30% GLASS FILLED PBT, THERMOPLASTIC, BLACK.  
CONTACT: PHOS BRONZE
  - 2 FINISH: CONTACT PLATING TIN (LEAD FREE); 60 UIN MIN. OVER 30 UIN NI  
SOLDERABILITY :95% COVERAGE MIN.;  
WORKING CONDITION:230°±5°C;
  3. MECHANICAL SPECS:  
DURABILITY: 50 CYCLES MIN.  
INSERTION FORCE:300 GRAMS MAX.  
WITHDRAWAL FORCE: 20 GRAMS MIN.  
CONTACT RETENTION: 500 GRAMS MIN.  
ACCEPTS: 0.20-0.30 [.008-.012] LEADS
  4. ELECTRICAL SPECS:  
VOLTAGE RATING: 250V AC,DC  
CONTACT RESISTANCE: 20 MILLOHMS MAX.  
CURRENT RATING: 1 AMPERE AC,DC  
INSULATION RESISTANCE: 1000 MEGOHMS MIN.  
DIELECTRIC WITHSTANDING VOLTAGE: AC 1000 V MIN.
  5. OPERATING TEMPERATURE: -40°C TO +105°C
  - 6 TE LOGO

△2	40	50.80	48.26	1-2199299-5
△2	28	35.56	33.02	1-2199299-2
FINISH	POS	A±0.20	B±0.15	PART NO.

THIS DRAWING IS A CONTROLLED DOCUMENT.		DIN WINNG WANG 18NOV2013	TE Connectivity
DIMENSIONS: mm		CHK SIMON LI 18NOV2013	
TOLERANCES UNLESS OTHERWISE SPECIFIED:		APVD COREL WANG 18NOV2013	NAME
0 PLG ±	1 PLG ±	PRODUCT SPEC	DIP SOCKET, .600 CENTER LINE LADDER STYLE
2 PLG ± 0.2[.008]	3 PLG ±	APPLICATION SPEC	
4 PLG ±	ANGLES ±	SIZE CAGE CODE DRAWING NO	RESTRICTED TO
MATERIAL △1	FINISH △2-7	WEIGHT A1 - C=2199299	
CUSTOMER DRAWING		SCALE 5:1	SHEET 1 OF 1 REV A