



Chipsmall Limited consists of a professional team with an average of over 10 year of expertise in the distribution of electronic components. Based in Hongkong, we have already established firm and mutual-benefit business relationships with customers from,Europe,America and south Asia,supplying obsolete and hard-to-find components to meet their specific needs.

With the principle of “Quality Parts,Customers Priority,Honest Operation,and Considerate Service”,our business mainly focus on the distribution of electronic components. Line cards we deal with include Microchip,ALPS,ROHM,Xilinx,Pulse,ON,Everlight and Freescale. Main products comprise IC,Modules,Potentiometer,IC Socket,Relay,Connector.Our parts cover such applications as commercial,industrial, and automotives areas.

We are looking forward to setting up business relationship with you and hope to provide you with the best service and solution. Let us make a better world for our industry!



Contact us

Tel: +86-755-8981 8866 Fax: +86-755-8427 6832

Email & Skype: info@chipsmall.com Web: www.chipsmall.com

Address: A1208, Overseas Decoration Building, #122 Zhenhua RD., Futian, Shenzhen, China



THIS DRAWING IS UNPUBLISHED.		RELEASED FOR PUBLICATION	
© COPYRIGHT - By -		ALL RIGHTS RESERVED.	
PROJECT	PRJ-16-000909157		
PART NO.	X-2308327-X		
DESCRIPTION	FULL METAL HOODS SIZE 3		
CUSTOMER	GENERAL MARKET		

REVISIONS					
P	LTR	DESCRIPTION	DATE	DWN	APVD
	A2	REVISED PER ECR-16-014891	20OCT2016	KK	GG

NOTES:

1. TEMPERATURE: -40°C TO +90°C.
2. STRAND DIAMETER OF CRIMP FLANGE: 2.7-8.7 mm.
3. CABLE DIAMETER WITH EXTERNAL CABLE CLAMP: 4-14 mm.
4. CABLE DIAMETER WITH INTERNAL CABLE CLAMP: d=4-11 mm (FOR d=4-7 mm TURN CABLE CLAMP).
5. CABLE BUSHING FOR CABLE DIAMETER 4-9 mm.

* CRIMP FLANGE PN *-2308349-* TO BE ORDERED SEPARATELY.

* CRIMP BARREL TO BE USED IN COMBINATION WITH THE FLANGE PN *-2308350-* TO BE ORDERED SEPARATELY.

* CABLE CLAMP SCREW VERSION PN *-2308272-* TO BE ORDERED SEPARATELY.

1-2308327-5	FULL METAL HOOD3 5	HOUSING 2	1	2	2	3	61
1-2308327-4	FULL METAL HOOD3 4	HOUSING 2	2	1	1	2	63
1-2308327-3	FULL METAL HOOD3 3	HOUSING 2	1	2	-	3	59
1-2308327-2	FULL METAL HOOD3 2	HOUSING 2	2	1	-	2	61
1-2308327-1	FULL METAL HOOD3 1	HOUSING 1	2	-	-	-	57
ASSY. PART NO.	DESCRIPTION	SUB-PART DESCRIPTION POS.1	POS. 3	POS. 5	POS. 6	POS. 7	WEIGHT, g

9	1	-	SCREW M2.5x5 (CASE HARDENING STEEL, ZINC-PLATED)
8	4	-	SCREW M2.5x6.5 (CASE HARDENING STEEL, ZINC-PLATED)
7	SEE TAB. POS.7	-	SCREW M2.5x6 (CASE HARDENING STEEL, ZINC-PLATED)
6	SEE TAB. POS.6	-	CABLE BUSHING (EPTR SANTOPRENE)
5	SEE TAB. POS.5	-	CABLE CLAMP (BAND STEEL, ZINC-PLATED)
4	2	-	CATCH SPRING (STAINLESS STEEL, RAW)
3	SEE TAB. POS.3	-	BLIND PLATE (ZINC ALLOY, RAW)
2	1	-	COVER (ZINC ALLOY, RAW)
1	1	SEE TAB. POS.1	HOUSING (ZINC ALLOY, RAW)
SL NO.	QTY	ASSY. PART NO.	DESCRIPTION (MATERIAL, FINISH)

X-2308327-X

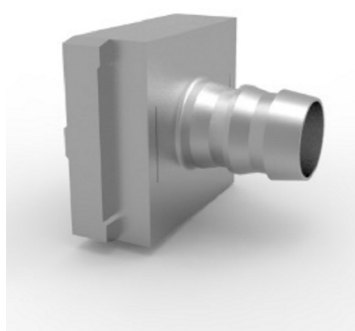
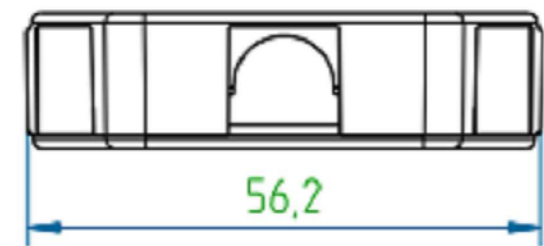
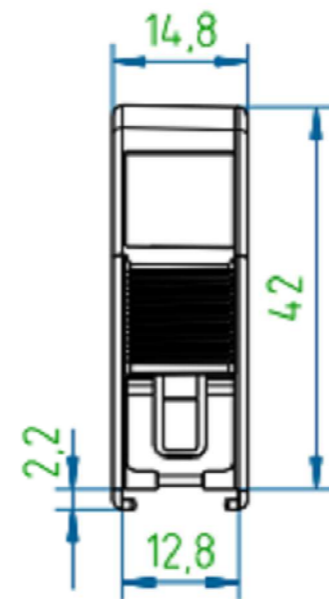
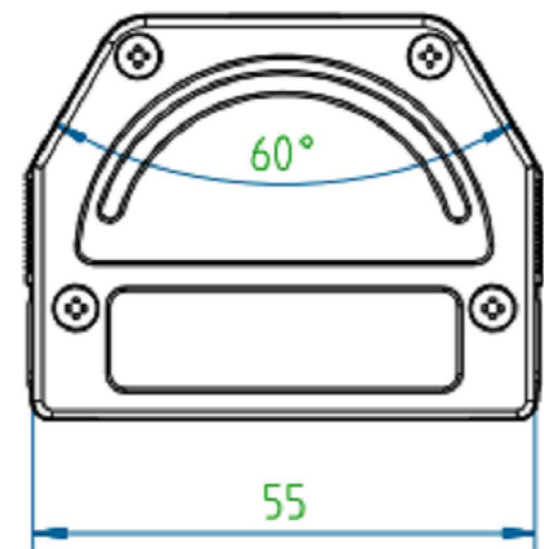
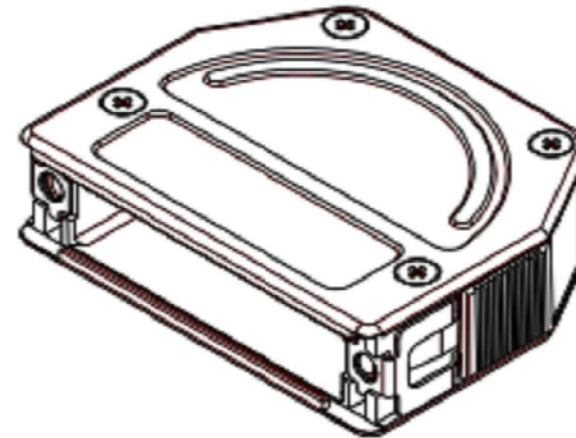
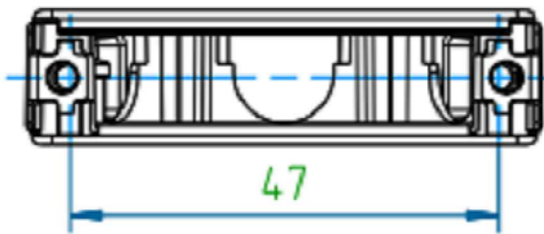

CRIMP FLANGE

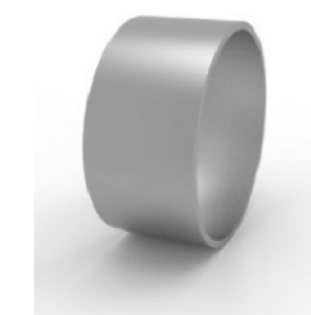

CRIMP BARREL



CABLE CLAMP

HOUSING 1

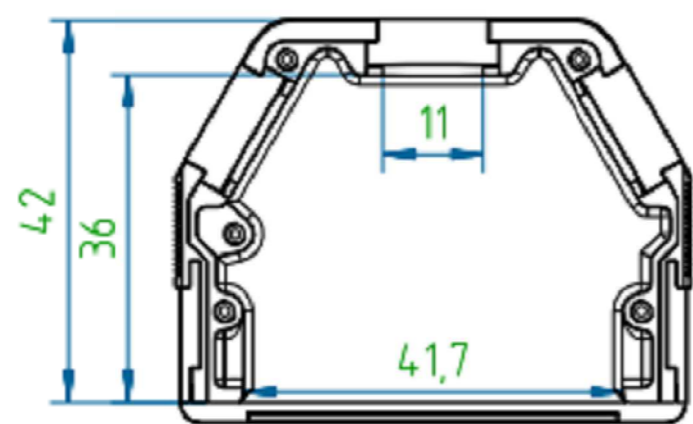

HOUSING 2

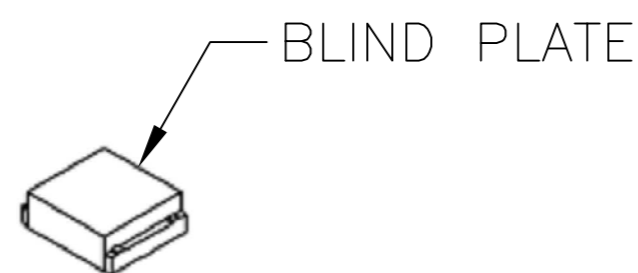
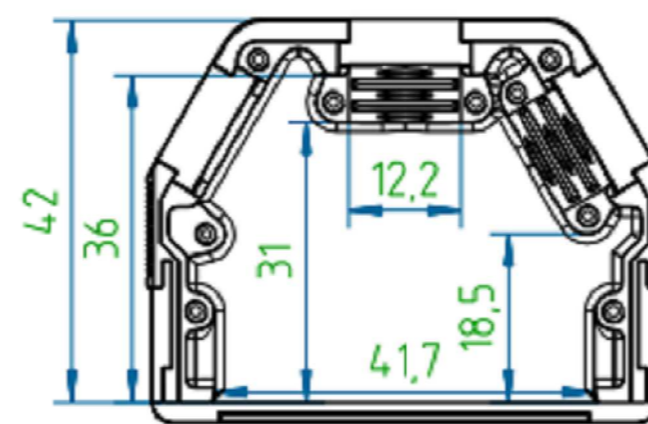

BLIND PLATE

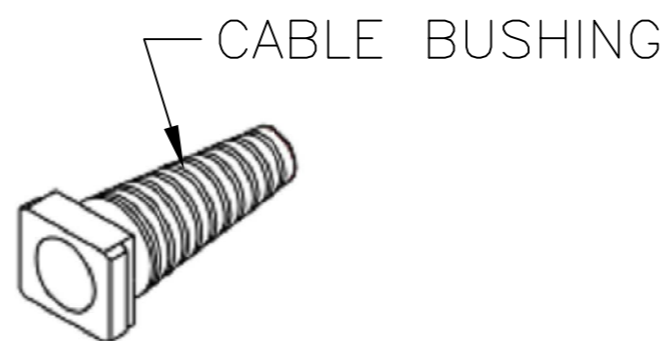

CABLE BUSHING

THIS DRAWING IS A CONTROLLED DOCUMENT.		DWN KIRAN K 02AUG2016		
DIMENSIONS: mm		CHK GUNASEKHAR G 02AUG2016		
TOLERANCES UNLESS OTHERWISE SPECIFIED: DIN ISO 2768 m		APVD GUNASEKHAR G 02AUG2016	NAME FULL METAL HOODS SIZE 3	
0 PLC ± -		PRODUCT SPEC	APPLICATION SPEC	
1 PLC ± -		WEIGHT		
2 PLC ± -		SCALE NTS		
3 PLC ± -		SHEET 1 of 1		
4 PLC ± -		REV A2		
ANGLES ± -		CUSTOMER DRAWING		
FINISH		SIZE A2 CAGE CODE 00779 DRAWING NO. G=2308327 RESTRICTED TO -		