



Chipsmall Limited consists of a professional team with an average of over 10 year of expertise in the distribution of electronic components. Based in Hongkong, we have already established firm and mutual-benefit business relationships with customers from,Europe,America and south Asia,supplying obsolete and hard-to-find components to meet their specific needs.

With the principle of “Quality Parts,Customers Priority,Honest Operation,and Considerate Service”,our business mainly focus on the distribution of electronic components. Line cards we deal with include Microchip,ALPS,ROHM,Xilinx,Pulse,ON,Everlight and Freescale. Main products comprise IC,Modules,Potentiometer,IC Socket,Relay,Connector.Our parts cover such applications as commercial,industrial, and automotives areas.

We are looking forward to setting up business relationship with you and hope to provide you with the best service and solution. Let us make a better world for our industry!



Contact us

Tel: +86-755-8981 8866 Fax: +86-755-8427 6832

Email & Skype: info@chipsmall.com Web: www.chipsmall.com

Address: A1208, Overseas Decoration Building, #122 Zhenhua RD., Futian, Shenzhen, China



RAFIX 22 FS⁺

Control components of the future

The RAFIX 22 FS⁺ series is setting new standards in the world of control components. Extremely flat construction and functional aesthetic design are essential in an increasingly design-oriented industrial environment. The wide variety and variability of the actuators give your designer complete freedom: round or square collar types, radiant colours and homogenous illumination of the large actuat-

ing areas are among the basic features. Combined with the various front rings, they ensure that you can create a panel with a truly distinctive design. For example, a defined colour can be consistently assigned to a specific command. In addition, the large number of colour options available for the front rings enables easy customisation to suit the corporate design of different OEMs.



2

RAFIX
22 FS⁺

Fast

The fastest connection type for every application: with a printed circuit board or directly with quick-connect terminals.

- A printed circuit board is the best and fastest solution, starting with medium quantities. Moreover, PCB contact blocks can be ideally combined with displays, tactile switches and other electronics on a common printed circuit board.
- Alternatively, QC contact blocks can be easily snapped into the actuators without tools. Male quick-connect terminals are used directly for wiring in a conventional manner. This is a fast and efficient variant for applications where a printed circuit board is not cost-effective.

+ PLUS

RAFIX 22 FS⁺ has additional benefits for you:

- Various actuators and contact block options – a complete series
- Variable thanks to round or square operating elements
- Variable thanks to gold contacts from 5 V or silver contacts up to 250 V
- Short-travel adapter for short-travel actuation (1 mm switching travel) with perceptible key click
- Variable design thanks to various front ring colours
- Variable illumination, compatible with 3 mm THT LEDs or SMT LEDs

SLIM

Now it's a snap to slim the design of your control systems thanks to the low mounting depth.

- Designs with PCB contact blocks feature a distance between the front panel and printed circuit board of only 9.2 mm; the same applies to contact blocks with silver contacts for the mains voltage. That's as slim as it gets.
- Also when fitted with QC contact blocks, RAFIX 22 FS⁺ panels are unbeatably flat. Requiring only 27 mm of space behind the front panel, they provide tremendous design scope for inspiring control panels.



CONTROL COMPONENTS

RAFIX 22 FS⁺ CONTROL COMPONENTS

RAFIX 22 FS⁺

The RAFIX 22 FS⁺ series has a variety of actuators with round or square collar types:



Pushbuttons

- Illuminable
- With flush or protruding lens
- With flush or protruding front ring
- With protective cap
- With exchangeable FLEXLAB lens
- With illuminated front ring (optional)

Selector switches

- Rotating angle 40°, 60° or 90°
- Latching or momentary
- Illuminable

Keylock switches

- Rotating angle 40° or 90°
- Latching or momentary

Signal indicators

- Green, yellow, red, blue or white

Approvals

- IEC 60947-5-1/5
- UL
- CCC

Safe and reliable

The actuators in the RAFIX 22 FS⁺ series consistently ensure a degree of protection to at least IP 65, which makes them suitable for many diverse applications.

Durable

The mechanical design of all actuators is optimally suited for long-lasting operation even in heavily used panels.

Mounting hole

The actuators in the RAFIX 22 FS⁺ series are suitable for 22.3 mm panel cut-outs according to IEC 60947-5-1.

All actuators are equipped with a locating pip. This locating pip ensures a perfect fit for actuators and contact blocks with PCB-mounted components and is therefore essential for designs including these contact blocks.

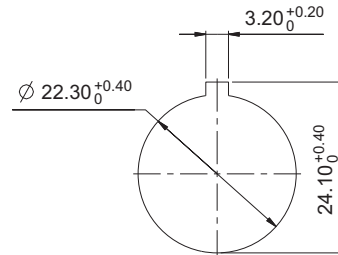

Grid spacing

The design principle makes it possible to use a minimum grid spacing of 30 mm x 30 mm. In such an arrangement, actuators with square collars can be aligned directly without any gaps.

When choosing the grid spacing, it is recommended to consider any external legending required (for example, using label strips inserted into the front panel).

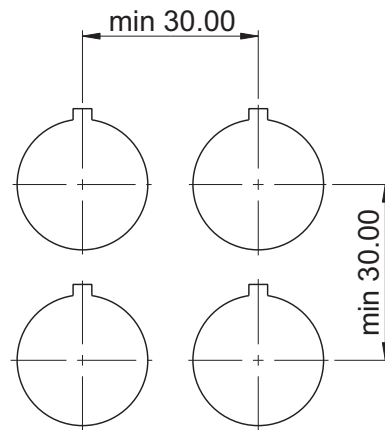

RAFIX 22 FS⁺ PCB

PCB contact blocks

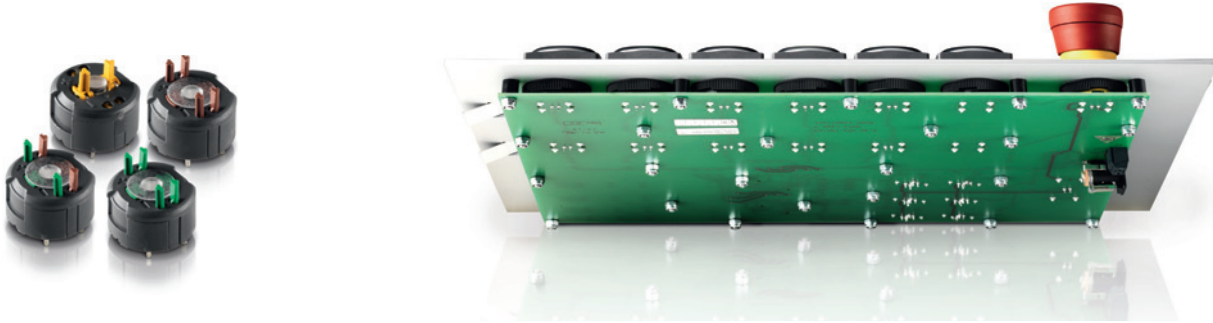

2

Dimensional drawing with PCB contact block

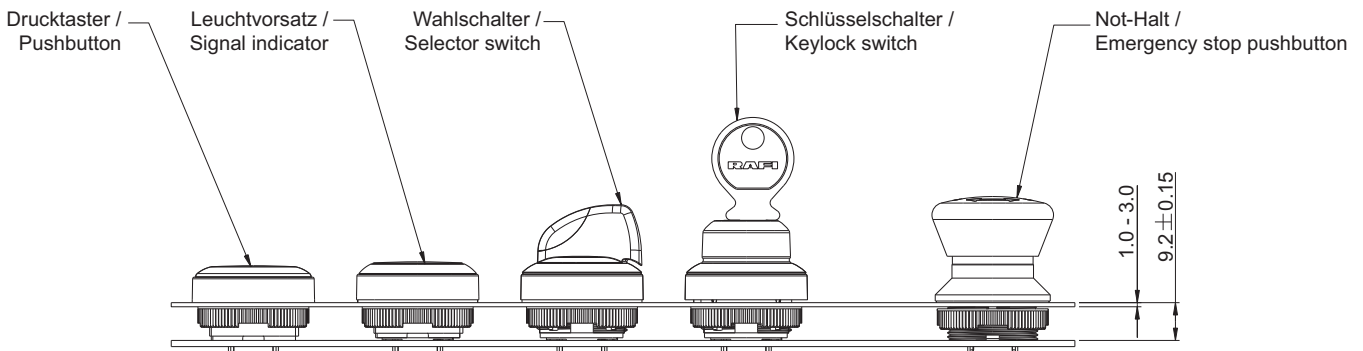

<p>Formula for spacer length</p> $\frac{9.2 \text{ mm} - \text{Front panel thickness}}{\text{Length of spacer}}$
--

RAFIX
22 FS⁺

PCB contact blocks

A printed circuit board is the best and fastest solution, starting with medium quantities. In addition, PCB contact blocks can be ideally combined with displays, short-travel keyswitches and other electronics on a common printed circuit board. Designs with PCB contact blocks feature a distance between the front panel and printed circuit board of only 9.2 mm; the same applies to contact blocks with silver contacts for the mains voltage. The printed circuit board is attached to the front panel with bolts, while the contact blocks are almost fully immersed in the actuators. This gives the entire system a very low profile. Further benefits: individual wiring is not required, and it is no longer necessary to cut out the printed circuit board around the control components.

FAST: Simply include the PCB contact blocks and LEDs in the layout of the printed circuit board and solder them during production – done as simply as with the other components on the common printed circuit board.

Assembly: Cost savings and reduction of assembly errors. The PCB contact blocks are soldered on the printed circuit board. Two options are available for actuator illumination:

1. A 3 mm THT LED that is inserted into the base of the contact block and soldered together with the contact block on the printed circuit board.
2. A separately placed SMT LED that produces light which is transported by the light conductor and distributed over the entire surface of the lens.

SLIM – enabling lean operation

Designs with PCB contact blocks feature a distance between the front panel and printed circuit board of only 9.2 mm; the same applies to contact blocks with silver contacts for the mains voltage. That's as slim as it gets.

CONTROL COMPONENTS

RAFIX 22 FS⁺ CONTROL COMPONENTS

RAFIX 22 FS⁺ PCB

Putting it all together

As part of the system design, the printed circuit board is attached to the front panel using threaded studs. This one-off construction measure ensures that no assembly errors can occur that would require subsequent troubleshooting. Very cost-effective for large quantities.

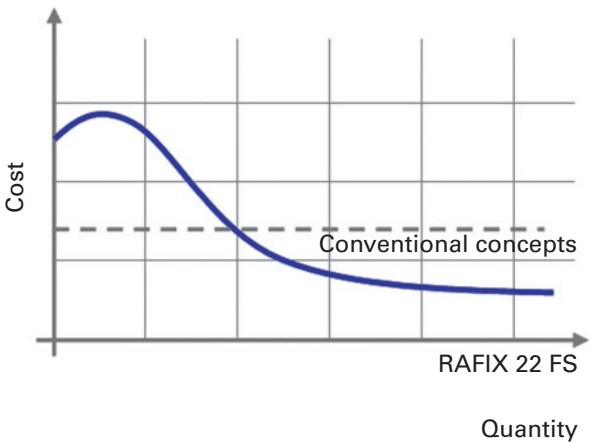

2

RAFIX 22 FS⁺

Spacers

A distance of 9.2 mm behind the front panel must be maintained. See the RAFI accessories for the necessary spacers.

Formula for spacer length

RAFIX 22 FS⁺ and RAFIX 22 FSR

$$\frac{9.2 \text{ mm} - \text{Front panel thickness}}{\text{Length of spacers}}$$

Benefits

- The extremely low mounting depth is unique and enables applications with entirely new housing and machine designs
- The series can be combined with RAFI short-travel keyswitches to tailor the operation to particular customer applications
- Standardised production with printed circuit boards pays off for large quantities and cuts assembly costs

Optimal applications meet the following conditions

- Usage of a printed circuit board is already planned. Printed circuit boards pay off for large quantities since production can be standardised.
- Short-travel keyswitches are used. RAFIX FS PCB contact blocks can be combined, for example, with RAFI short-travel keyswitches from the series MICON 5, RACON 8/12, RF 15/19 and KN 19.
- Tight space requirements: RAFIX FS technology can be used to realise smaller housing formats. This leads to savings on materials as well as tool costs.

Key points at a glance

- Mounting depth only 9.2 mm
- PCB contact blocks with printed circuit board THT terminal
- Gold contacts for totally reliable switching at low voltages (min. 5 V / 1 mA) or
- Silver contacts (max. 250 V / 4 A) for mains voltage
- Contact assignments: 1 NC, 1 NO, 2 NC, 2 NO, 1 NC + 1 NO, or for safety-relevant applications 2 NC + 1 NO (emergency stop "Plus 1")
- Illumination with LEDs in various colours
- Compatible with all RAFIX 22 FS⁺, RAFIX 22 FSR and RAFIX FS 30 actuators such as pushbuttons, selector switches, keylock switches, emergency stop buttons and signal indicators with all the benefits of this series



Combination of RAFIX 22 FS⁺ with RAFI short-travel keyswitches on a common printed circuit board

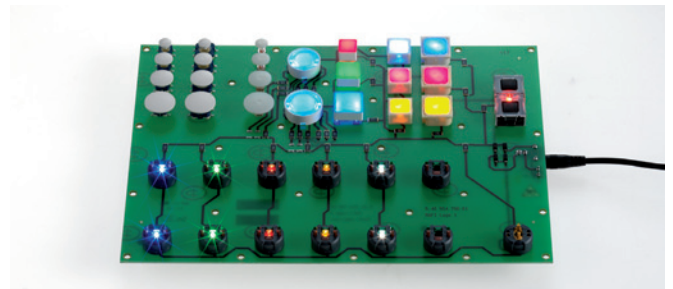

Top half: RAFI short-travel keyswitches RACON 8/12, MICON 5, RF 15/19, short-travel mains switch KN 19
Bottom half: RAFIX FS contact blocks, some with 3 mm THT LEDs

RAFIX 22 FS⁺ QC

The system

For the actuators in the RAFIX 22 FS⁺, RAFIX 22 FSR and RAFIX 30 FS⁺ series, RAFI offers QC contact blocks with plug-in connection. All it takes is a “click” to latch the contact block into the fixed actuator for a solid connection.



The concept

In cases where usage of a printed circuit board is not feasible or cost-effective, QC contact blocks provide an economical alternative. Locating lugs on the contact block latch into the actuators with precision in the millimetres. Matching guides are arranged in the thread to ensure a solid connection. Wiring the contact block is easy due to the standard male quick-connect terminals. As an isolation aid, there is a middle fin which is also used as a guide for the optional LED clip.

The QC contact block rounds out the RAFIX 22 FS⁺, RAFIX 22 FSR and RAFIX 30 FS⁺ series, making them suitable for all customer requirements. Separately installed control devices can be **easily** integrated into the system **without any tools**, helping users to save space, work expense and materials.

Assembly

The colour marking on the actuator thread and contact block helps to prevent incorrect assembly, thereby simplifying the assembly process. Briefly press the contact block and it will securely latch into the actuator (“click to install”).

Benefits

- Very fast and simple attachment of QC contact blocks saves valuable assembly time.
- The fixed connection between the contact block and actuator is suitable for applications with tremors and vibrations.
- Cable harnesses can be preassembled with the contact blocks.

Optimal applications meet the following conditions

- Usage of a printed circuit board is not cost-effective, for example away from main control points (e.g. emergency stop application in a hazard area).
- Typical control components need to be installed quickly. The installation time is significantly shorter for RAFIX QC contact blocks than for other available control component concepts.
- Significant vibrations and tremors are present. All parts are solidly connected.
- Other components need an appropriate amount of space.

RAFIX FS QC: Key points at a glance

- Mounting depth only 27 mm including LED clip and cable lugs
- QC contact blocks with quick-connect/solder terminals 2.8 x 0.8 mm
- The QC contact block engages permanently with the actuator only at the time of final assembly
- Compatible with all RAFIX 22 FS⁺, RAFIX 22 FSR and RAFIX 30 FS⁺ actuators such as pushbuttons, selector switches, keylock switches, emergency stop buttons and signal indicators with all the benefits of this series
- Protection against contact for quick-connect terminals and cable lugs: short-circuit-proof even when the connection wires are under tensile strain
- Gold contacts for totally reliable switching at low voltages (min. 5 V / 1 mA) or
- Silver contacts (max. 250 V / 4 A) for mains voltage
- Contact assignments: 1 NC, 1 NO, 2 NC, 2 NO, 1 NC + 1 NO, or for safety-relevant applications 2 NC + 1 NO (emergency stop “Plus 1”)
- Illumination with replaceable and extremely bright LED clips in various LED colours, with quick-connect terminals 2.8 x 0.8 mm
- Actuators / contact blocks, signal indicators / lamp sockets and LED clips can be stocked separately and are not connected until final assembly. In this manner, the product range ensures maximum flexibility along with economical inventory management.

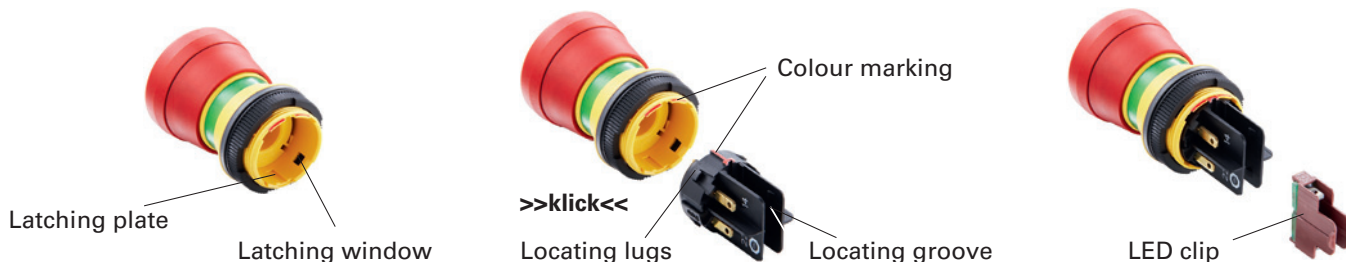

CONTROL COMPONENTS

RAFIX 22 FS⁺ CONTROL COMPONENTS

RAFIX 22 FS⁺ QC

Dimensional drawing with QC contact block

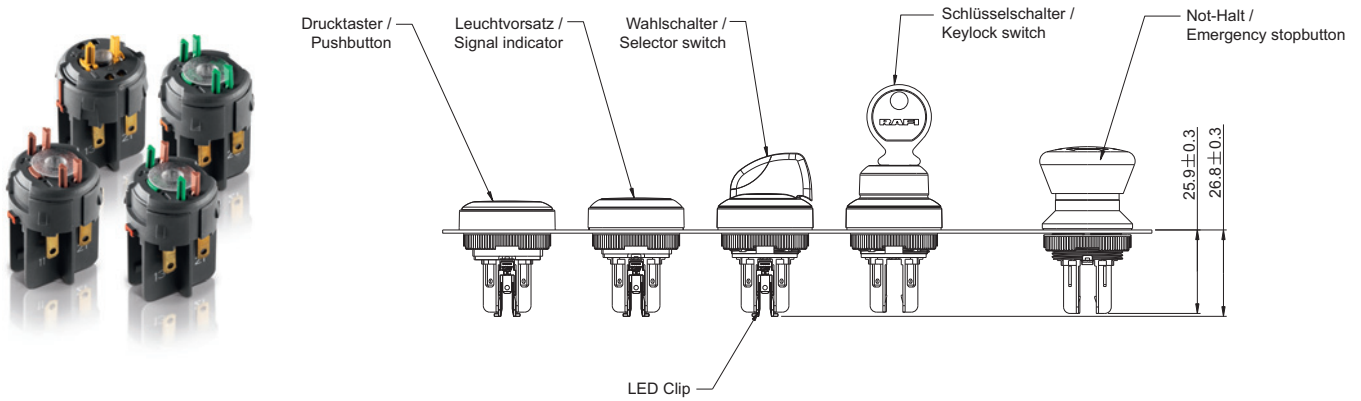

Terminal diagram (view from below)

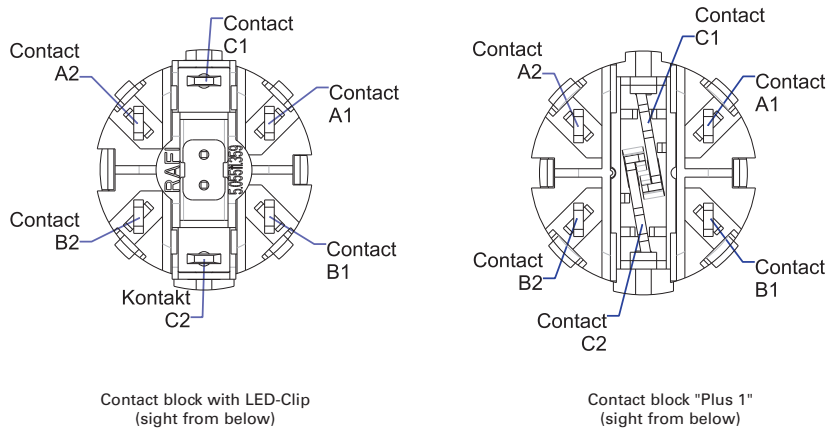

Contact arrangement	1NO	1NC	2NO	2NC	1NC + 1NO	Plus 1
Contact A1/A2 Terminal legending	1NO 13 - 14	-	1NO 13 - 14	1NC 11 - 12	1NO 13 - 14	1NC 11 - 12
Contact B1/B2 Terminal legending	-	1NC 21 - 22	1NO 23 - 24	1NC 21 - 22	1NC 21 - 22	1NC 21 - 22
Contact C1/C2 Terminal legending *:only when needed	LED* X1 - X2	LED* X1 - X2	LED* X1 - X2	LED* X1 - X2	LED* X1 - X2	1NO 33 - 34

Contact diagram for selector and keylock switches

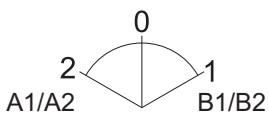

All actuators with 3 switch positions

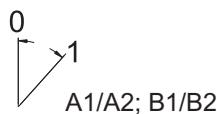

All actuators with 2 switch positions