



Chipsmall Limited consists of a professional team with an average of over 10 year of expertise in the distribution of electronic components. Based in Hongkong, we have already established firm and mutual-benefit business relationships with customers from,Europe,America and south Asia,supplying obsolete and hard-to-find components to meet their specific needs.

With the principle of “Quality Parts,Customers Priority,Honest Operation,and Considerate Service”,our business mainly focus on the distribution of electronic components. Line cards we deal with include Microchip,ALPS,ROHM,Xilinx,Pulse,ON,Everlight and Freescale. Main products comprise IC,Modules,Potentiometer,IC Socket,Relay,Connector.Our parts cover such applications as commercial,industrial, and automotives areas.

We are looking forward to setting up business relationship with you and hope to provide you with the best service and solution. Let us make a better world for our industry!



## Contact us

Tel: +86-755-8981 8866 Fax: +86-755-8427 6832

Email & Skype: info@chipsmall.com Web: www.chipsmall.com

Address: A1208, Overseas Decoration Building, #122 Zhenhua RD., Futian, Shenzhen, China



# 110Connect Enhanced Category 5 Jacks

406372-X, 406374-X

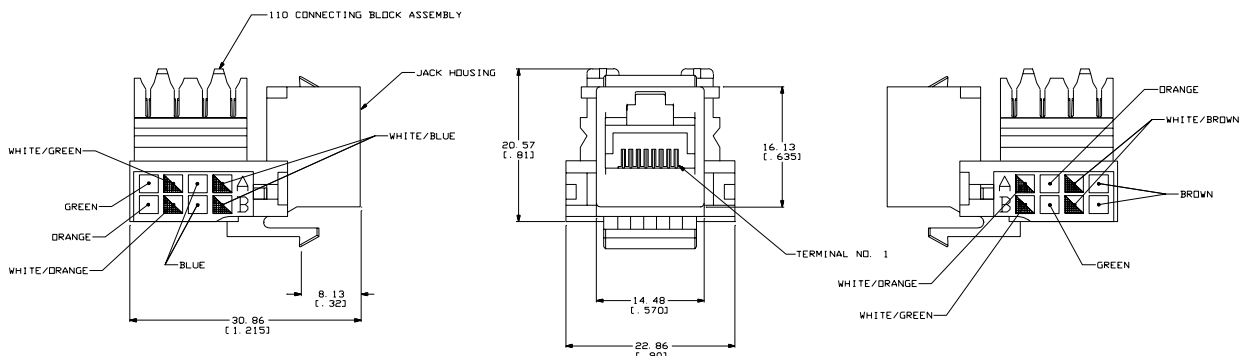

## Description

AMP Enhanced Category 5 110Connect Modular Jacks exceed the TIA requirements for Category 5e performance. They comply with all of the performance requirements for current and proposed applications such as Gigabit Ethernet, 100BASE-Tx, token ring, 155 Mbps ATM, 100 Mbps TP-PMD, ISDN, analog (broadband [550 MHz], baseband) and digital video and voice. The universal wiring label permits field installation to either T568A or T568B wiring while simplifying ordering and inventory. The 110Connect punchdown blocks are compatible with both 110 and Krone single wire tools.

## Specification (Text in brackets [ ] requires a choice.)

Modular jacks shall be [unkeyed or keyed], 4-pair and shall meet the performance requirements listed in the following table [include Performance Characteristics table from back page] in addition to all other standard Category 5 performance requirements. Modular jacks shall fit in a .790" X .582" opening. Modular jacks shall be terminated using a 110-style pc board connector, color-coded for both T568A and T568B wiring. Each jack shall be wired to [T568A or T568B]. Modular jacks shall be UL Listed under file number E81956. Modular jacks shall be AMP NETCONNECT part number [406372-X or 406374-X (X indicates color)].

Part Number	Description
406372-X	Category 5e modular jack, unshielded, unkeyed
406374-X	Category 5e modular jack, unshielded, keyed

X denotes color: -1 = Almond, -2 = Black, -3 = White, -4 = Gray, -5 = Orange, -6 = Blue, -7 = Red, -8 = Yellow, -9 = Green, 1-0 = Violet, 1- -1 = Electrical Ivory

# 110Connect Enhanced Category 5 Jacks

## 406372-X, 406374-X

### Typical Worst-Case Performance Characteristics (exceed TIA/EIA-568-B.2 Category 5e)

Frequency, MHz	Attenuation, dB		NEXT, dB		PS NEXT, dB		FEXT, dB		Return Loss, dB	
	Spec	AMP	Spec	AMP	Spec	AMP	Spec	AMP	Spec	AMP
1	0.1	0.03	65.0	84.7	–	82.7	65.0	79.7	35.0	55.9
4	0.1	0.03	65.0	74.1	–	71.7	63.1	71.8	35.0	50.3
8	0.1	0.03	64.9	68.2	–	66.0	57.0	66.2	35.0	45.7
10	0.1	0.03	63.0	66.2	–	64.0	55.1	64.3	35.0	44.0
16	0.2	0.04	58.9	62.2	–	60.0	51.0	60.5	35.0	40.5
20	0.2	0.05	57.0	60.2	–	58.0	49.1	58.6	34.0	38.8
25	0.2	0.06	55.0	58.2	–	56.0	47.1	56.7	32.0	37.0
31.25	0.2	0.07	53.1	56.2	–	54.1	45.2	54.8	30.1	35.2
62.5	0.3	0.07	47.1	49.9	–	47.4	39.2	48.9	24.1	29.7
100	0.4	0.11	43.0	46.5	–	43.2	35.1	44.7	20.0	26.2

#### Durability:

Modular jack - 750 mating cycles  
 110 Block - 200 termination cycles

#### Materials:

Housing - polyphenylene oxide, 94V-0 rated.  
 110 Blocks - polycarbonate, 94V-0 rated.

Jack contacts - phosphorous bronze, plated with 1.27 µm [.000050] thick gold in localized area and 3.81 µm [.000150] minimum thick tin-lead in solder area over 1.27 µm [.000050] minimum thick nickel underplate.

**Mounting panel thickness:** 1.473 - 1.600 mm [.058 - .063"].

**Packaging:** 1 per bag/25 bags per carton, weight - 0.87 lb/carton

**Approvals:** UL File Number E81956, CSA

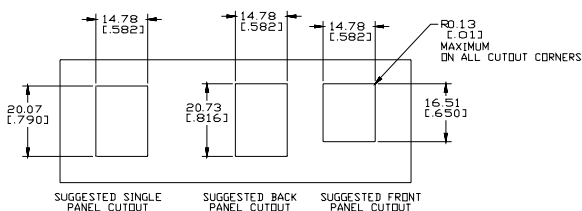

Specifications subject to change without notice.

Revised 11/01.

In the U.S. 1-800-553-0938

Canada 905-475-6222

Mexico 525-729-0400

South and Central Americas 54-11-4733-2200

www.ampnetconnect.com

e-mail: [networking.help@tycoelectronics.com](mailto:networking.help@tycoelectronics.com)

© Copyright 2001 Tyco Electronics Corporation. All rights reserved.  
 AMP and NETCONNECT are trademarks.

**tyco**

Electronics

