



Chipsmall Limited consists of a professional team with an average of over 10 year of expertise in the distribution of electronic components. Based in Hongkong, we have already established firm and mutual-benefit business relationships with customers from,Europe,America and south Asia,supplying obsolete and hard-to-find components to meet their specific needs.

With the principle of “Quality Parts,Customers Priority,Honest Operation,and Considerate Service”,our business mainly focus on the distribution of electronic components. Line cards we deal with include Microchip,ALPS,ROHM,Xilinx,Pulse,ON,Everlight and Freescale. Main products comprise IC,Modules,Potentiometer,IC Socket,Relay,Connector.Our parts cover such applications as commercial,industrial, and automotives areas.

We are looking forward to setting up business relationship with you and hope to provide you with the best service and solution. Let us make a better world for our industry!



## Contact us

Tel: +86-755-8981 8866 Fax: +86-755-8427 6832

Email & Skype: info@chipsmall.com Web: www.chipsmall.com

Address: A1208, Overseas Decoration Building, #122 Zhenhua RD., Futian, Shenzhen, China



THIS DRAWING IS UNPUBLISHED. RELEASED FOR PUBLICATION JUN , 1996.  
 © COPYRIGHT 1996 By - ALL RIGHTS RESERVED.

LOC	DIST	REVISIONS					
		P	LTR	DESCRIPTION	DATE	DWN	APVD
J		A1	REVISED	ECR-15-005119	02APR2015	I.T	W.H

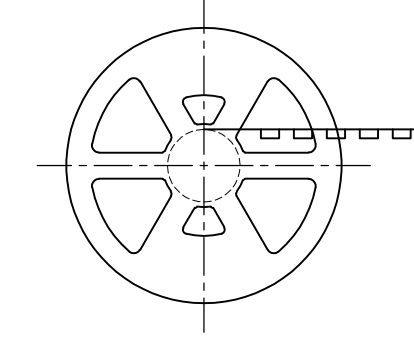
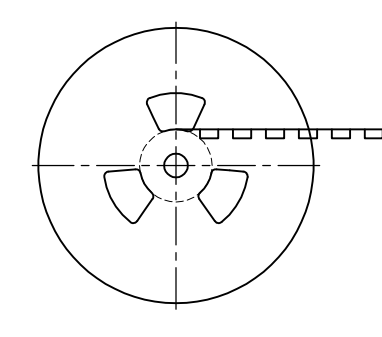
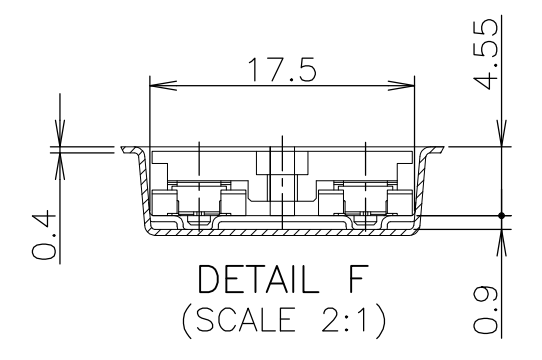
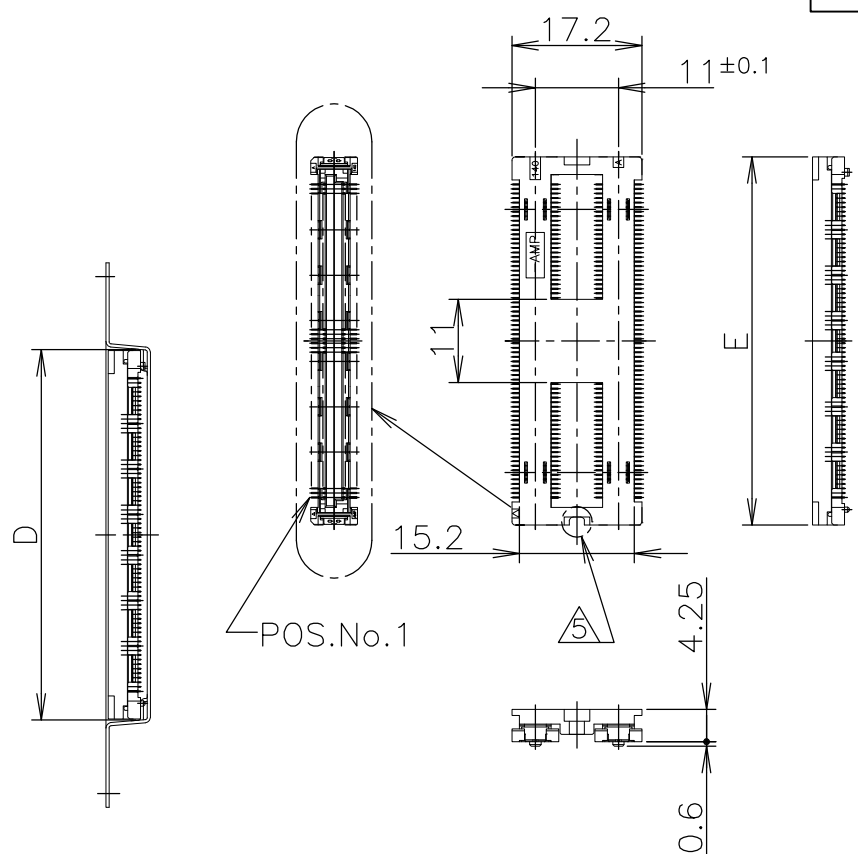
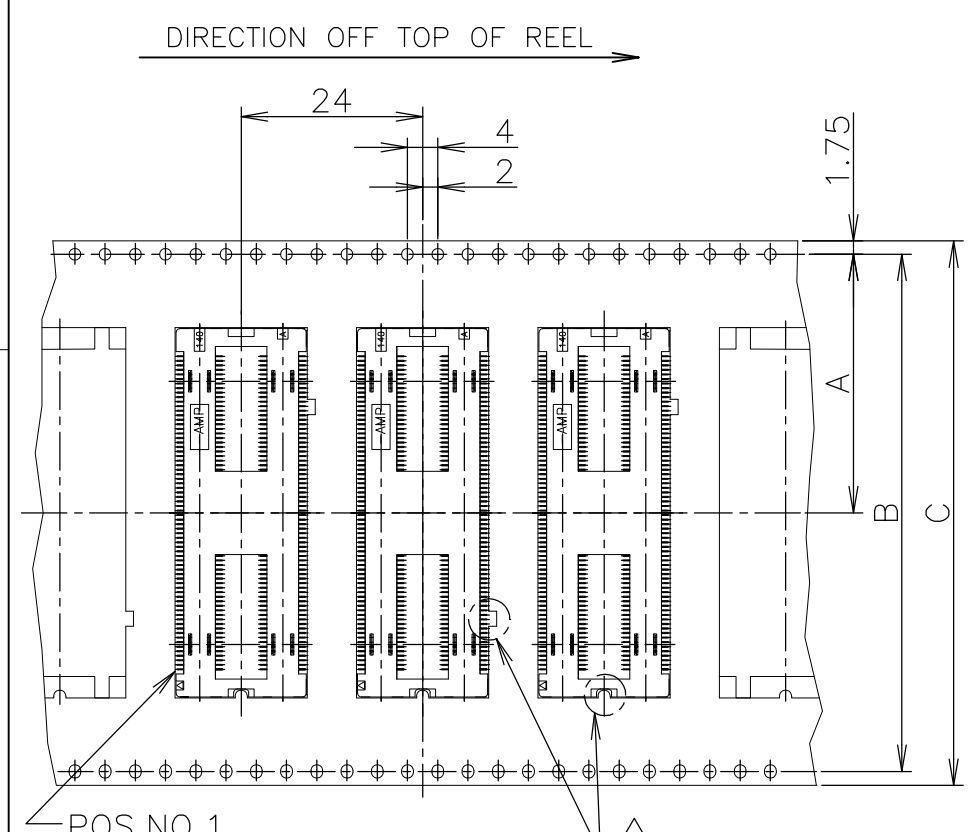

CONNECTOR DETAIL

PAPER REEL

PLASTIC REEL

DETAIL G

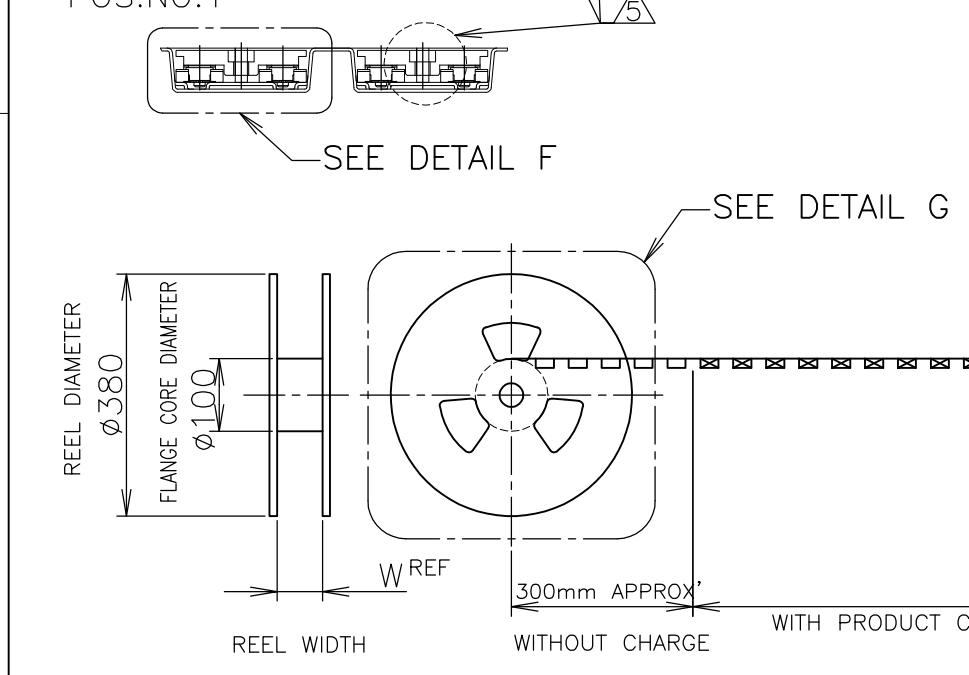

WEEDING THE COVER TAPE AROUND THE OUTER PERIPHERY IN A TURN.

SEALANT	REEL	TOOLING STATUS	QTY	W	E	D	C	B	A	POS.	PART NO.
---	NOT AVAILABLE		650	77.5	54.7	55	72	68.4	34.2	320	6-5353206-1
PAPER	AVAILABLE		↑	77.5	48.7	49	72	68.4	34.2	280	6-↑-0
---	NOT AVAILABLE		↑	61.5	42.7	43	56	52.4	26.2	240	5-↑-9
---	NOT AVAILABLE		650	61.5	36.7	37	56	52.4	26.2	200	5-5353206-8
---	NOT AVAILABLE		650	77.5	54.7	55	72	68.4	34.2	320	1-5353206-1
PLASTIC	AVAILABLE		↑	77.6	48.7	49	72	68.4	34.2	280	1-↑-0
---	NOT AVAILABLE		↑	61.5	42.7	43	56	52.4	26.2	240	↑-9
PAPER	NOT AVAILABLE		650	61.5	36.7	37	56	52.4	26.2	200	5353206-8

- 4 THIS PRODUCT WAS COATED BY FLUX-PENETRATION -INHIDITING AGENT.
- 5 CAP HOUSING AND EMBOSS TAPE FOR ONLY 280P HAS THESE ORIENTATION AND SUNK FEATURES.

THIS DRAWING IS A CONTROLLED DOCUMENT.

DWN HAWKING HE 14DEC04	 TE Connectivity	NAME 名称 I.ENOMOTO PRODUCT SPEC 製品規格 108-60047 APPLICATION SPEC 取付適用規格 114-5255	NAME 名称 EMBOSS ASSY FH 0.6BTB CONNECTOR REC 4H 2ROW TYPE W/G-CONT	SIZE A3 CAGE CODE 00779 DRAWING NO. 番号 C-5353206	RESTRICTED TO
CHK STEVEN YAO 14DEC04					
APVD I.ENOMOTO 14DEC04					
WEIGHT					

CUSTOMER DRAWING SCALE 1:1 SHEET 1 OF 3 REV A1



THIS DRAWING IS UNPUBLISHED.      RELEASED FOR PUBLICATION      JUN , 1996.  
 © COPYRIGHT 1996 By -      ALL RIGHTS RESERVED.

LOC	DIST	REVISIONS 変更			DATE	DWN	APVD
J		P	LTR	DESCRIPTION			
		-		SEE SHEET 1	-	-	-

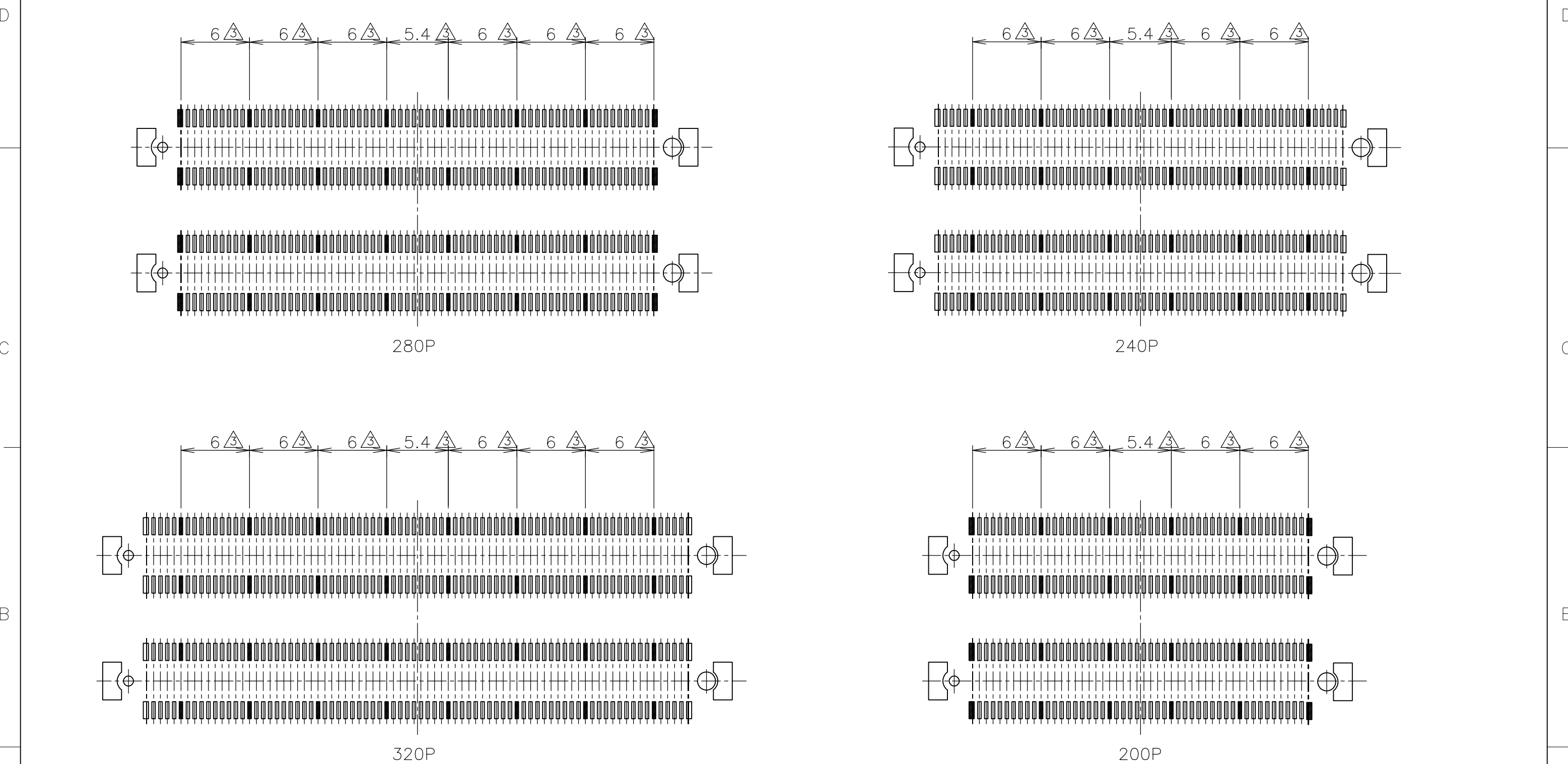

GENERAL TOLERANCE  
一般公差

10 ≥	±0.2
30 ≥	>10: ±0.25
100 ≥	>30: ±0.3
ANGLES: ±3°	

THIS DRAWING IS A CONTROLLED DOCUMENT.

DIMENSIONS: 単位: 耗 mm	TOLERANCES UNLESS OTHERWISE SPECIFIED: 一般公差
	0 PLC ± -
	1 PLC ± -
	2 PLC ± -
	3 PLC ± -
	4 PLC ± -
	ANGLES ± -
MATERIAL 材料	FINISH 仕上

DWN	TE Connectivity NAME 名称 EMOSS ASSY FH 0.6BTB CONNECTOR REC 4H 2ROW TYPE W/G-CONT			RESTRICTED TO			
CHK				SIZE	CAGE CODE	DRAWING NO 番号	
APVD				A3	00779	C-5353206	
PRODUCT SPEC 製品規格				CUSTOMER DRAWING			
APPLICATION SPEC 取付適用規格	SCALE 尺度 3:1			SHEET 3 OF 3			
WEIGHT	REV A1						