



Chipsmall Limited consists of a professional team with an average of over 10 year of expertise in the distribution of electronic components. Based in Hongkong, we have already established firm and mutual-benefit business relationships with customers from,Europe,America and south Asia,supplying obsolete and hard-to-find components to meet their specific needs.

With the principle of "Quality Parts,Customers Priority,Honest Operation,and Considerate Service",our business mainly focus on the distribution of electronic components. Line cards we deal with include Microchip,ALPS,ROHM,Xilinx,Pulse,ON,Everlight and Freescale. Main products comprise IC,Modules,Potentiometer,IC Socket,Relay,Connector.Our parts cover such applications as commercial,industrial, and automotives areas.

We are looking forward to setting up business relationship with you and hope to provide you with the best service and solution. Let us make a better world for our industry!



Contact us

Tel: +86-755-8981 8866 Fax: +86-755-8427 6832

Email & Skype: info@chipsmall.com Web: www.chipsmall.com

Address: A1208, Overseas Decoration Building, #122 Zhenhua RD., Futian, Shenzhen, China



PROPER USE GUIDELINES

Cumulative Trauma Disorders can result from the prolonged use of manually powered hand tools. Hand tools are intended for occasional use and low volume applications. A wide selection of powered application equipment for extended-use, production operations is available.

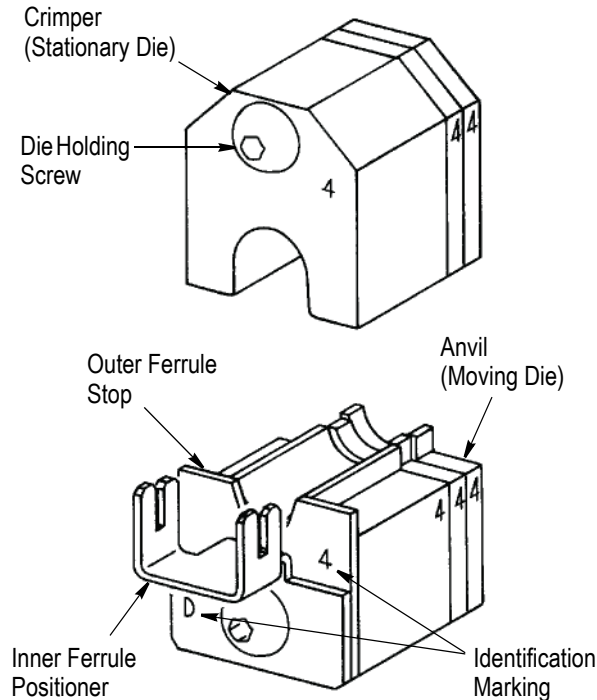

Figure 1

1. INTRODUCTION

Crimping Die Assemblies 543013-[] are designed to be used in Hand Crimping Tool Frame Assembly 543344-1 to crimp the inner ferrule and outer ferrule used with shielded cable clamp kits for AMPLIMITE* HD connectors.

This instruction sheet describes crimping procedures, insulation crimp adjustments, and maintenance and inspection. For information concerning the tool frame and die installation, refer to Instruction Sheet 408-9315 packaged with the tool frame. Read these instructions and referenced materials before using the die assembly.

NOTE

Measurements are in millimeters [with inches in brackets]. Figures and illustrations are for reference only and are not drawn to scale.

Reasons for reissue of this instruction sheet are provided in Section 6, REVISION SUMMARY.

2. DESCRIPTION

Each die assembly consists of an anvil (moving die) and a crimper (stationary die). The anvil features an inner ferrule positioner and an outer ferrule stop. Each die is held in the tool frame by a single screw. Refer to Figure 1.

When mated, the dies form a crimping chamber which simultaneously crimps the inner and outer ferrule onto the cable. The dies and the positioner have an identification marking to ensure proper die selection for the ferrules being crimped.

3. CRIMPING PROCEDURE
NOTE

The ferrules must be crimped before the contacts are crimped.

Determine the outside diameter of the cable being used, then refer to Figure 2 to select the appropriate inner and outer ferrule and then the corresponding die assembly. Observe the identification marking on the inner ferrule positioner which is also listed in Figure 2.

Prepare the cable according to the instructions packaged with the ferrules. Proceed as follows:

NOTE

Outer ferrule must be placed on the cable before stripping the cable.

1. Install the die assembly according to the instructions packaged with the tool frame. Hold the tool so that the FRONT side is facing you.
2. Open the dies by squeezing the tool handles together until the ratchet control releases.
3. Open the tool flip-top latch and insert the cable into the crimping chamber from the BACK side of the tool.
4. Make sure that the lip of the inner ferrule is in the slot in the positioner and the lip of the outer ferrule is against the stop. See Figure 3.
5. After the ferrules are properly positioned, close the tool flip-top latch.
6. Hold the cable assembly in place and squeeze the tool handles together until the ratchet releases.
7. Open the tool handles FULLY, open the flip-top latch, and remove the crimped assembly from the dies.



Damaged ferrules should not be used. If a damaged ferrule is evident, it should be replaced with a new one. Do NOT re-terminate ferrules.

4. MAINTENANCE AND INSPECTION

4.1. Maintenance

1. Remove dust, moisture, and other contaminants with a clean brush, or a soft, lint-free cloth. Do not use objects that could damage the dies.

2. Make sure that dies are properly aligned and that the die mounting screws are in place and secured.

3. Make certain that all surfaces are protected with a thin coat of any good SAE 20 motor oil. Do not oil excessively.

4. When dies are not in use, mate and store them in a clean, dry area.

CONNECTOR SIZE (No. of Positions)	CABLE DIAMETER RANGE	INNER FERRULE 745129 SUFFIX		OUTER FERRULE 745130 SUFFIX		DIE ASSEMBLY 543013 SUFFIX	POSITIONER-DIE MARKING
		LEADED	LEAD-FREE	LEADED	LEAD-FREE		
9	4.83-6.10 [.190-.240]	—	—	-8	-38	-1	A-1
		-18	-70	-8	-38	-2	B-1
	5.84-7.11 [.230-.280]	-34	-79	-16	-45	-17	B-8
	8.13-9.40 [.320-.370]	-17	-69	-10	-40	-6	B-3
15	4.83-6.10 [.190-.240]	-18	-70	-8	-38	-2	B-1
		-21	-73	-8	-38	-3	C-1
	5.84-7.11 [.230-.280]	-32	-78	-16	-45	-16	C-8
	7.62-8.89 [.300-.350]	-20	-72	-9	-39	-4	C-2
	8.00-9.27 [.315-.365]	-17	-69	-10	-40	-6	B-3
9.65-10.92 [.380-.430]	-19	-71	-11	-41	-7	C-4	
25	4.83-6.10 [.190-.240]	-21	-73	-8	-38	-3	C-1
	5.84-7.11 [.230-.280]	-32	-78	-16	-45	-16	C-8
	7.62-8.89 [.300-.350]	-20	-72	-9	-39	-4	C-2
		—	—	-9	-39	-5	D-2
	9.65-10.92 [.380-.430]	-19	-71	-11	-41	-7	C-4
		-23	-75	-11	-41	-8	D-4
11.94-13.46 [.470-.530]	-22	-74	-12	-42	-10	D-5	
37	4.83-6.10 [.190-.240]	-21	-73	-8	-38	-3	C-1
	5.84-7.11 [.230-.280]	-32	-78	-16	-45	-16	C-8
	7.62-8.89 [.300-.350]	-20	-72	-9	-39	-4	C-2
	9.65-10.92 [.380-.430]	-19	-71	-11	-41	-7	C-4
		—	—	-11	-41	-9	E-4
	11.81-13.34 [.464-.525]	-26	-76	-12	-42	-11	E-5
14.99-16.51 [.590-.650]	—	—	-13	-43	-13	E-6	
50	4.83-6.10 [.190-.240]	-18	-70	-8	-38	-2	B-1
	7.62-8.89 [.300-.350]	—	—	-9	-39	-5	D-2
	8.00-9.27 [.315-.365]	-17	-69	-10	-40	-6	B-3
	9.65-10.92 [.380-.430]	-23	-75	-11	-41	-8	D-4
	11.94-13.46 [.470-.530]	-22	-74	-12	-42	-10	D-5
		—	—	-12	-42	-12	F-5
	15.24-16.51 [.600-.650]	-29	-77	-13	-43	-14	F-6
17.78-19.05 [.700-.750]	—	—	-14	-44	-15	F-7	

Figure 2

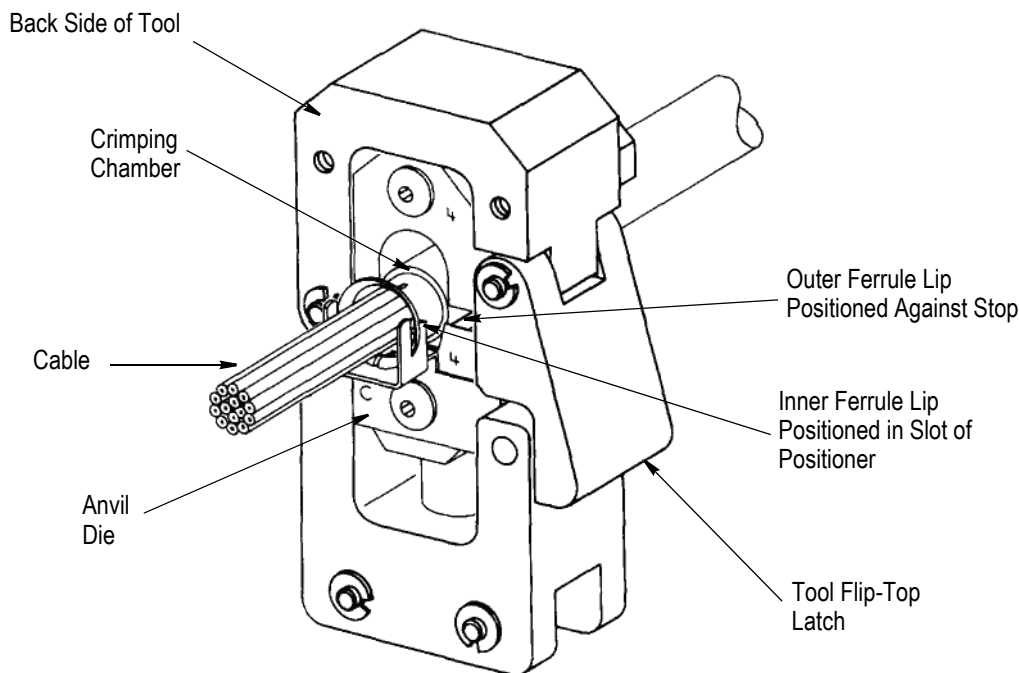

Figure 3

4.2. Inspection

Regular inspections should be performed with a record of inspections remaining with the dies and/or supervisory personnel responsible for them. Tyco Electronics recommends one inspection per month; however, amount of use, working conditions, operator training and skill, and established company standards should determine frequency of inspection. The inspection should be performed in the following sequence:

A. Visual Inspection

1. Remove all lubrication and accumulated film by immersing the dies in a suitable commercial degreaser that will not affect paint or plastic material.
2. Make sure all die mounting screws are in place and secured.
3. Check all bearing surfaces for wear. Replace worn dies. See Section 5, REPLACEMENT.
4. Inspect the crimping chamber for flattened, chipped, cracked, worn, or broken areas. If damage is evident, the dies must be replaced. See Section 5, REPLACEMENT.

B. Die Opening Inspection

This inspection requires the use of a vernier caliper. Proceed as follows:

1. Mate the dies until the crimping surfaces have bottomed; then hold in this position.
2. Using a vernier caliper, measure the die opening as shown in Figure 4.

If the die opening conforms to that shown in Figure 4, the dies are considered dimensionally correct and should be lubricated with a thin coat of any good SAE 20 motor oil. If not, the dies must be replaced. Refer to Section 5, REPLACEMENT.

5. REPLACEMENT

Order replacement dies through your Representative, or call 1-800-526-5142, or send a facsimile of your purchase order to 717-986-7605, or write to:

CUSTOMER SERVICE (38-35)
 TYCO ELECTRONICS CORPORATION
 PO BOX 3608
 HARRISBURG PA 17105-3608

6. REVISION SUMMARY

Revisions to this instruction sheet include:

- Updated instruction sheet to corporate requirements

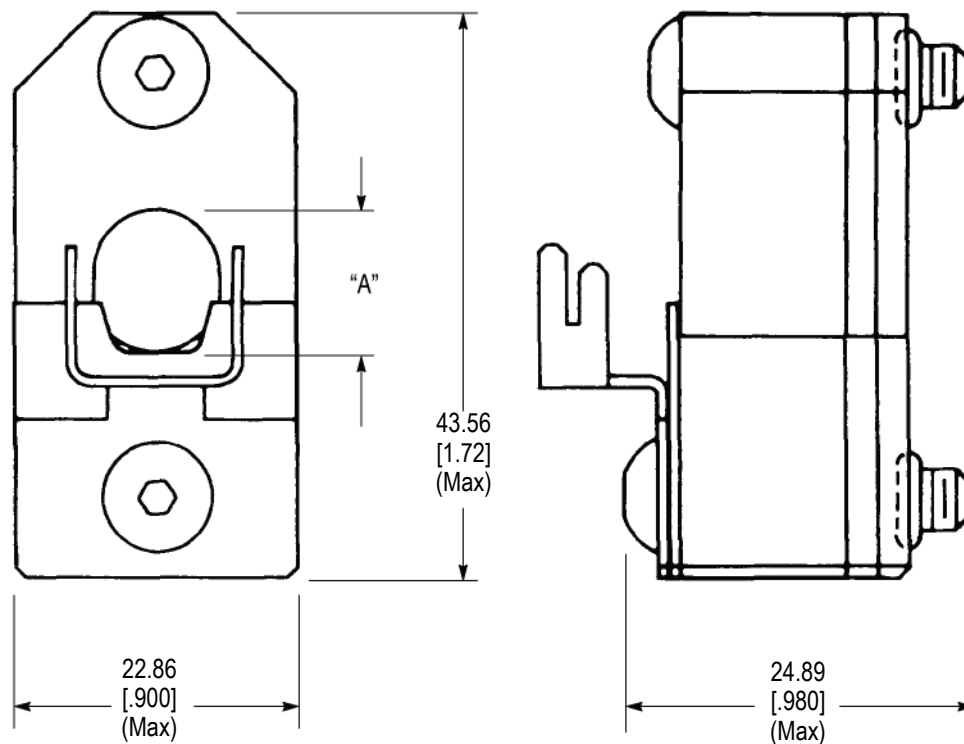

DIE SPECIFICATIONS

DIE ASSEMBLY 543013 SUFFIX	POSITIONER/DIE MARKING	DIE OPENING DIMENSION "A" (± 0.13 [± 0.005])
-1	A-1	6.10 [.240]
-2	B-1	
-3	C-1	
-4	C-2	8.51 [.335]
-5	D-2	
-6	B-3	9.19 [.362]
-7	C-4	
-8	D-4	10.59 [.417]
-9	E-4	
-10	D-5	13.34 [.525]
-11	E-5	
-12	F-5	
-13	E-6	16.48 [.649]
-14	F-6	
-15	F-7	19.02 [.749]
-16	C-8	
-17	B-8	6.78 [.267]

Figure 4