



Chipsmall Limited consists of a professional team with an average of over 10 year of expertise in the distribution of electronic components. Based in Hongkong, we have already established firm and mutual-benefit business relationships with customers from,Europe,America and south Asia,supplying obsolete and hard-to-find components to meet their specific needs.

With the principle of "Quality Parts,Customers Priority,Honest Operation,and Considerate Service",our business mainly focus on the distribution of electronic components. Line cards we deal with include Microchip,ALPS,ROHM,Xilinx,Pulse,ON,Everlight and Freescale. Main products comprise IC,Modules,Potentiometer,IC Socket,Relay,Connector.Our parts cover such applications as commercial,industrial, and automotives areas.

We are looking forward to setting up business relationship with you and hope to provide you with the best service and solution. Let us make a better world for our industry!



Contact us

Tel: +86-755-8981 8866 Fax: +86-755-8427 6832

Email & Skype: info@chipsmall.com Web: www.chipsmall.com

Address: A1208, Overseas Decoration Building, #122 Zhenhua RD., Futian, Shenzhen, China



© 1967 BY AMP INCORPORATED. ALL RIGHTS RESERVED. AMP PRODUCTS COVERED BY PATENTS AND/OR PATENTS PENDING. APPROVED PER GOVT CONTRACT NO.

LOCATION FOR AMP-TAB FEMALE CONTACT

CAVITY IDENTIFICATION ON TOP SURFACE OF HOUSING.
P/N (I)-582589-1 ONLY.

(I)-582589-1. SAME AS -1 EXCEPT TO HAVE CAVITY IDENTIFICATION ON TOP SURFACE OF HOUSING.

REVISIONS				
ZONE	LTR	DESCRIPTION	DATE	APPROVED
/	Y	ECO-08-020973	PY 11-08	JW

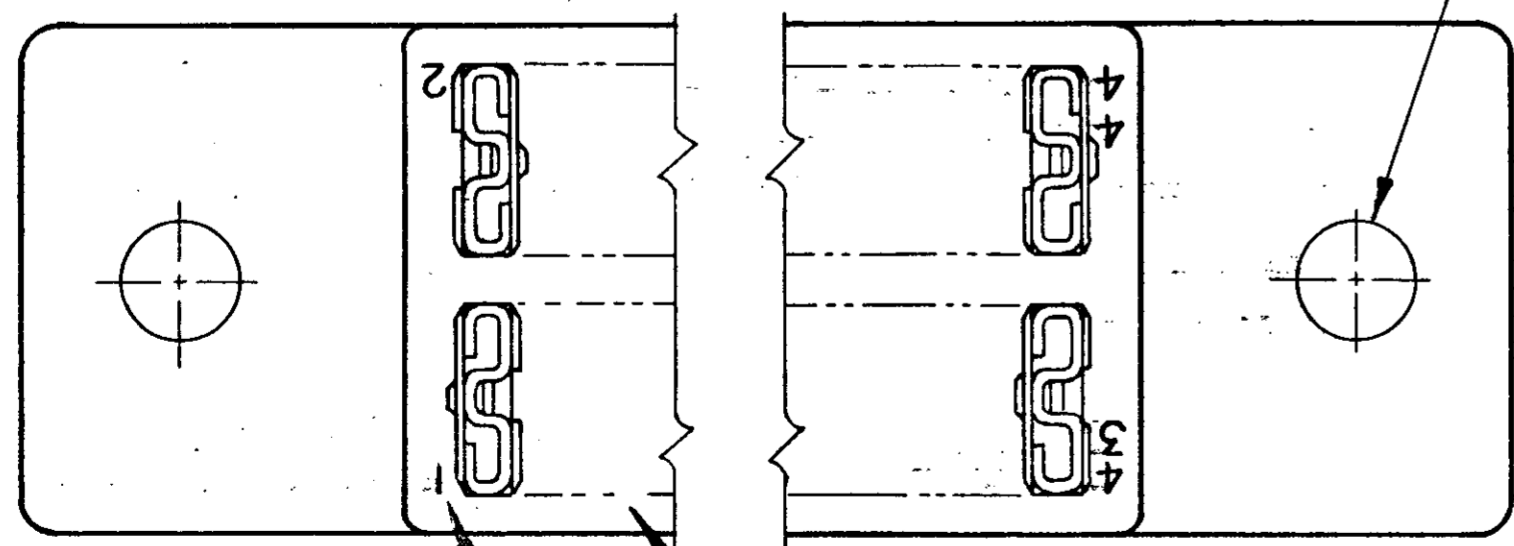
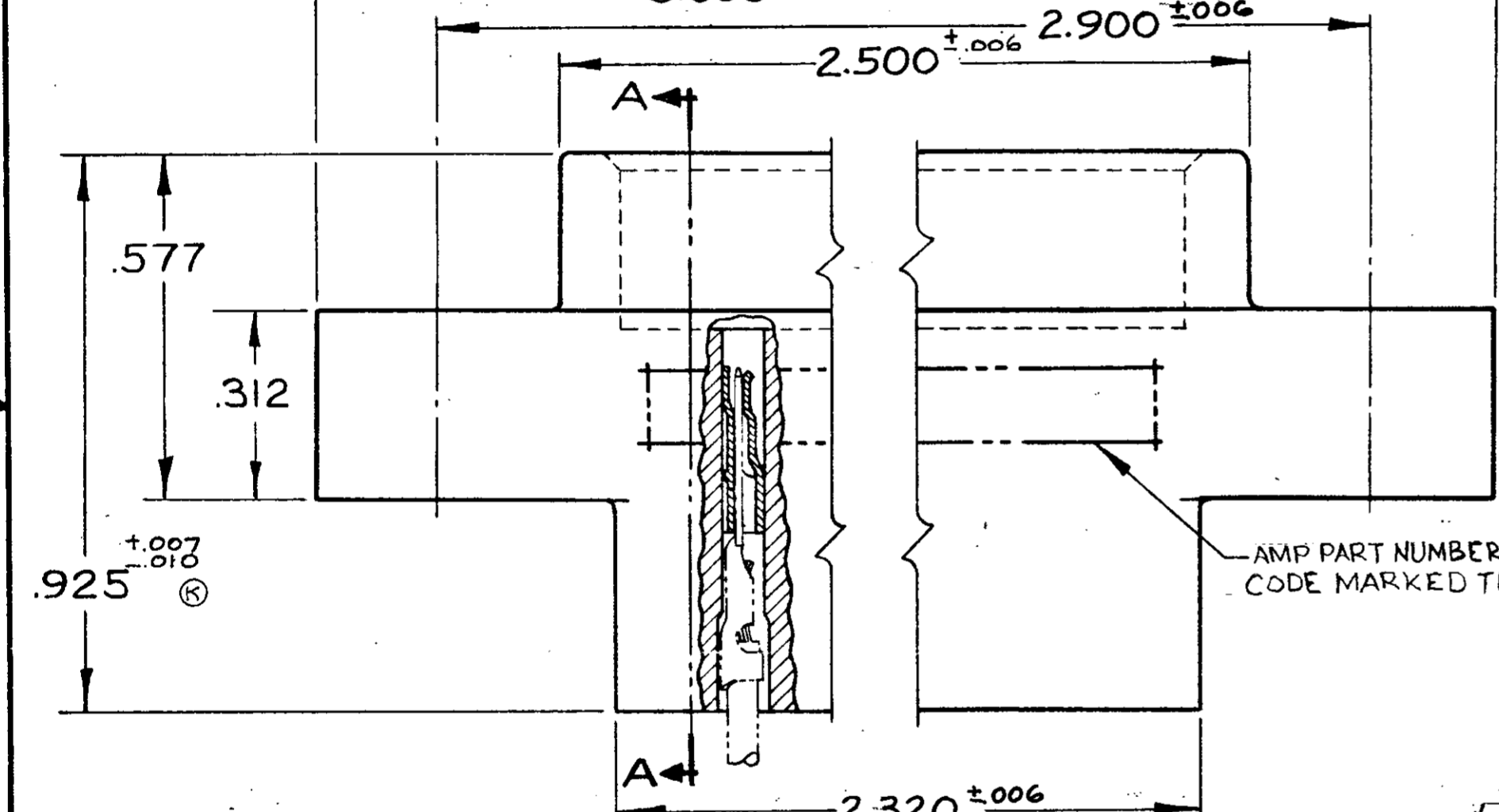
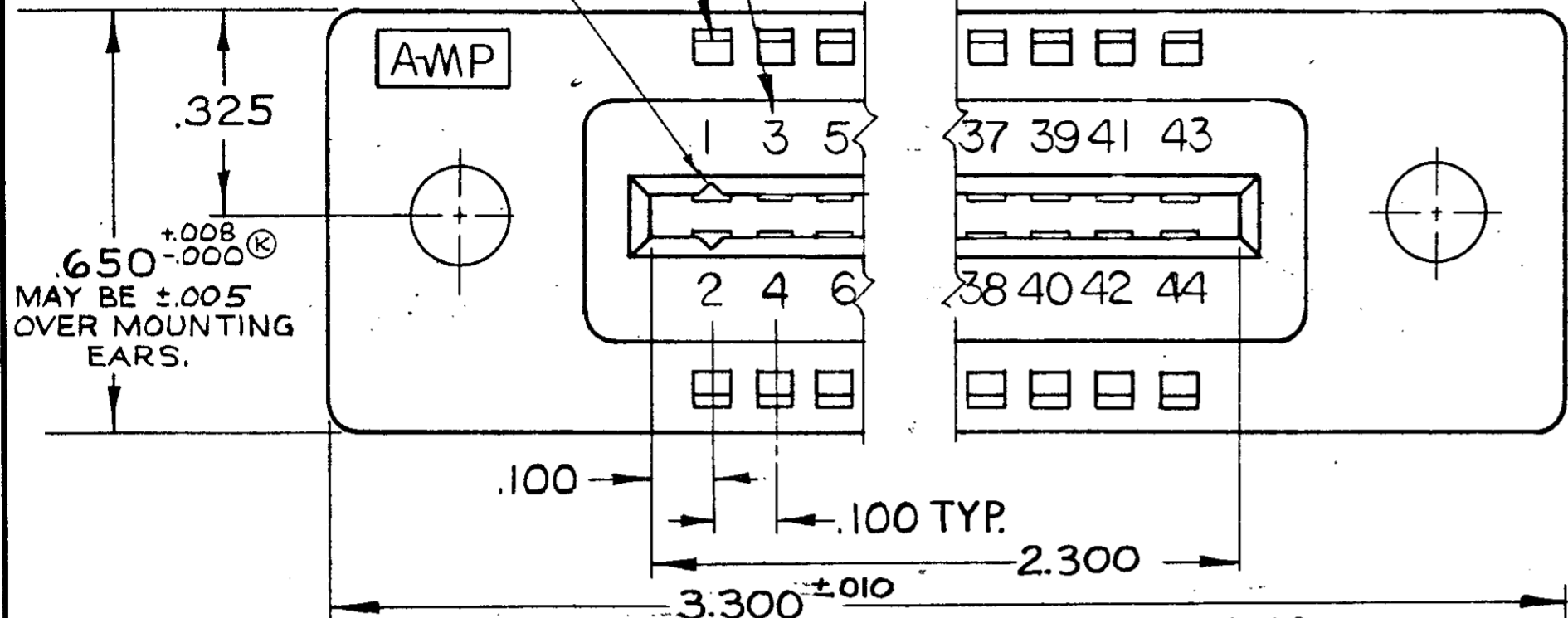

3. LASER MARKING ACCEPTABLE FOR ALL MARKING
- GROOVES FOR "ON CONTACT KEYING" AMP'S OPTION DEPENDING ON METHOD OF MANUFACTURE. FOR "ON CONTACT" KEYING USE KEYING PLUG P/N 583487-1. (MUST BE ORDERED SEPARATELY.)
 - MOUNTING EAR CONFIGURATION AMP'S OPTION DEPENDS ON METHOD OF MANUFACTURE.

- 582589-1 1 AS SHOWN "J" DIA. HOLES = .128
- obs 582589-2 1 SAME AS -1 EXCEPT 2 "J" DIA. HOLES = .156
- obs 582589-6 SAME AS 4 EXCEPT INK STAMPING ON TOP AND BOTTOM
- obsoLETE 582589-4 1 SAME AS -1 EXCEPT: 2. FLOATING BUSHINGS
- obs 582589-5 1 SAME AS -1 EXCEPT: FLOATING BUSHINGS REVERSED

CLEARANCE FOR #4 SCREW.

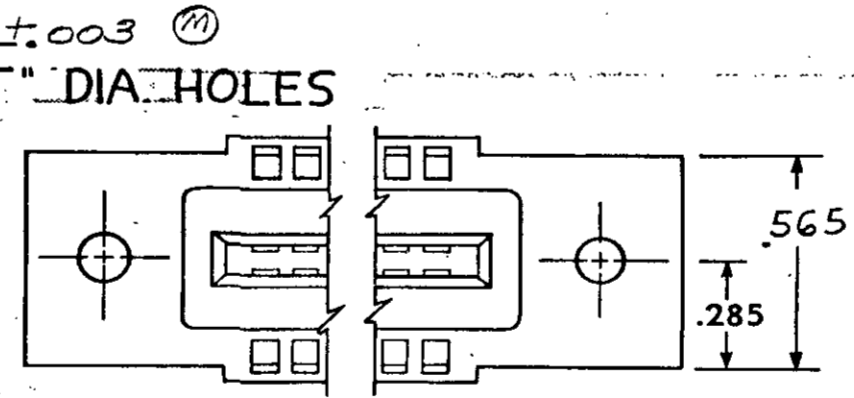
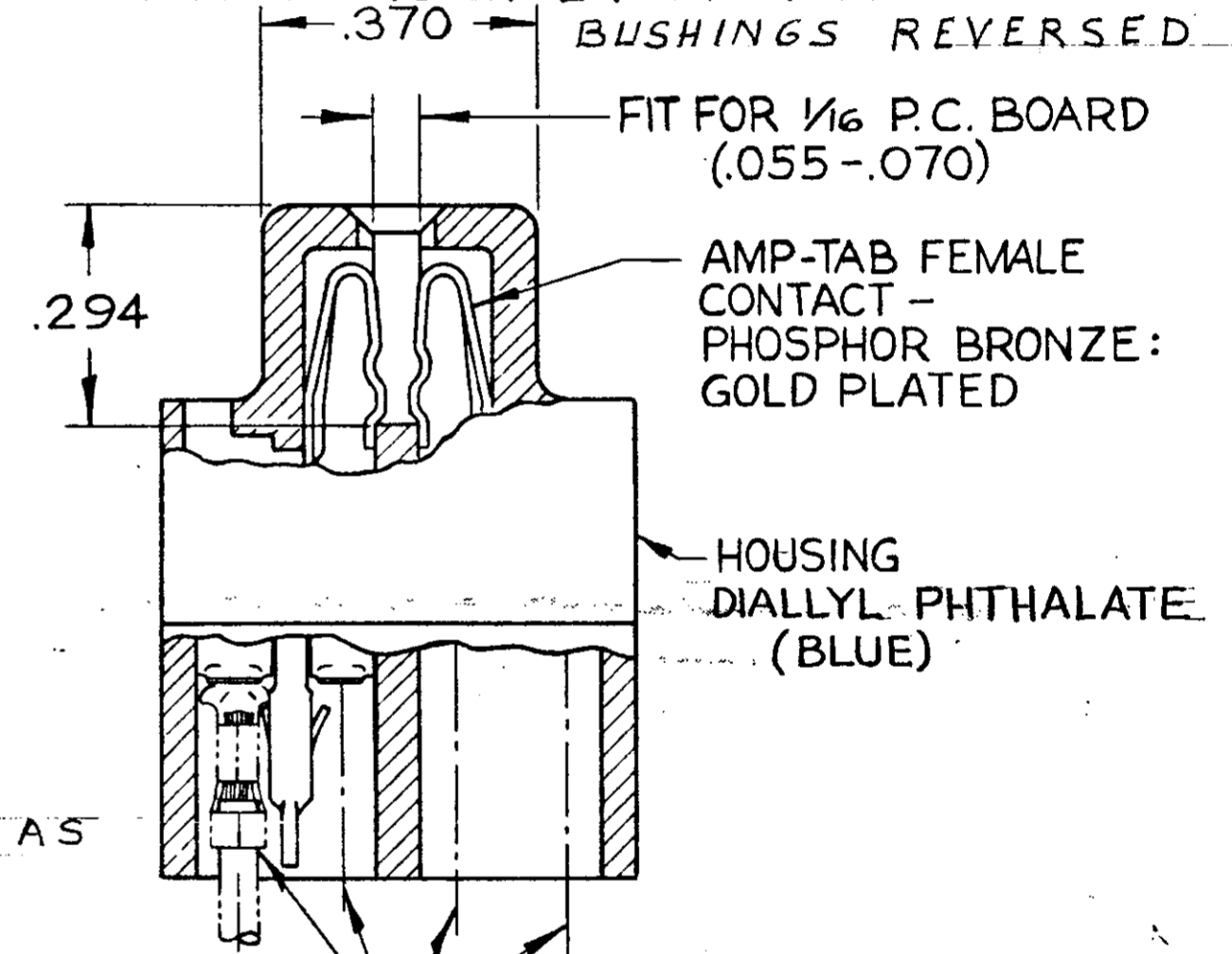
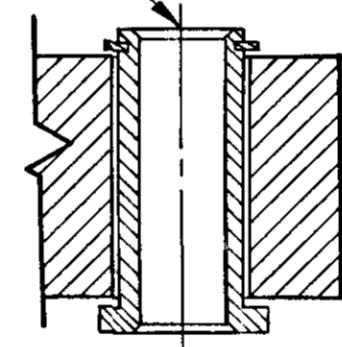

ALTERNATE MOUNTING EAR CONFIGURATION

CONTACT #66143 OR #66144 (NOTE: MAX. WIRE SIZE #20) (MUST BE ORDERED SEPARATELY)

CIRCUIT CAVITY IDENTIFICATION MARKING PER MIL-C-21097

MARK FIRST 5 POSITIONS, NEXT 5 POSITIONS PLAIN

UNLESS OTHERWISE SPECIFIED		CONTRACT NO.		AMP INCORPORATED	
DIMENSIONS ARE IN INCHES TOLERANCES ON				HARRISBURG, PENNSYLVANIA	
FRACTIONS	DECIMALS	ANGLES	DR	DATE	AMP TRADEMARK
±	±	±	<i>J. Asch</i>	12-16-66	22 POSITION AMP-TAB CONNECTOR .100 CENTERS QUAD
±	±.005	±	CHK <i>W. Burns</i>	DATE 1-5-67	
MATERIAL			DSGN ENGR	DATE	
SEE CALLOUT			<i>J. Kaufman</i>	1-10-67	
HEAT TREAT			APPD <i>R. Showman</i>	DATE 1/4/67	SIZE
FINISH			DSGN APPD	OTHER APPD	C 00779
SEE CALLOUT					NUMBER
					582589
					REV
					Y
SCALE 4-1 WT CALC ACTUAL SHEET					

AMP INFO
LOC PRINT DIST
DF FO