



Chipsmall Limited consists of a professional team with an average of over 10 year of expertise in the distribution of electronic components. Based in Hongkong, we have already established firm and mutual-benefit business relationships with customers from,Europe,America and south Asia,supplying obsolete and hard-to-find components to meet their specific needs.

With the principle of “Quality Parts,Customers Priority,Honest Operation,and Considerate Service”,our business mainly focus on the distribution of electronic components. Line cards we deal with include Microchip,ALPS,ROHM,Xilinx,Pulse,ON,Everlight and Freescale. Main products comprise IC,Modules,Potentiometer,IC Socket,Relay,Connector.Our parts cover such applications as commercial,industrial, and automotives areas.

We are looking forward to setting up business relationship with you and hope to provide you with the best service and solution. Let us make a better world for our industry!



Contact us

Tel: +86-755-8981 8866 Fax: +86-755-8427 6832

Email & Skype: info@chipsmall.com Web: www.chipsmall.com

Address: A1208, Overseas Decoration Building, #122 Zhenhua RD., Futian, Shenzhen, China



LOC		DIST		REVISIONS			
P	LTR	DESCRIPTION	DATE	DNW	APVD		
D		REVISED PER ECO-06-014732	13NOV06	KW	DC		

- ⚠ MATERIAL:
HOUSING: NYLON, UL94V-0 (COLOR - NATURAL, COLOR OF PARTS MAY VARY).
CONTACTS: 0.25 THK COPPER ALLOY.
- ⚠ CONTACT FINISH: 0.003 MIN THK TIN-LEAD OVER 0.00127 MIN THK NICKEL OVER ENTIRE CONTACT.
- ⚠ CONTACT FINISH: 0.00076 MIN THK GOLD PLATE ON PIN MATING SURFACE, 0.003 MIN THK TIN-LEAD PLATE ON SOLDER TAIL, ALL OVER 0.00127 MIN THK NICKEL BASE PLATE.
- 4. SOLDER TAIL MEETS AMP SOLDERABILITY SPECIFICATION 109-11-2.
- 5. MATES WITH SIMILARLY PLATED AMP-DUAC™ POWER CONNECTOR RECEPTACLE HOUSINGS/SOCKET CONTACTS.
- ⚠ RIBS ON FOUR CORNERS OPTIONAL.
- ⚠ AMP LOGO AND MATERIAL ID MAY BE LOCATED ON EITHER LONG SIDE OF PART.
- ⚠ SIZE, SHAPE OR STYLE OF THIS FEATURE MAY VARY.
- ⚠ CONTACT FINISH: 0.003 MIN THK TIN OVER 0.00127 MIN THK NICKEL OVER ENTIRE CONTACT.
- ⚠ CONTACT FINISH: 0.00076 MIN THK GOLD PLATE ON PIN MATING SURFACE, 0.003 MIN THK TIN PLATE ON SOLDER TAIL, ALL OVER 0.00127 MIN THK NICKEL BASE PLATE.

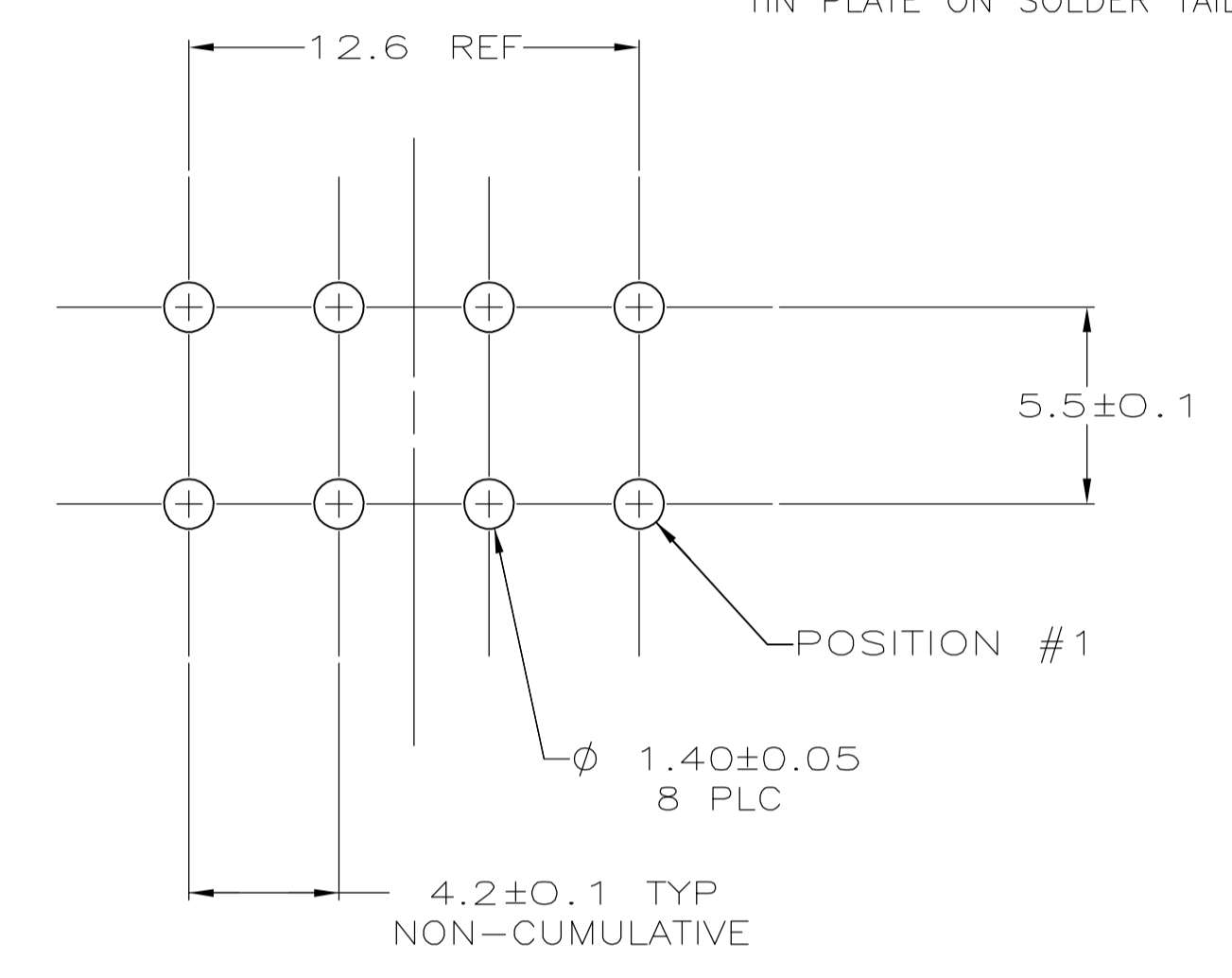
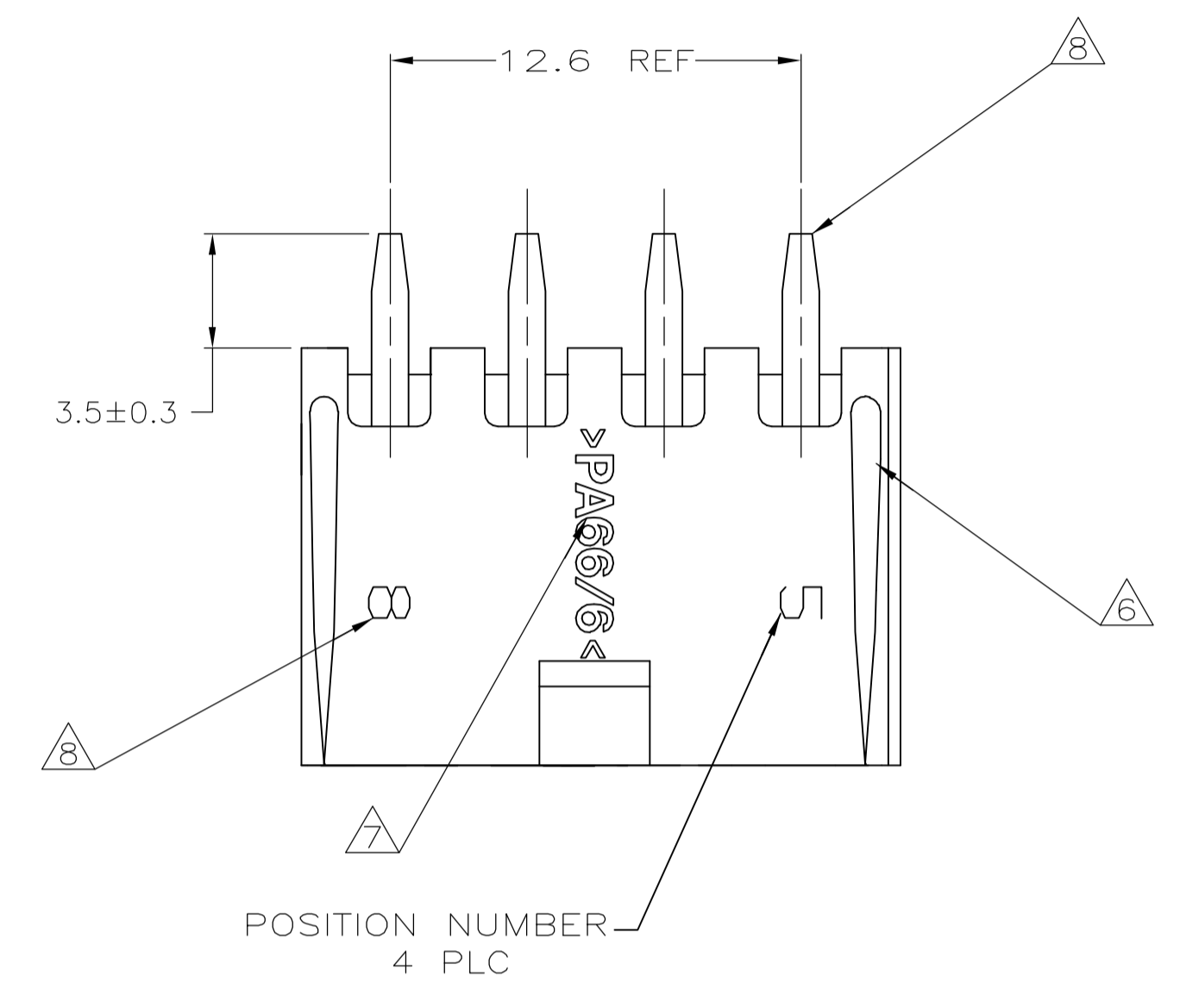

RECOMMENDED MOUNTING HOLE PATTERN FOR 1.78 MAX THICK P.C. BOARD COMPONENT SIDE SHOWN

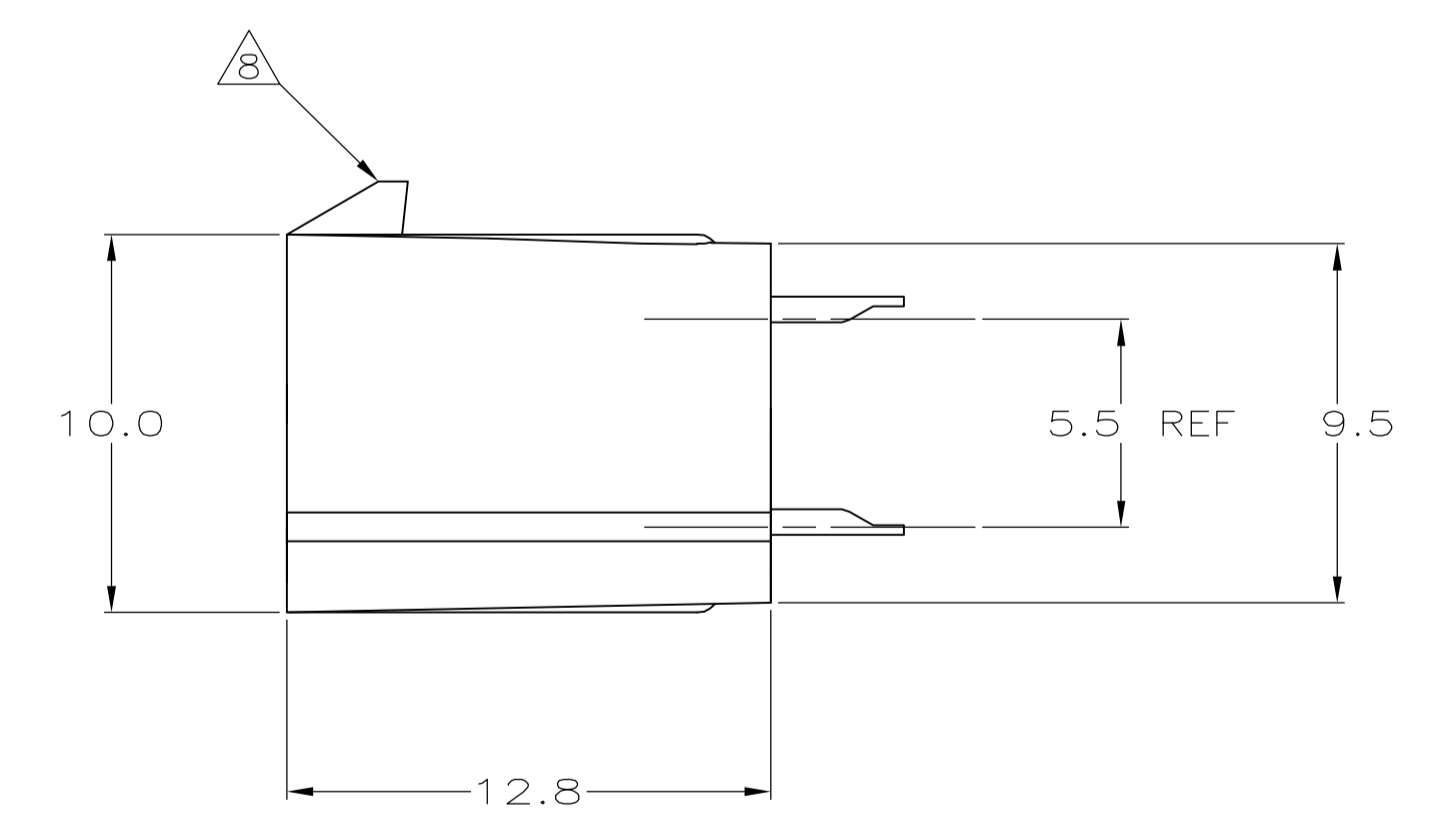
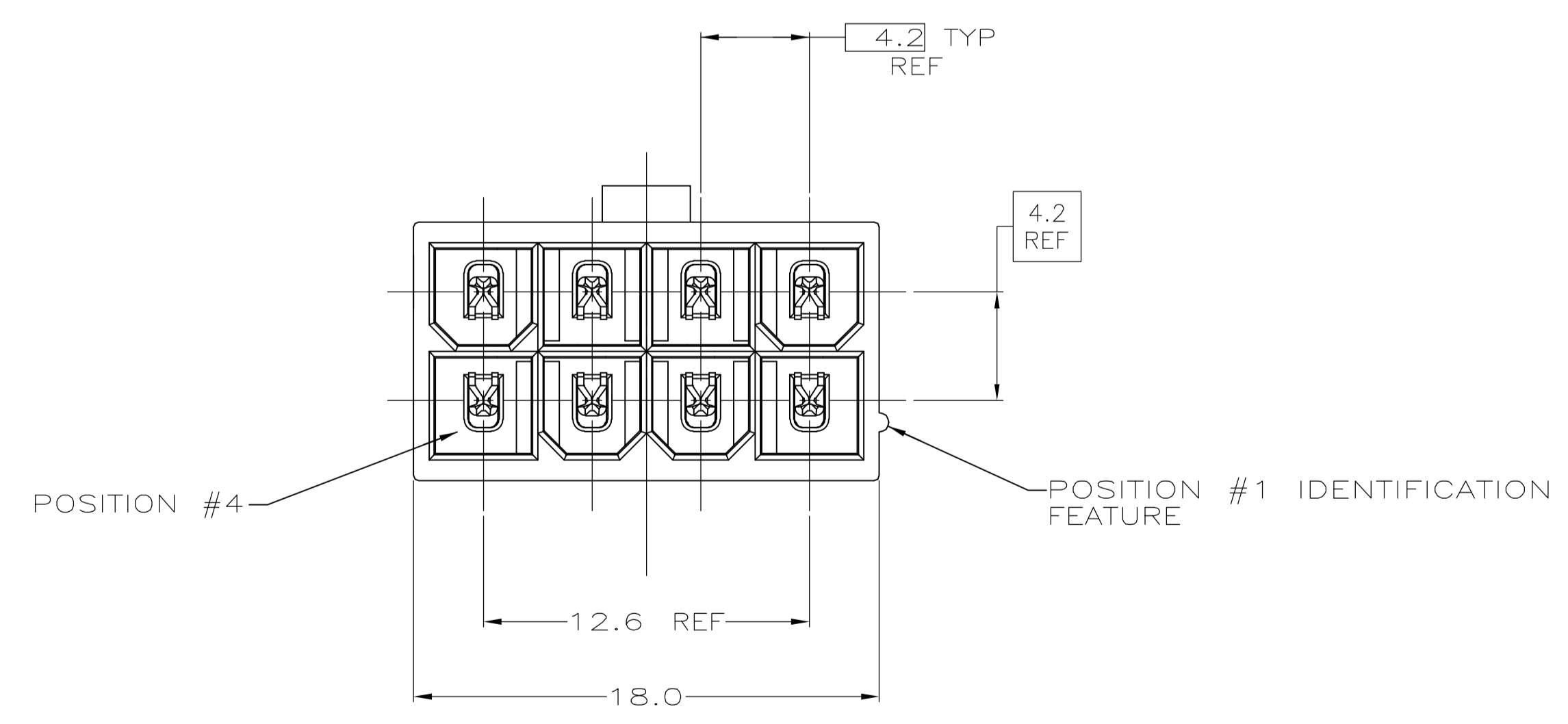

SUPERSEDED BY 1-794486-2
 SUPERSEDED BY 1-794486-1

⚠	⚠	⚠	⚠	1-794486-2
⚠	⚠	⚠	⚠	1-794486-1
⚠	⚠	⚠	⚠	794486-2
⚠	⚠	⚠	⚠	794486-1
MATERIAL	FINISH	MATERIAL	COLOR	PART NO

METRIC

THIS DRAWING IS A CONTROLLED DOCUMENT.

DIN R VESTAL 6-11-98	 Tyco Electronics Corporation Harrisburg, Pa 17105-3608		
CHK R SWING 6-11-98			
APVD C CASH 6-11-98	NAME		
PRODUCT SPEC 108-1699			
APPLICATION SPEC			
SIZE	CAGE CODE	DRAWING NO	RESTRICTED TO
—	—	A1 00779	794486
WEIGHT	—	SCALE	5:1
CUSTOMER DRAWING	SHEET	1 OF 1	REV D