



Chipsmall Limited consists of a professional team with an average of over 10 year of expertise in the distribution of electronic components. Based in Hongkong, we have already established firm and mutual-benefit business relationships with customers from,Europe,America and south Asia,supplying obsolete and hard-to-find components to meet their specific needs.

With the principle of “Quality Parts,Customers Priority,Honest Operation,and Considerate Service”,our business mainly focus on the distribution of electronic components. Line cards we deal with include Microchip,ALPS,ROHM,Xilinx,Pulse,ON,Everlight and Freescale. Main products comprise IC,Modules,Potentiometer,IC Socket,Relay,Connector.Our parts cover such applications as commercial,industrial, and automotives areas.

We are looking forward to setting up business relationship with you and hope to provide you with the best service and solution. Let us make a better world for our industry!



## Contact us

Tel: +86-755-8981 8866 Fax: +86-755-8427 6832

Email & Skype: info@chipsmall.com Web: www.chipsmall.com

Address: A1208, Overseas Decoration Building, #122 Zhenhua RD., Futian, Shenzhen, China



THIS DRAWING IS UNPUBLISHED. RELEASED FOR PUBLICATION 20  
 © COPYRIGHT 20 ALL RIGHTS RESERVED.

LOC	DIST	REVISIONS					
FT	0	P	LTR	DESCRIPTION	DATE	DWN	APVD
			DI	REVISED PER ECO-11-005294	06APR2011	RK	HMR

- 1. MATERIALS AND FINISH:  
 HOUSING: PA 6-6, UL 94-V0, COLOR:BLACK.  
 CLAMP: BRASS, NICKEL PLATED.  
 TERMINAL: BRASS, TIN PLATED.  
 CLAMPING SCREW: M3, BRASS, NICKEL PLATED.
- 2. SUITABLE FOR 1,6-2,4mm. PCB THICKNESS.
- 3. END-TO-END STACKABLE W/INTERLOCK WITHOUT LOSS OF CENTERLINE SPACING.
- 4. WIRE SIZE RANGE: 12 - 30 AWG
- 5. RECOGNIZED UNDER THE COMPONENT PROGRAM OF UNDERWRITERS LABORATORIES INC. FILE No E60677.
- 6. IMQ CERTIFICATE WITH SURVEILLANCE IN CONFORMITY WITH IEC 998-1/998-2-1.
- 7. NOT CUMULATIVE TOLERANCE.
- 8. WHITE INK STAMPING.
- 9. BUCHANAN LOGO TO APPEAR ON HOUSING, LOCATION OPTIONAL, WHERE SPACE PERMITS.

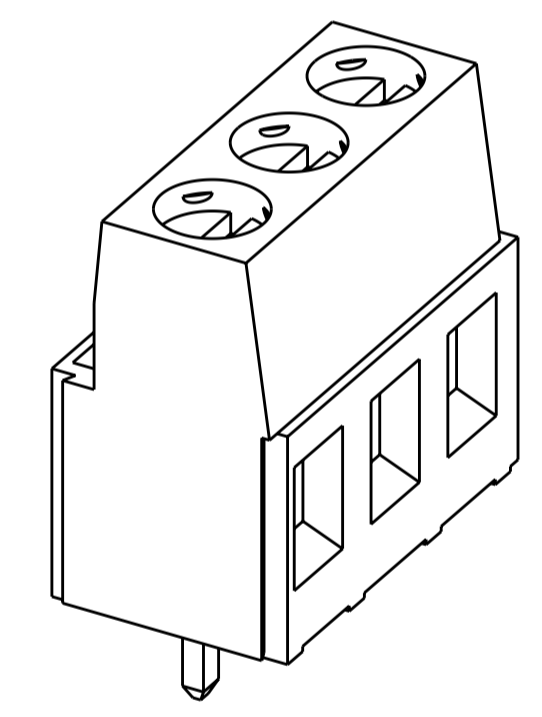
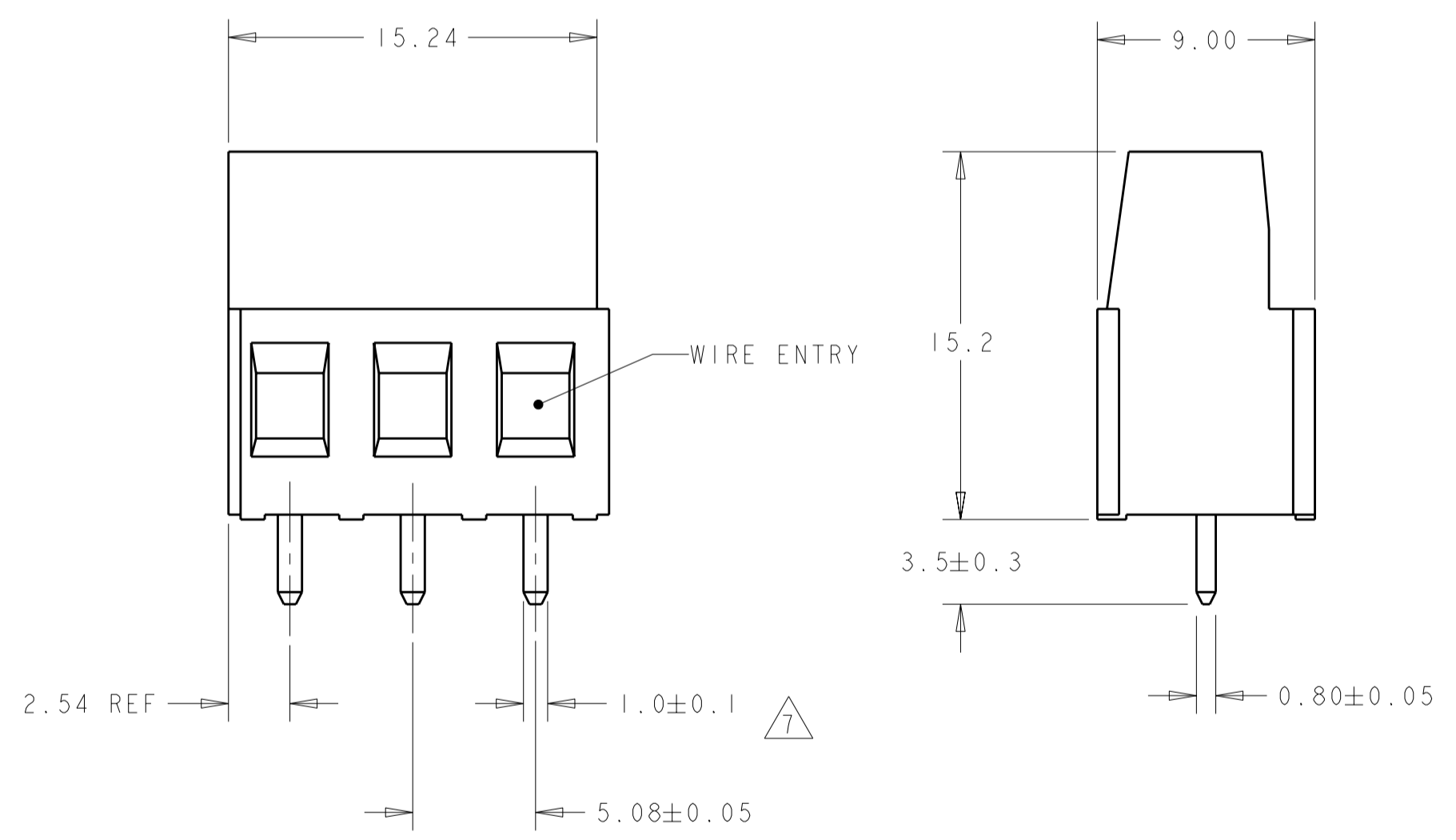
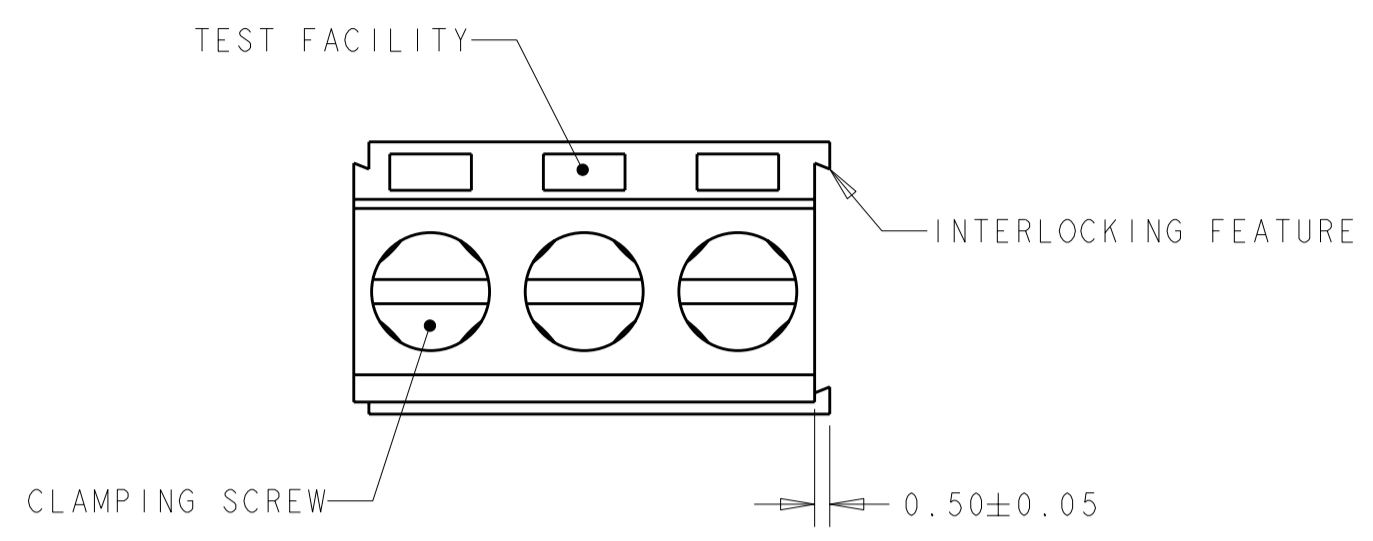

796949-3 AS SHOWN

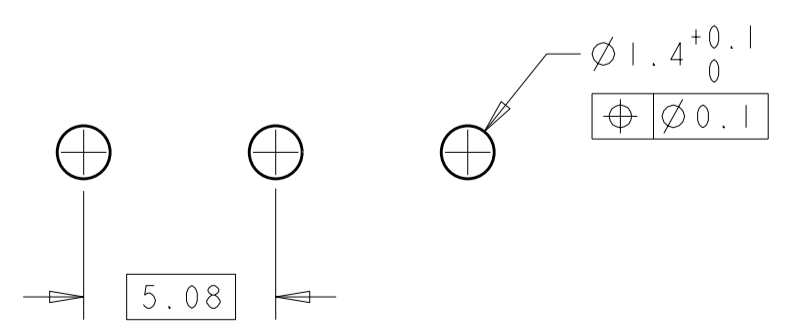

RECOMMENDED PC BOARD LAYOUT  
 SCALE 5:1

SEE DETAIL P	30.48	6	3-796949-1
SEE DETAIL N	10.16	2	3-796949-0
SEE DETAIL M	40.64	8	2-796949-9
SEE DETAIL L	40.64	8	2-796949-8
-	127.00	25	2-796949-5
-	121.92	24	2-796949-4
-	116.84	23	2-796949-3
-	111.76	22	2-796949-2
-	106.68	21	2-796949-1
-	101.60	20	2-796949-0
-	96.52	19	1-796949-9
-	91.44	18	1-796949-8
-	86.36	17	1-796949-7
-	81.28	16	1-796949-6
-	76.20	15	1-796949-5
-	71.12	14	1-796949-4
-	66.04	13	1-796949-3
-	60.96	12	1-796949-2
-	55.88	11	1-796949-1
-	50.80	10	1-796949-0
-	45.72	9	796949-9
-	40.64	8	796949-8
-	35.56	7	796949-7
-	30.48	6	796949-6
-	25.40	5	796949-5
-	20.32	4	796949-4
-	15.24	3	796949-3
-	10.16	2	796949-2
MARKING	A	POSN	PART NUMBER

THIS DRAWING IS A CONTROLLED DOCUMENT.		DWN S.WELDON 22AUG2001	TE Connectivity	
DIMENSIONS: mm		CHK D.BIEVENOUR 22AUG2001		
TOLERANCES UNLESS OTHERWISE SPECIFIED:		APVD D.BIEVENOUR 22AUG2001		
0 PLC ±0 1 PLC ±.3 2 PLC ±.25 3 PLC ±0 4 PLC ±0 ANGLES ±2° FINISH		NAME PRODUCT SPEC APPLICATION SPEC WEIGHT		
MATERIAL		SIZE A2 CAGE CODE 00779 DRAWING NO C-796949		RESTRICTED TO
CUSTOMER DRAWING		SCALE 4:1		SHEET 1 OF 2 REV DI

THIS DRAWING IS UNPUBLISHED.      RELEASED FOR PUBLICATION      20  
 © COPYRIGHT 20      ALL RIGHTS RESERVED.

LOC	DIST	REVISIONS				
P	LTR	DESCRIPTION	DATE	DWN	APVD	
FT	0	-	SEE SHEET 1	-	-	

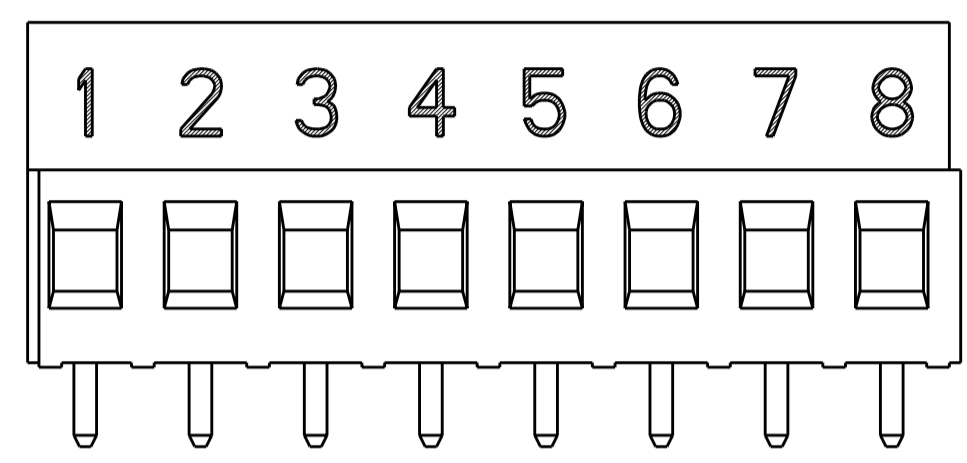

DETAIL L 

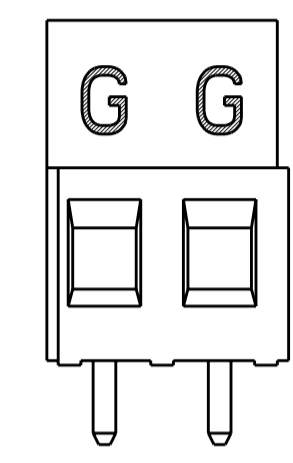

DETAIL N 

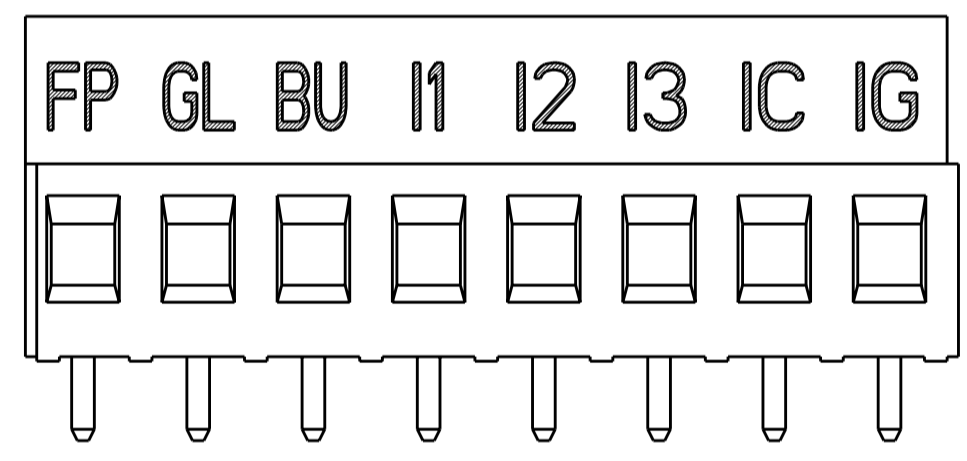

DETAIL M 

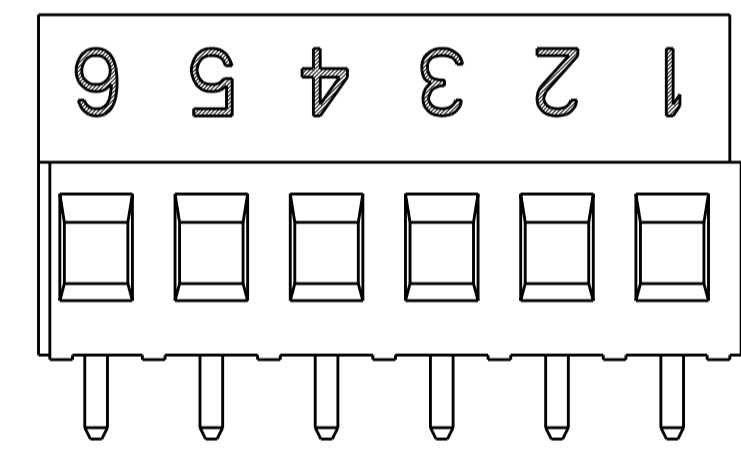

DETAIL P 

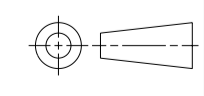
THIS DRAWING IS A CONTROLLED DOCUMENT.		DWN S. WELDON	22AUG2001	<b>STE</b> TE Connectivity
DIMENSIONS: mm		CHK D. BIEVENOUR	22AUG2001	
		APVD D. BIEVENOUR	22AUG2001	
		TOLERANCES UNLESS OTHERWISE SPECIFIED: 0 PLC ±0 1 PLC ±.3 2 PLC ±.25 3 PLC ±0 4 PLC ±0 ANGLES ±2° FINISH		
MATERIAL	-	PRODUCT SPEC	-	NAME TERMINAL BLOCK PCB MOUNT W/INTERLOCK, 5.08mm PITCH
		APPLICATION SPEC	-	SIZE A200779
		WEIGHT	-	CAGE CODE C-796949
		CUSTOMER DRAWING	SCALE 4:1	DRAWING NO 796949
			SHEET 2 OF 2	RESTRICTED TO -
			REV D1	