



Chipsmall Limited consists of a professional team with an average of over 10 year of expertise in the distribution of electronic components. Based in Hongkong, we have already established firm and mutual-benefit business relationships with customers from,Europe,America and south Asia,supplying obsolete and hard-to-find components to meet their specific needs.

With the principle of "Quality Parts,Customers Priority,Honest Operation,and Considerate Service",our business mainly focus on the distribution of electronic components. Line cards we deal with include Microchip,ALPS,ROHM,Xilinx,Pulse,ON,Everlight and Freescale. Main products comprise IC,Modules,Potentiometer,IC Socket,Relay,Connector.Our parts cover such applications as commercial,industrial, and automotives areas.

We are looking forward to setting up business relationship with you and hope to provide you with the best service and solution. Let us make a better world for our industry!



## Contact us

Tel: +86-755-8981 8866 Fax: +86-755-8427 6832

Email & Skype: info@chipsmall.com Web: www.chipsmall.com

Address: A1208, Overseas Decoration Building, #122 Zhenhua RD., Futian, Shenzhen, China



**Extraction Tools 91047-[ ]**

Figure 1

**1. INTRODUCTION**

Extraction Tools 91047-[ ] are designed to extract flexible flat cable (FFC) contacts from FFC pin, receptacle, and edge connectors with end entrance locking lance slots (reference part number 86670-8). Read these instructions thoroughly before removing any contacts.

For connectors with side entrance locking lance slots, refer to 408-7916 for Tool 91200-[ ].

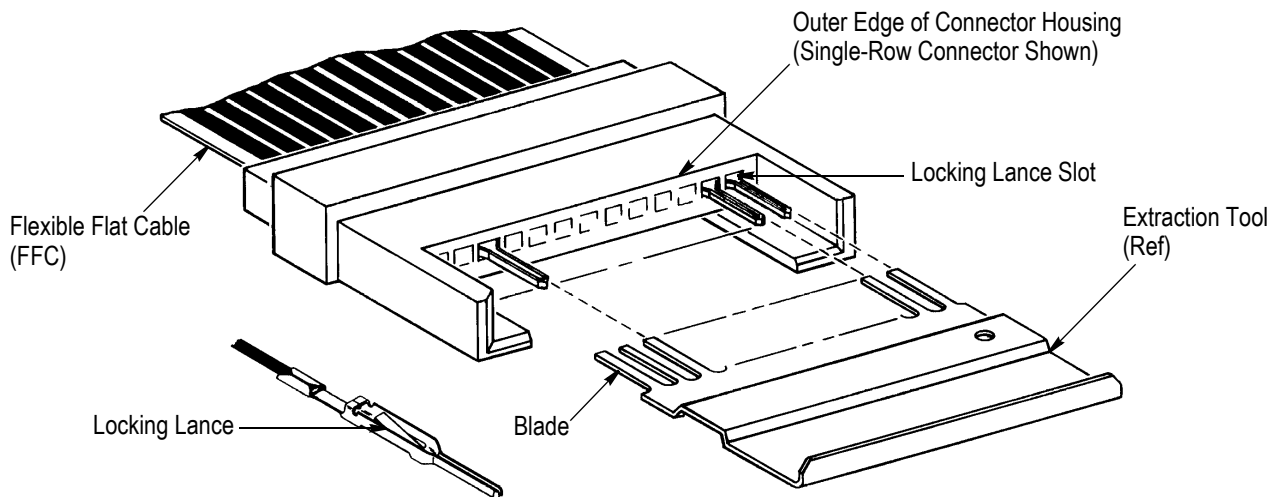

*Dimensions in this instruction sheet are in millimeters [with inches in brackets]. Figures are not drawn to scale.*

Reasons for reissue of this instruction sheet are provided in Section 6, REVISION SUMMARY.

**2. DESCRIPTION**

Each tool features a specific number of tool blades that release the contact locking lances of the connector. See Figure 1. The number of tool blades must match the number of cavities in one row of the connector.



*All contact locking lances must be released simultaneously; otherwise, damage to the connector, contacts, or cable may result.*

**3. EXTRACTION PROCEDURE**

Refer to Figure 2, and ensure that the number of blades of the extraction tool matches the number of contact cavities in one row of the connector.

EXTRACTION TOOL	
PART NUMBER	NUMBER OF BLADES
91047-1	9
91047-2	19
91047-3	29
91047-5	20
1-91047-0	10
1-91047-2	35
1-91047-4	12
1-91047-5	14
1-91047-6	15
1-91047-8	5
1-91047-9	3
2-91047-6	6

Figure 2

Proceed as follows:

1. Align the tool blades with the locking lance slots located between the contacts and outer edge of the housing as shown in Figure 1.
2. Simultaneously insert all tool blades straight into the connector until the tool bottoms. Only the radius between the tool blades should be visible when the tool is properly seated. See Figure 3.
3. Holding the tool and connector in one hand, carefully pull on the cable. A slight side-to-side motion may be used to ease contact extraction.

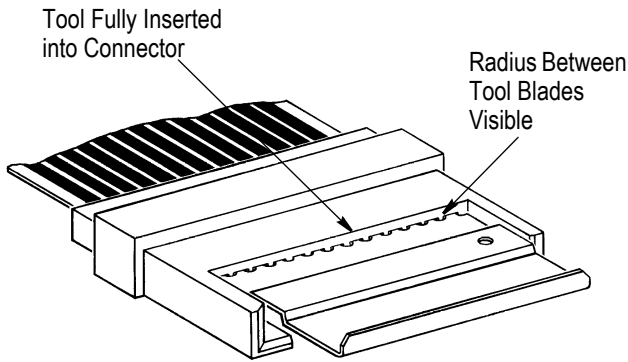

Figure 3



Excessive or improper force may cause damage to the contacts or cable.

4. After the cable and all of the contacts have been completely extracted, remove the tool from the connector.

**4. MAINTENANCE AND INSPECTION**

To ensure proper operation, the tool should conform to the dimensions provided in Figure 4.

It is recommended that the tool be inspected immediately when received and at regularly scheduled intervals.

It is recommended that the tool be stored in a clean, dry place and cleaned with a soft, lint-free cloth.

**5. REPLACEMENT AND REPAIR**

The tool is not repairable and should be replaced when worn or damaged. Additional tools can be purchased from:

CUSTOMER SERVICE (038-035)  
 TYCO ELECTRONICS CORPORATION  
 PO BOX 3608  
 HARRISBURG PA 17105-3608

**6. REVISION SUMMARY**

Revisions to this instruction sheet include:

- Updated instruction sheet to corporate requirements
- Removed obsolete extraction tools
- Replaced connector series part numbers with reference part number

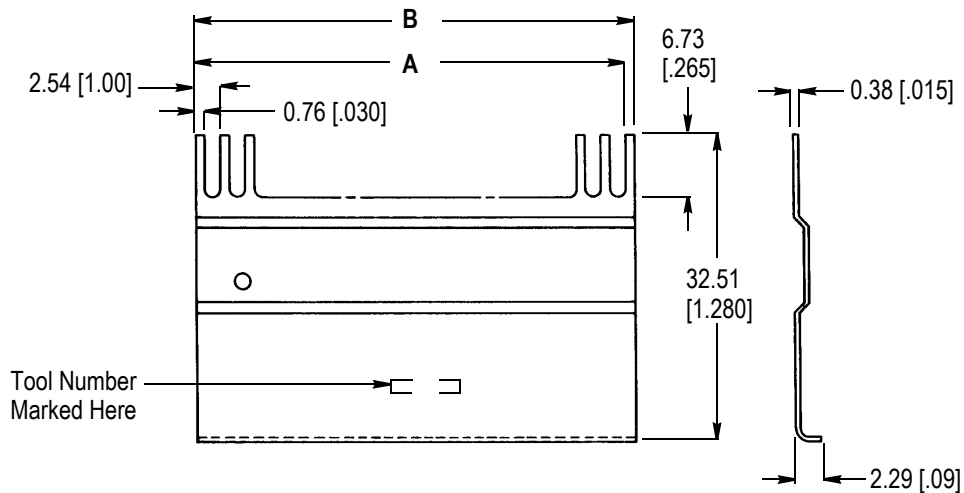

**EXTRACTION TOOL**

PART NUMBER	DIMENSION		PART NUMBER	DIMENSION	
	A	B		A	B
91047-1	20.32 [1.800]	21.08 [1.830]	1-91047-4	27.94 [1.100]	28.70 [1.130]
91047-2	45.72 [1.800]	46.48 [1.830]	1-91047-5	33.02 [1.300]	33.78 [1.330]
91047-3	71.12 [2.800]	71.88 [2.830]	1-91047-6	35.56 [1.400]	36.32 [1.430]
91047-5	48.26 [1.900]	49.02 [1.930]	1-91047-8	10.16 [1.400]	10.92 [1.430]
1-91047-0	22.86 [1.900]	23.62 [1.930]	1-91047-9	5.08 [1.200]	5.84 [1.230]
1-91047-2	86.36 [3.400]	87.12 [3.430]	2-91047-6	17.78 [1.700]	18.54 [1.730]

Figure 4