



Chipsmall Limited consists of a professional team with an average of over 10 year of expertise in the distribution of electronic components. Based in Hongkong, we have already established firm and mutual-benefit business relationships with customers from,Europe,America and south Asia,supplying obsolete and hard-to-find components to meet their specific needs.

With the principle of "Quality Parts,Customers Priority,Honest Operation,and Considerate Service",our business mainly focus on the distribution of electronic components. Line cards we deal with include Microchip,ALPS,ROHM,Xilinx,Pulse,ON,Everlight and Freescale. Main products comprise IC,Modules,Potentiometer,IC Socket,Relay,Connector.Our parts cover such applications as commercial,industrial, and automotives areas.

We are looking forward to setting up business relationship with you and hope to provide you with the best service and solution. Let us make a better world for our industry!



Contact us

Tel: +86-755-8981 8866 Fax: +86-755-8427 6832

Email & Skype: info@chipsmall.com Web: www.chipsmall.com

Address: A1208, Overseas Decoration Building, #122 Zhenhua RD., Futian, Shenzhen, China



Flanged Resistor 10 Watts, 100Ω



General Specifications

Resistive Element	Thick film
Substrate	Alumina Ceramic
Cover	Copper, Nickel plated per QQ-N-290
Mounting Flange	Beryllium oxide ceramic
Lead(s):	99.99% pure Silver (.005" thk)

Features:

- DC – 6.0 GHz
- 10 Watts
- BeO Ceramic
- Non-Nichrome Resistive Element
- Low VSWR
- 100% Tested

Electrical Specifications

Resistance Range:	100 ohms, $\pm 5\%$
Frequency Range;	DC – 6.0 GHz
Power:	10 Watts
Capacitance:	0.75 pF Typical

Note: Tolerance is $\pm 0.010"$, unless otherwise specified. Designed to meet or exceed applicable portions of MIL-E-5400. Operating temperature is -55°C to 150°C (see chart for derating temperatures).

All dimensions in inches.

Specifications subject to change without notice.

Outline Drawing

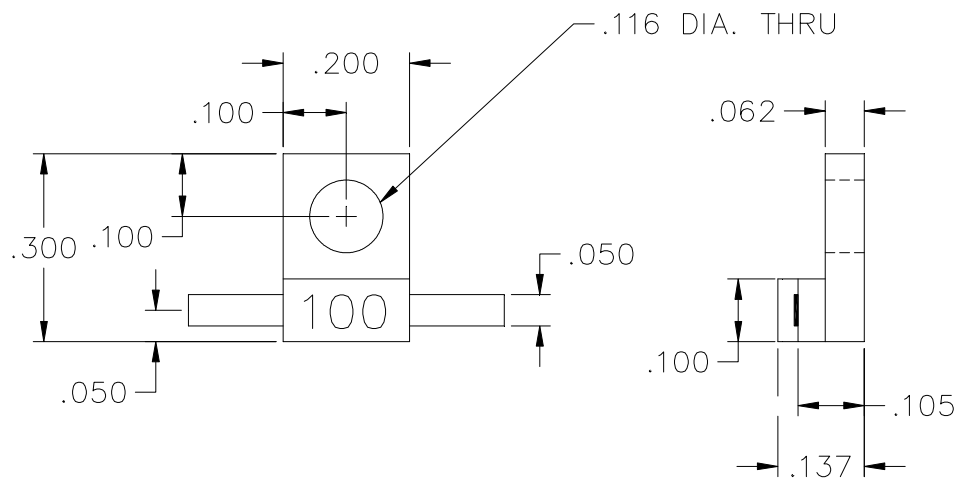

10-100RV (097) Rev D

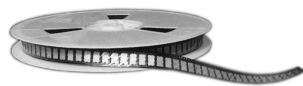



Typical Performance:

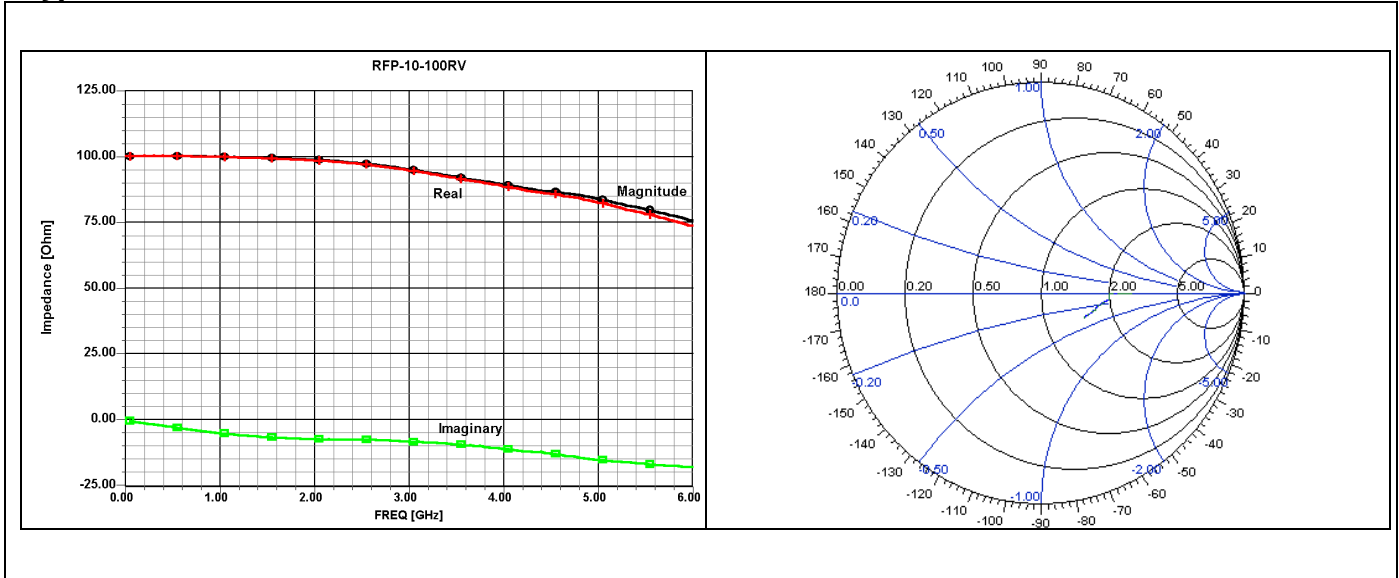

Power De-rating:

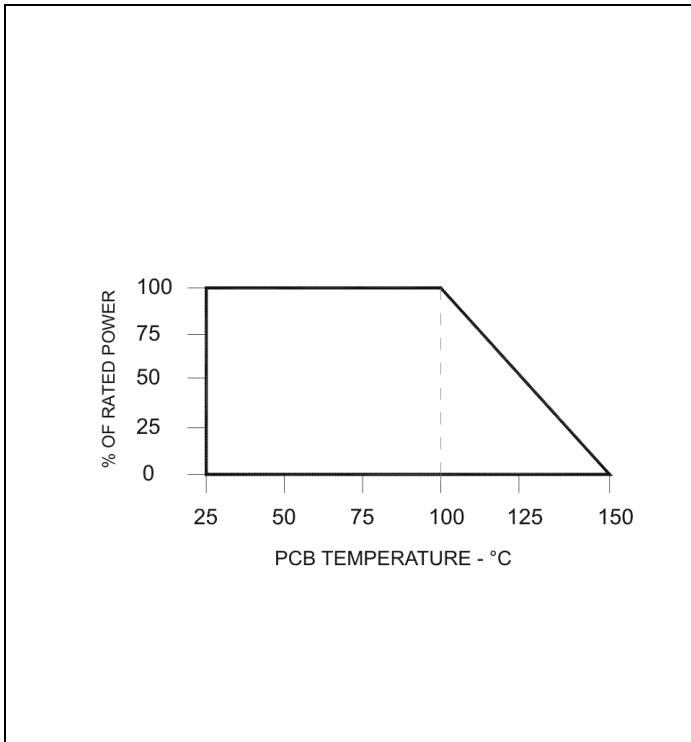

Mounting Footprint and Procedure:

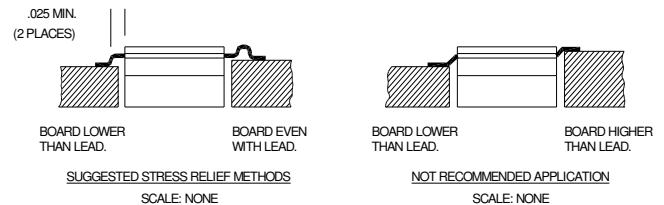

SUGGESTED MOUNTING PROCEDURES:

1. MAKE SURE THAT THE DEVICES ARE MOUNTED ON FLAT SURFACES (.001" UNDER THE DEVICE) TO OPTIMIZE THE HEAT TRANSFER.
2. DRILL & TAP THE HEATSINK FOR THE APPROPRIATE THREAD SIZE TO BE USED.
3. COAT HEATSINK WITH A MINIMUM AMOUNT OF HIGH QUALITY SILICONE GREASE (.001" MAX. THICKNESS).
4. POSITION DEVICE ON MOUNTING SURFACE & SECURE USING SOCKET HEAD SCREWS, FLAT & SPLIT WASHER. TORQUE SCREWS TO THE APPROPRIATE VALUE. MAKE SURE THAT THE DEVICE IS FLAT AGAINST THE HEATSINK. (CARE SHOULD BE TAKEN TO AVOID UPWARD PRESSURE OF THE LEADS TOWARDS THE LID).
5. SOLDER LEADS IN PLACE USING APPROPRIATE SOLDER WITH A CONTROLLED TEMPERATURE IRON.

** FOR MORE DETAILS CONTACT FACTORY **

10-100RV (097) Rev D

USA/Canada: (315) 432-8909
Toll Free: (800) 544-2414
Europe: +44 2392-232392

Available on Tape and Reel For Pick and Place Manufacturing.

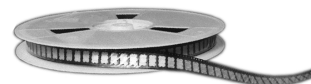

Anaren
What'll we think of next?™