



Chipsmall Limited consists of a professional team with an average of over 10 year of expertise in the distribution of electronic components. Based in Hongkong, we have already established firm and mutual-benefit business relationships with customers from,Europe,America and south Asia,supplying obsolete and hard-to-find components to meet their specific needs.

With the principle of “Quality Parts,Customers Priority,Honest Operation,and Considerate Service”,our business mainly focus on the distribution of electronic components. Line cards we deal with include Microchip,ALPS,ROHM,Xilinx,Pulse,ON,Everlight and Freescale. Main products comprise IC,Modules,Potentiometer,IC Socket,Relay,Connector.Our parts cover such applications as commercial,industrial, and automotives areas.

We are looking forward to setting up business relationship with you and hope to provide you with the best service and solution. Let us make a better world for our industry!



Contact us

Tel: +86-755-8981 8866 Fax: +86-755-8427 6832

Email & Skype: info@chipsmall.com Web: www.chipsmall.com

Address: A1208, Overseas Decoration Building, #122 Zhenhua RD., Futian, Shenzhen, China



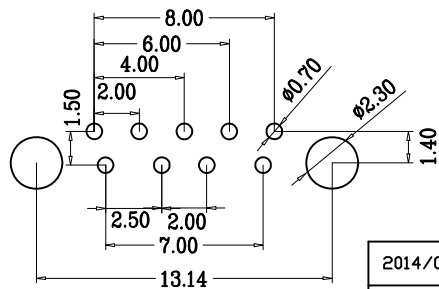
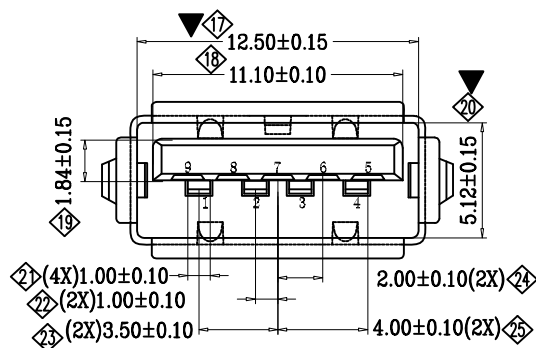
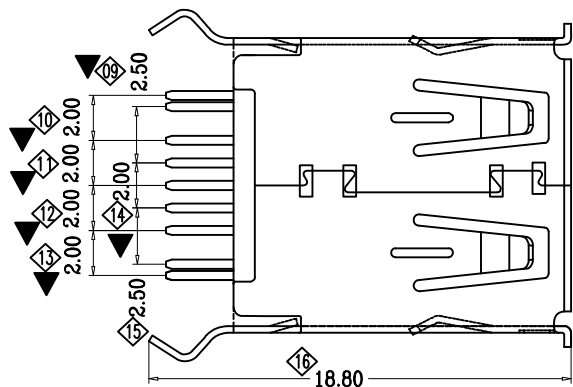
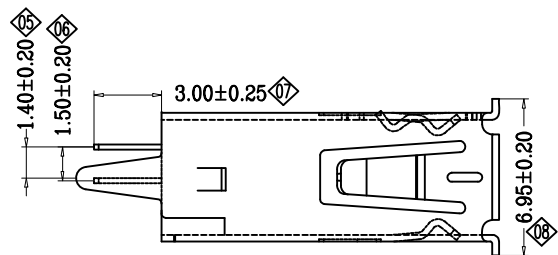
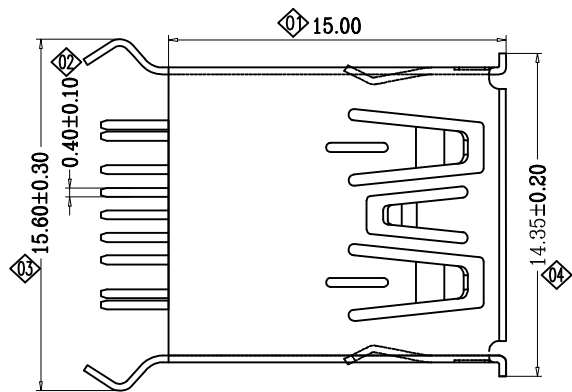

RECOMMENDED PCB LAYOUT
TOLERANCE: ±0.05mm

NOTE:

1. MATERIAL:

- 1.1 INSULATOR:PBT UL 94V-0
- 1.2 CONTACT:BRONZR (T=0.25mm)
- 1.3 SHELL:SPCC (T=0.30mm)
- 1.4 SHELL:BRASS (T=0.30mm)

2. ELECTRICAL CHARACTERISTICS:

- 2.1 CONTACTRESISTANCE:30mΩ MAXIMUM
- 2.2 CONTACT CURRENT RATING:1.5A
- 2.3 DIELECTRIC WITHSTANDING VOLTAGE:500 V R. M. S.
- 2.4 INSULATION RESISTANCE 1000 MEGOHMS MIN
- 2.5 OPERATING TEMPEROTURE:-40° C ~ 85° C

3 MECHANICAL CHARACTERISTICS:

- 3.1 MATING FORCE:3.57kg MAX
- 3.2 UNMATING FORCE:1.02kg MIN
- 3.3 DURABILITY:MANDATORY:5,000 CYCLES

4. PLATING

- 4.1 TERMINAL:GOLD FLASH ALL OVER 50u" MIN
NICKEL AND 1u"MIN Tin ALL OVER 50u" MIN NICKEL
ON SOLDER AREA
- 4.2 SHELL:150u"MIN.NICEL OVER 20"MIN COPPER

2014/06/06	Jody		Structural changes		A1
2012/03/06	XIE		NEW DWG		A0
DATE	DR.BY	ECN.NO.	DESCRIPTION	MARK	VER.
-TOLERANCES- UNLESS OTHERWISE SPECIFIED			CnC Tech, LLC		
			TITLE: USB 3.0 AF DIP 180度		
X.X	± 0.25	X.X°	± 3.00°	APPD:	PRODUCT NO: 1003-001-0100180
X.XX	± 0.20	X.XX°	± 1.00°	CHECK:	DATE
X.XXX	± 0.15	X.XXX°	± 0.500°	DRAW:	SCALE
			2016/04/06	1:1	mm
				UNIT	TYPE
				Z	1 / 1