



Chipsmall Limited consists of a professional team with an average of over 10 year of expertise in the distribution of electronic components. Based in Hongkong, we have already established firm and mutual-benefit business relationships with customers from,Europe,America and south Asia,supplying obsolete and hard-to-find components to meet their specific needs.

With the principle of “Quality Parts,Customers Priority,Honest Operation,and Considerate Service”,our business mainly focus on the distribution of electronic components. Line cards we deal with include Microchip,ALPS,ROHM,Xilinx,Pulse,ON,Everlight and Freescale. Main products comprise IC,Modules,Potentiometer,IC Socket,Relay,Connector.Our parts cover such applications as commercial,industrial, and automotives areas.

We are looking forward to setting up business relationship with you and hope to provide you with the best service and solution. Let us make a better world for our industry!



## Contact us

Tel: +86-755-8981 8866 Fax: +86-755-8427 6832

Email & Skype: info@chipsmall.com Web: www.chipsmall.com

Address: A1208, Overseas Decoration Building, #122 Zhenhua RD., Futian, Shenzhen, China



# 100331 Low Power Triple D-Type Flip-Flop

## General Description

The 100331 contains three D-type, edge-triggered master/slave flip-flops with true and complement outputs, a Common Clock (CP<sub>C</sub>), and Master Set (MS) and Master Reset (MR) inputs. Each flip-flop has individual Clock (CP<sub>n</sub>), Direct Set (SD<sub>n</sub>) and Direct Clear (CD<sub>n</sub>) inputs. Data enters a master when both CP<sub>n</sub> and CP<sub>C</sub> are LOW and transfers to a slave when CP<sub>n</sub> or CP<sub>C</sub> (or both) go HIGH. The Master Set, Master Reset and individual CD<sub>n</sub> and SD<sub>n</sub> inputs override the Clock inputs. All inputs have 50 kΩ pull-down resistors.

## Features

- 35% power reduction of the 100131
- 2000V ESD protection
- Pin/function compatible with 100131
- Voltage compensated operating range = -4.2V to -5.7V
- Available to industrial grade temperature range

## Ordering Code:

Order Number	Package Number	Package Description
100331SC	M24B	24-Lead Small Outline Integrated Circuit (SOIC), JEDEC MS-013, 0.300 Wide
100331PC	N24E	24-Lead Plastic Dual-In-Line Package (PDIP), JEDEC MS-010, 0.400 Wide
100331QC	V28A	28-Lead Plastic Lead Chip Carrier (PLCC), JEDEC MO-047, 0.450 Square
100331QI	V28A	28-Lead Plastic Lead Chip Carrier (PLCC), JEDEC MO-047, 0.450 Square Industrial Temperature Range (-40°C to +85°C)

Devices also available in Tape and Reel. Specify by appending the suffix letter "X" to the ordering code.

## Logic Symbol

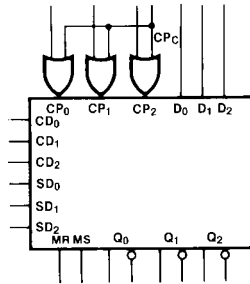

## Connection Diagrams

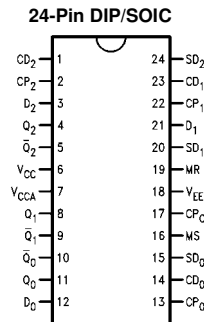

## Pin Descriptions

Pin Names	Description
CP <sub>0</sub> -CP <sub>2</sub>	Individual Clock Inputs
CP <sub>C</sub>	Common Clock Input
D <sub>0</sub> -D <sub>2</sub>	Data Inputs
CD <sub>0</sub> -CD <sub>2</sub>	Individual Direct Clear Inputs
SD <sub>n</sub>	Individual Direct Set Inputs
MR	Master Reset Input
MS	Master Set Input
Q <sub>0</sub> -Q <sub>2</sub>	Data Outputs
Q <sub>0</sub> -Q <sub>2</sub> (bar)	Complementary Data Outputs

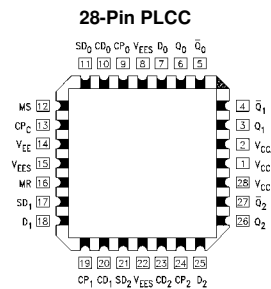

## Truth Tables

**Synchronous Operation** (Each Flip-Flop)

Inputs					Outputs
D <sub>n</sub>	CP <sub>n</sub>	CP <sub>C</sub>	MS SD <sub>n</sub>	MR CD <sub>n</sub>	Q <sub>n</sub> (t + 1)
L	↗	L	L	L	L
H	↗	L	L	L	H
L	L	↗	L	L	L
H	L	↗	L	L	H
X	L	L	L	L	Q <sub>n</sub> (t)
X	H	X	L	L	Q <sub>n</sub> (t)
X	X	H	L	L	Q <sub>n</sub> (t)

**Asynchronous Operation** (Each Flip-Flop)

Inputs					Outputs
D <sub>n</sub>	CP <sub>n</sub>	CP <sub>C</sub>	MS SD <sub>n</sub>	MR CD <sub>n</sub>	Q <sub>n</sub> (t + 1)
X	X	X	H	L	H
X	X	X	L	H	L
X	X	X	H	H	U

H = HIGH Voltage Level  
 L = LOW Voltage Level  
 X = Don't Care  
 U = Undefined  
 t = Time before CP Positive Transition  
 t + 1 = Time after CP Positive Transition  
 ↗ = LOW-to-HIGH Transition

## Logic Diagram

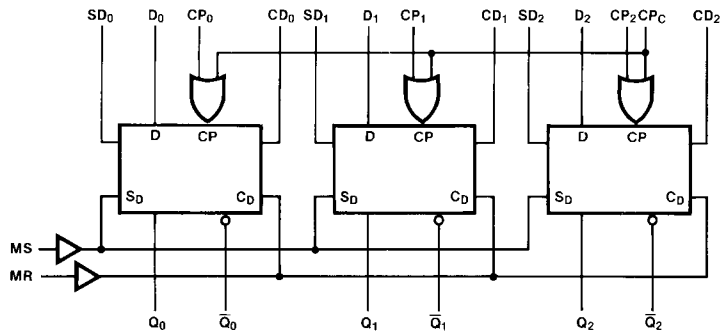

**Absolute Maximum Ratings**(Note 1)

Storage Temperature ( $T_{STG}$ )	-65°C to +150°C
Maximum Junction Temperature ( $T_J$ )	+150°C
Pin Potential to Ground Pin ( $V_{EE}$ )	-7.0V to +0.5V
Input Voltage (DC)	$V_{EE}$ to +0.5V
Output Current (DC Output HIGH)	-50 mA
ESD (Note 2)	≤ 2000V

**Recommended Operating Conditions**

Case Temperature ( $T_C$ )	Commercial	0°C to +85°C
	Industrial	-40°C to +85°C
Supply Voltage ( $V_{EE}$ )		-5.7V to -4.2V

**Note 1:** The "Absolute Maximum Ratings" are those values beyond which the safety of the device cannot be guaranteed. The device should not be operated at these limits. The parametric values defined in the Electrical Characteristics tables are not guaranteed at the absolute maximum rating. The "Recommended Operating Conditions" table will define the conditions for actual device operation.

**Note 2:** ESD testing conforms to MIL-STD-883, Method 3015.

**Commercial Version****DC Electrical Characteristics** (Note 3)

$V_{EE} = -4.2V$  to  $-5.7V$ ,  $V_{CC} = V_{CCA} = GND$ ,  $T_C = 0^\circ C$  to  $+85^\circ C$

Symbol	Parameter	Min	Typ	Max	Units	Conditions	
$V_{OH}$	Output HIGH Voltage	-1025	-955	-870	mV	$V_{IN} = V_{IH}$ (Max) or $V_{IL}$ (Min)	Loading with 50Ω to -2.0V
$V_{OL}$	Output LOW Voltage	-1830	-1705	-1620	mV		
$V_{OHC}$	Output HIGH Voltage	-1035			mV	$V_{IN} = V_{IH}$ (Min) or $V_{IL}$ (Max)	Loading with 50Ω to -2.0V
$V_{OLC}$	Output LOW Voltage			-1610	mV		
$V_{IH}$	Input HIGH Voltage	-1165		-870	mV	Guaranteed HIGH Signal for All Inputs	
$V_{IL}$	Input LOW Voltage	-1830		-1475	mV	Guaranteed LOW Signal for All Inputs	
$I_{IL}$	Input LOW Current	0.5			μA	$V_{IN} = V_{IL}$ (Min)	
$I_{IH}$	Input HIGH Current			240	μA	$V_{IN} = V_{IH}$ (Max)	
$I_{EE}$	Power Supply Current	-122		-65	mA	Inputs OPEN	

**Note 3:** The specified limits represent the "worst case" value for the parameter. Since these values normally occur at the temperature extremes, additional noise immunity and guardbanding can be achieved by decreasing the allowable system operating ranges. Conditions for testing shown in the tables are chosen to guarantee operation under "worst case" conditions.

**Commercial Version** (Continued)  
**DIP AC Electrical Characteristics**
 $V_{EE} = -4.2V$  to  $-5.7V$ ,  $V_{CC} = V_{CCA} = GND$ 

Symbol	Parameter	$T_C = 0^\circ C$		$T_C = +25^\circ C$		$T_C = +85^\circ C$		Units	Conditions
		Min	Max	Min	Max	Min	Max		
$f_{MAX}$	Toggle Frequency	375		375		375		MHz	Figures 2, 3
$t_{PLH}$ $t_{PHL}$	Propagation Delay CP <sub>C</sub> to Output	0.75	2.00	0.75	2.00	0.75	2.00	ns	Figures 1, 3
$t_{PLH}$ $t_{PHL}$	Propagation Delay CP <sub>n</sub> to Output	0.75	2.00	0.75	2.00	0.75	2.00	ns	
$t_{PLH}$ $t_{PHL}$	Propagation Delay CD <sub>n</sub> , SD <sub>n</sub> to Output	0.70	1.70	0.70	1.70	0.70	1.80	ns	Figures 1, 4
$t_{PLH}$ $t_{PHL}$		0.70	2.00	0.70	2.00	0.70	2.00		
$t_{PLH}$ $t_{PHL}$	Propagation Delay MS, MR to Output	1.10	2.60	1.10	2.60	1.10	2.60	ns	
$t_{PLH}$ $t_{PHL}$		1.10	2.80	1.10	2.80	1.10	2.80		
$t_{TLH}$ $t_{THL}$	Transition Time 20% to 80%, 80% to 20%	0.35	1.30	0.35	1.30	0.35	1.30	ns	Figures 1, 3, 4
$t_S$	Setup Time							ns	Figure 5
	D <sub>n</sub>	0.40		0.40		0.40			Figure 4
	CD <sub>n</sub> , SD <sub>n</sub> (Release Time) MS, MR (Release Time)	1.30 2.30		1.30 2.30		1.30 2.30			
$t_H$	Hold Time D <sub>n</sub>	0.5		0.5		0.7		ns	Figure 5
$t_{PW(H)}$	Pulse Width HIGH CP <sub>n</sub> , CP <sub>C</sub> , CD <sub>n</sub> , SD <sub>n</sub> , MR, MS	2.00		2.00		2.00		ns	Figures 3, 4

**SOIC and PLCC AC Electrical Characteristics**
 $V_{EE} = -4.2V$  to  $-5.7V$ ,  $V_{CC} = V_{CCA} = GND$ 

Symbol	Parameter	$T_C = 0^\circ C$		$T_C = +25^\circ C$		$T_C = +85^\circ C$		Units	Conditions
		Min	Max	Min	Max	Min	Max		
$f_{MAX}$	Toggle Frequency	400		400		400		MHz	Figures 2, 3
$t_{PLH}$ $t_{PHL}$	Propagation Delay CP <sub>C</sub> to Output	0.75	1.80	0.75	1.80	0.75	1.80	ns	Figures 1, 3
$t_{PLH}$ $t_{PHL}$	Propagation Delay CP <sub>n</sub> to Output	0.75	1.80	0.75	1.80	0.75	1.80	ns	
$t_{PLH}$ $t_{PHL}$	Propagation Delay CD <sub>n</sub> , SD <sub>n</sub> to Output	0.70	1.50	0.70	1.50	0.70	1.60	ns	Figures 1, 4
$t_{PLH}$ $t_{PHL}$		0.80	1.80	0.70	1.80	0.70	1.80		
$t_{PLH}$ $t_{PHL}$	Propagation Delay MS, MR to Output	1.10	2.40	1.10	2.40	1.10	2.40	ns	
$t_{PLH}$ $t_{PHL}$		1.10	2.60	1.10	2.60	1.10	2.60		
$t_{TLH}$ $t_{THL}$	Transition Time 20% to 80%, 80% to 20%	0.35	1.10	0.35	1.10	0.35	1.10	ns	Figures 1, 3, 4
$t_S$	Setup Time							ns	Figure 5
	D <sub>n</sub>	0.30		0.30		0.30			Figure 4
	CD <sub>n</sub> , SD <sub>n</sub> (Release Time) MS, MR (Release Time)	1.20 2.20		1.20 2.20		1.20 2.20			
$t_H$	Hold Time D <sub>n</sub>	0.5		0.5		0.7		ns	Figure 5
$t_{PW(H)}$	Pulse Width HIGH CP <sub>n</sub> , CP <sub>C</sub> , CD <sub>n</sub> , SD <sub>n</sub> , MR, MS	2.00		2.00		2.00		ns	Figures 3, 4

Commercial Version (Continued)										
Symbol	Parameter	T <sub>C</sub> = 0°C		T <sub>C</sub> = +25°C		T <sub>C</sub> = +85°C		Units	Conditions	
		Min	Max	Min	Max	Min	Max			
t <sub>PLH</sub> t <sub>PHL</sub>	Propagation Delay CP <sub>n</sub> to Output	0.75	1.40	0.75	1.40	0.80	1.50	ns	Figures 1, 3 PLCC Only	
t <sub>PLH</sub> t <sub>PHL</sub>	Propagation Delay CP <sub>n</sub> to Output	0.70	1.40	0.75	1.40	0.80	1.50	ns		
t <sub>PLH</sub> t <sub>PHL</sub>	Propagation Delay CD <sub>n</sub> , SD <sub>n</sub> to Output	0.70	1.50	0.70	1.50	0.80	1.60	ns	CP <sub>n</sub> , CP <sub>C</sub> = L PLCC Only	Figures 1, 4
t <sub>PLH</sub> t <sub>PHL</sub>		0.80	1.70	0.80	1.70	0.80	1.80			
t <sub>PLH</sub> t <sub>PHL</sub>	Propagation Delay MS, MR to Output	1.10	2.00	1.10	2.00	1.20	2.10	ns	CP <sub>n</sub> , CP <sub>C</sub> = L PLCC Only	
t <sub>PLH</sub> t <sub>PHL</sub>		1.20	2.10	1.20	2.10	1.30	2.20		CP <sub>n</sub> , CP <sub>C</sub> = H PLCC Only	
t <sub>OSSL</sub>	Maximum Skew Common Edge Output-to-Output Variation Common Clock to Output Path	100		100		100		ps	PLCC Only (Note 4)	
t <sub>OSSL</sub>	Maximum Skew Common Edge Output-to-Output Variation CP <sub>n</sub> to Output Path	235		235		235		ps	PLCC Only (Note 4)	
t <sub>OSLH</sub>	Maximum Skew Common Edge Output-to-Output Variation Common Clock to Output Path	120		120		120		ps	PLCC Only (Note 4)	
t <sub>OSLH</sub>	Maximum Skew Common Edge Output-to-Output Variation CP <sub>n</sub> to Output Path	275		275		275		ps	PLCC Only (Note 4)	
t <sub>OST</sub>	Maximum Skew Opposite Edge Output-to-Output Variation Common Clock to Output Path	125		125		125		ps	PLCC Only (Note 4)	
t <sub>OST</sub>	Maximum Skew Opposite Edge Output-to-Output Variation CP <sub>n</sub> to Output Path	265		265		265		ps	PLCC Only (Note 4)	
t <sub>PS</sub>	Maximum Skew Pin (Signal) Transition Variation Common Clock to Output Path	90		90		90		ps	PLCC Only (Note 4)	
t <sub>PS</sub>	Maximum Skew Pin (Signal) Transition Variation CP <sub>n</sub> to Output Path	90		90		90		ps	PLCC Only (Note 4)	

**Note 4:** Output-to-Output Skew is defined as the absolute value of the difference between the actual propagation delay for any outputs within the same packaged device. The specifications apply to any outputs switching in the same direction either HIGH-to-LOW (t<sub>OSSL</sub>), or LOW-to-HIGH (t<sub>OSLH</sub>), or in opposite directions both HL and LH (t<sub>OST</sub>). Parameters t<sub>OST</sub> and t<sub>PS</sub> guaranteed by design.

## Industrial Version

## PLCC DC Electrical Characteristics (Note 5)

 $V_{EE} = -4.2V$  to  $-5.7V$ ,  $V_{CC} = V_{CCA} = GND$ ,  $T_C = -40^\circ C$  to  $+85^\circ C$ 

Symbol	Parameter	$T_C = -40^\circ C$		$T_C = 0^\circ C$ to $+85^\circ C$		Units	Conditions	
		Min	Max	Min	Max			
$V_{OH}$	Output HIGH Voltage	-1085	-870	-1025	-870	mV	$V_{IN} = V_{IH}$ (Max)	Loading with 50 $\Omega$ to -2.0V
$V_{OL}$	Output LOW Voltage	-1830	-1575	-1830	-1620	mV	or $V_{IL}$ (Min)	
$V_{OHC}$	Output HIGH Voltage	-1095		-1035		mV	$V_{IN} = V_{IH}$ (Min)	Loading with 50 $\Omega$ to -2.0V
$V_{OLC}$	Output LOW Voltage		-1565		-1610	mV	or $V_{IL}$ (Max)	
$V_{IH}$	Input HIGH Voltage	-1170	-870	-1165	-870	mV	Guaranteed HIGH Signal for All Inputs	
$V_{IL}$	Input LOW Voltage	-1830	-1480	-1830	1475	mV	Guaranteed LOW Signal for All Inputs	
$I_{IL}$	Input LOW Current	0.5		0.5		$\mu A$	$V_{IN} = V_{IL}$ (Min)	
$I_{IH}$	Input HIGH Current		300		240	$\mu A$	$V_{IN} = V_{IH}$ (Max)	
$I_{EE}$	Power Supply Current	-122	-60	-122	-65	mA	Inputs Open	

**Note 5:** The specified limits represent the "worst case" value for the parameter. Since these values normally occur at the temperature extremes, additional noise immunity and guardbanding can be achieved by decreasing the allowable system operating ranges. Conditions for testing shown in the tables are chosen to guarantee operation under "worst case" conditions.

## PLCC AC Electrical Characteristics

 $V_{EE} = -4.2V$  to  $-5.7V$ ,  $V_{CC} = V_{CCA} = GND$ 

Symbol	Parameter	$T_C = -40^\circ C$		$T_C = +25^\circ C$		$T_C = +85^\circ C$		Units	Conditions	
		Min	Max	Min	Max	Min	Max			
$f_{MAX}$	Toggle Frequency	375		400		400		MHz	Figures 2, 3	
$t_{PLH}$	Propagation Delay $CP_C$ to Output	0.75	1.80	0.75	1.80	0.75	1.80	ns	Figures 1, 3	
$t_{PHL}$	Propagation Delay $CP_n$ to Output	0.70	1.80	0.75	1.80	0.75	1.80	ns		
$t_{PLH}$	Propagation Delay $CD_n, SD_n$ to Output	0.60	1.50	0.70	1.50	0.70	1.60	ns	$CP_n, CP_C = L$	Figures 1, 4
$t_{PHL}$		0.70	1.80	0.70	1.80	0.70	1.80			
$t_{PLH}$	Propagation Delay MS, MR to Output	1.10	2.40	1.10	2.40	1.10	2.40	ns	$CP_n, CP_C = L$	
$t_{PHL}$		1.10	2.60	1.10	2.60	1.10	2.60			
$t_{TLH}$	Transition Time 20% to 80%, 80% to 20%	0.20	1.40	0.35	1.10	0.35	1.10	ns	Figures 1, 3, 4	
$t_S$	Setup Time $D_n$	1.00		0.30		0.30		ns	Figure 5	
	$CD_n, SD_n$ (Release Time)	1.50		1.20		1.20			Figure 4	
	MS, MR (Release Time)	2.50		2.20		2.20				
$t_H$	Hold Time $D_n$	0.7		0.5		0.7		ns	Figure 5	
$t_{PW(H)}$	Pulse Width HIGH $CP_n, CP_C, CD_n,$ $SD_n, MR, MS$	2.00		2.00		2.00		ns	Figures 3, 4	

Test Circuits

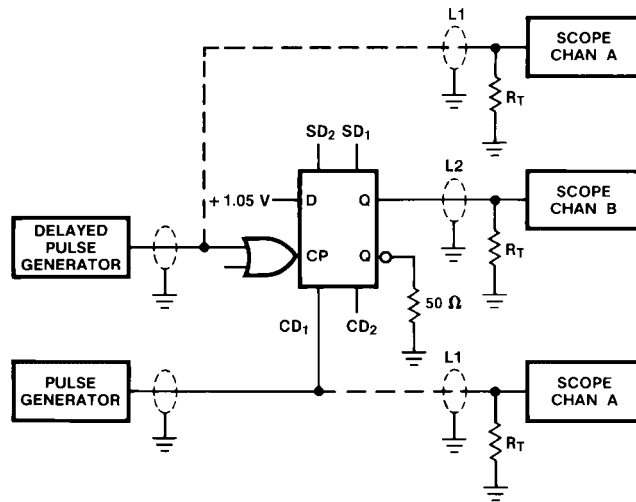
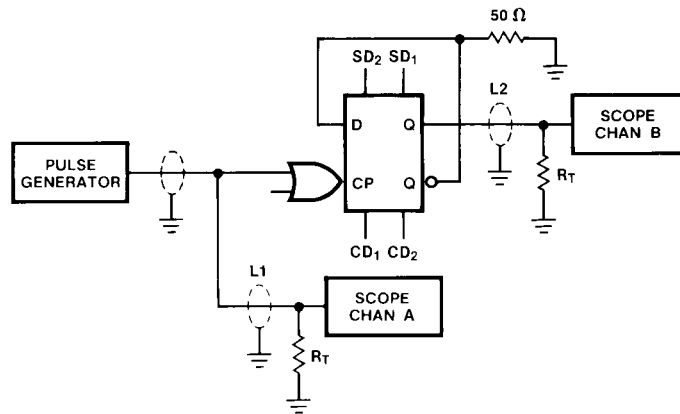

FIGURE 1. AC Test Circuit



Notes:

- $V_{CC}, V_{CCA} = +2V, V_{EE} = -2.5V$
- L1 and L2 = Equal length 50Ω impedance lines
- $R_T = 50\Omega$  terminator internal to scope
- Decoupling 0.1 μF from GND to  $V_{CC}$  and  $V_{EE}$
- All unused outputs are loaded with 50Ω to GND
- $C_L$  = Fixture and stray capacitance  $\leq 3$  pF

FIGURE 2. Toggle Frequency Test Circuit

## Switching Waveforms

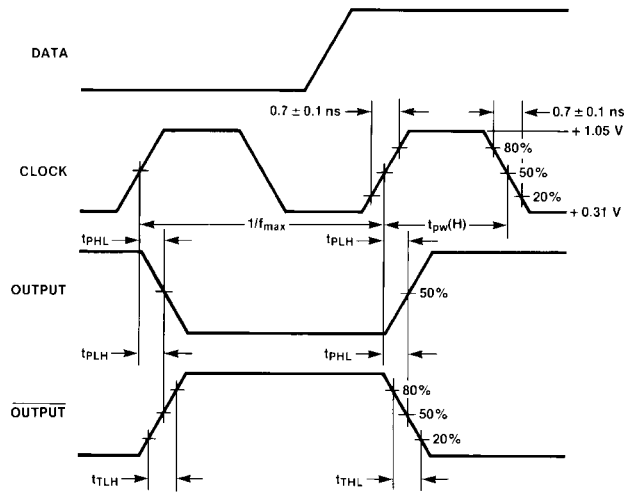

FIGURE 3. Propagation Delay (Clock) and Transition Times

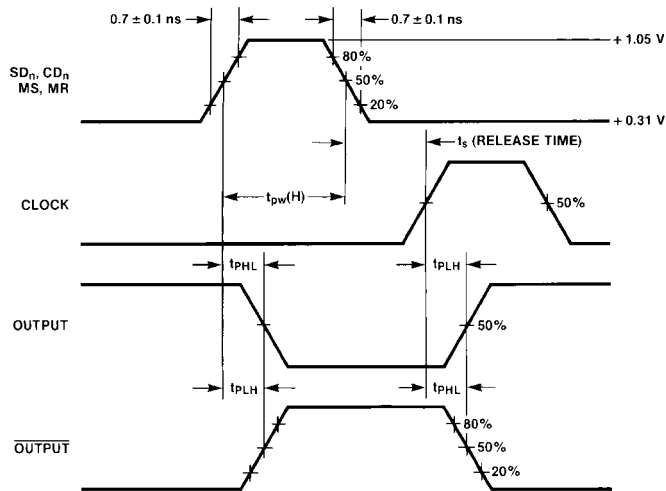

FIGURE 4. Propagation Delay (Resets)

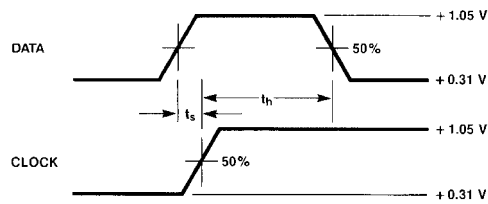

FIGURE 5. Data Setup and Hold Time

**Note:**

$t_s$  is the minimum time before the transition of the clock that information must be present at the data input.

$t_h$  is the minimum time after the transition of the clock that information must remain unchanged at the data input.

**Physical Dimensions** inches (millimeters) unless otherwise noted

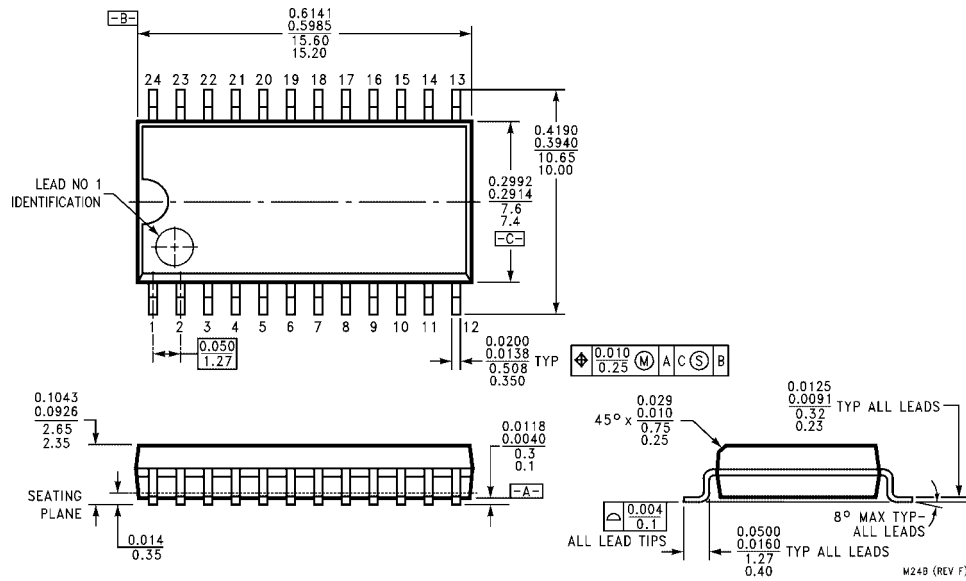

**24-Lead Small Outline Integrated Circuit (SOIC), JEDEC MS-013, 0.300 Wide  
Package Number M24B**

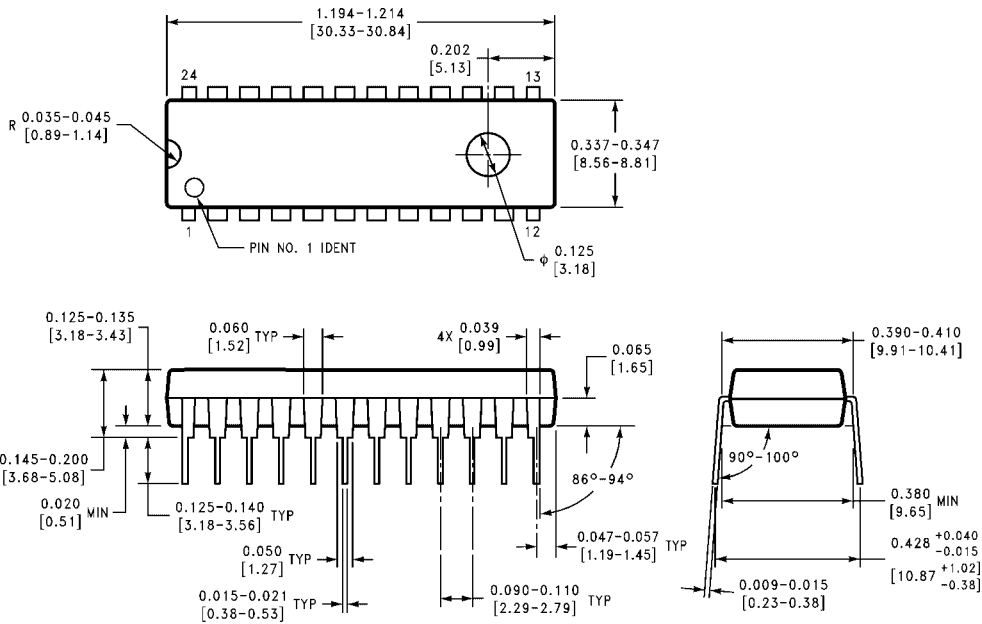

**24-Lead Plastic Dual-In-Line Package (PDIP), JEDEC MS-010, 0.400 Wide  
Package Number N24E**

**Physical Dimensions** inches (millimeters) unless otherwise noted (Continued)

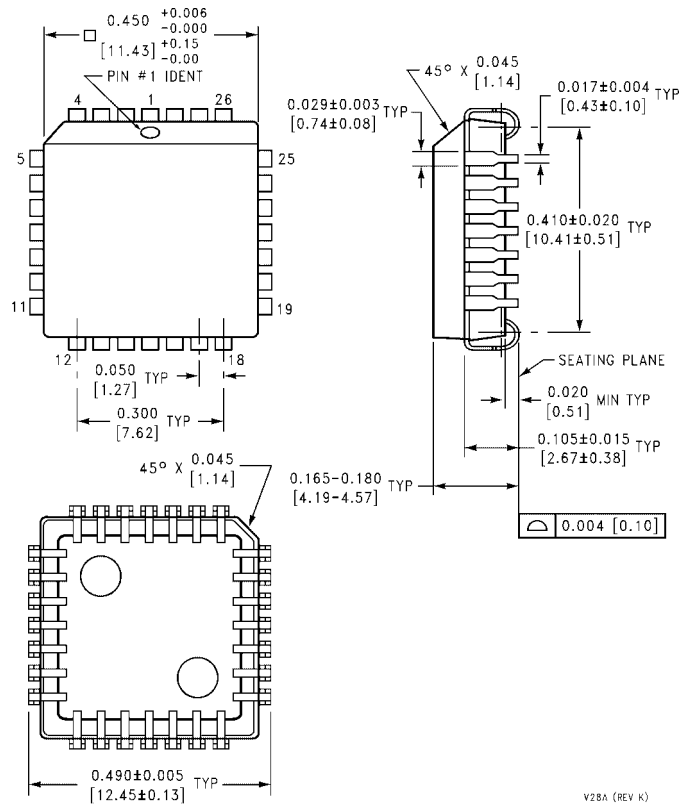

**28-Lead Plastic Lead Chip Carrier (PLCC), JEDEC MO-047, 0.450 Square Package Number V28A**

Fairchild does not assume any responsibility for use of any circuitry described, no circuit patent licenses are implied and Fairchild reserves the right at any time without notice to change said circuitry and specifications.

**LIFE SUPPORT POLICY**

FAIRCHILD'S PRODUCTS ARE NOT AUTHORIZED FOR USE AS CRITICAL COMPONENTS IN LIFE SUPPORT DEVICES OR SYSTEMS WITHOUT THE EXPRESS WRITTEN APPROVAL OF THE PRESIDENT OF FAIRCHILD SEMICONDUCTOR CORPORATION. As used herein:

1. Life support devices or systems are devices or systems which, (a) are intended for surgical implant into the body, or (b) support or sustain life, and (c) whose failure to perform when properly used in accordance with instructions for use provided in the labeling, can be reasonably expected to result in a significant injury to the user.
2. A critical component in any component of a life support device or system whose failure to perform can be reasonably expected to cause the failure of the life support device or system, or to affect its safety or effectiveness.

[www.fairchildsemi.com](http://www.fairchildsemi.com)