



Chipsmall Limited consists of a professional team with an average of over 10 year of expertise in the distribution of electronic components. Based in Hongkong, we have already established firm and mutual-benefit business relationships with customers from,Europe,America and south Asia,supplying obsolete and hard-to-find components to meet their specific needs.

With the principle of “Quality Parts,Customers Priority,Honest Operation,and Considerate Service”,our business mainly focus on the distribution of electronic components. Line cards we deal with include Microchip,ALPS,ROHM,Xilinx,Pulse,ON,Everlight and Freescale. Main products comprise IC,Modules,Potentiometer,IC Socket,Relay,Connector.Our parts cover such applications as commercial,industrial, and automotives areas.

We are looking forward to setting up business relationship with you and hope to provide you with the best service and solution. Let us make a better world for our industry!



## Contact us

Tel: +86-755-8981 8866 Fax: +86-755-8427 6832

Email & Skype: info@chipsmall.com Web: www.chipsmall.com

Address: A1208, Overseas Decoration Building, #122 Zhenhua RD., Futian, Shenzhen, China



PRODUCT NO.  
 10041724-001LF  
 10041724-002LF

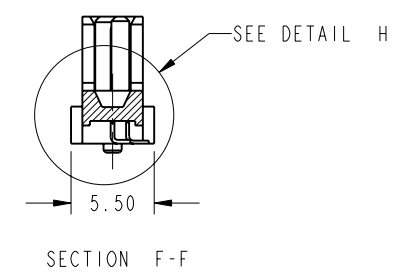
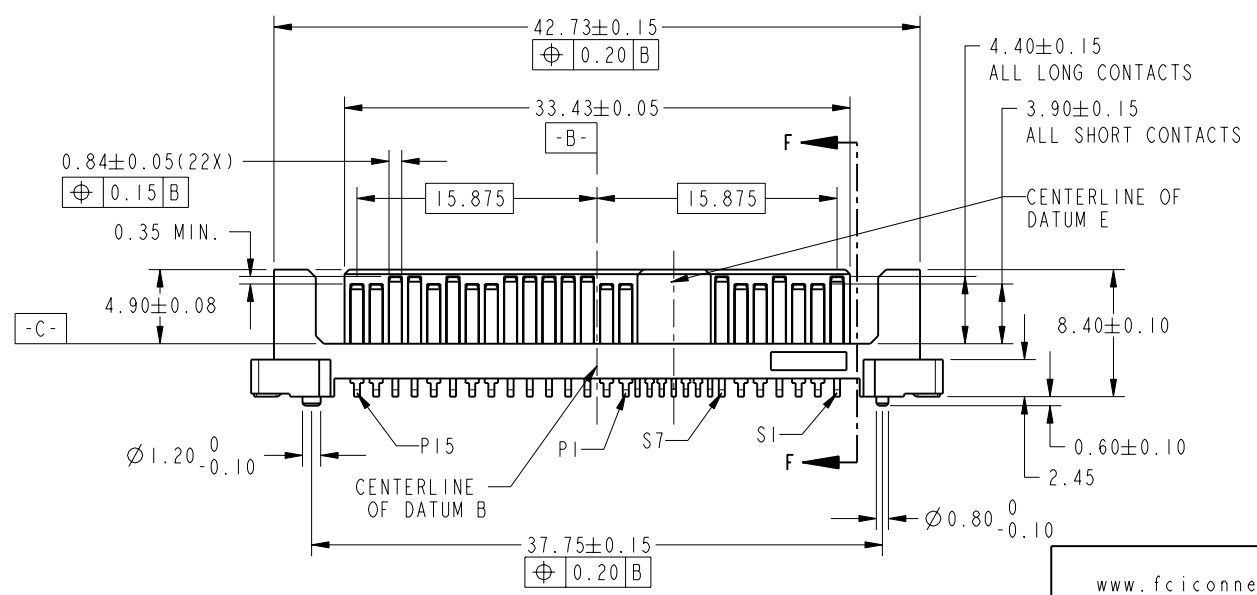
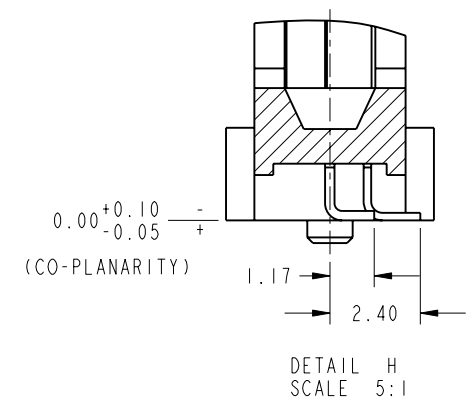
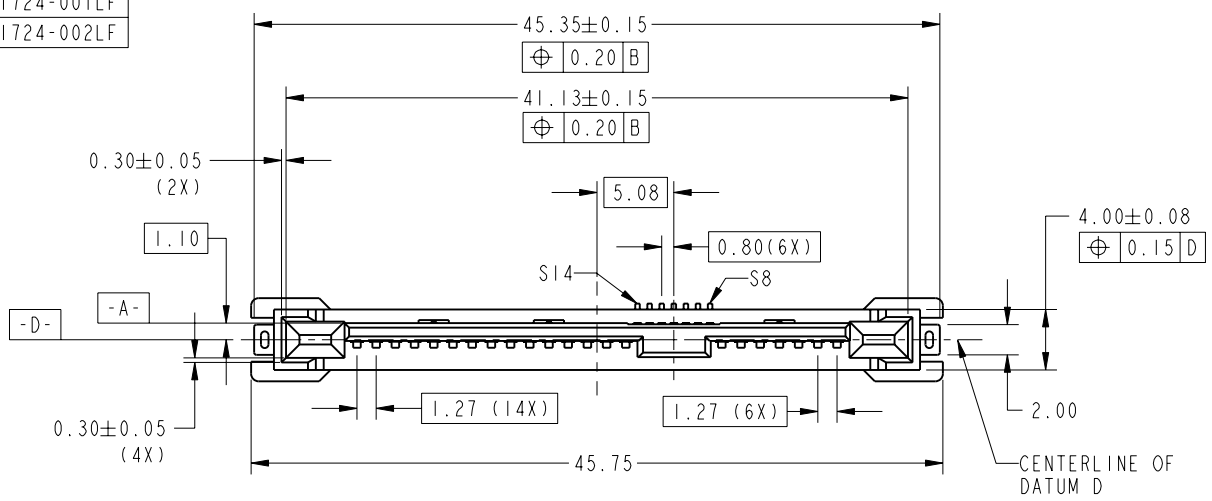

Copyright FCI.

rev	ecn no	dr	date
H	S07-0382	HKL	2007-11-02
B	S05-0368	HKL	2005-12-29
C	S06-0077	HKL	2006-03-13
D	S06-0182	HKL	2006-05-26
E	S06-0276	HKL	2006-08-18
F	S07-0107	HKL	2007-04-11
G	S07-0301	HKL	2007-09-05

www.fciconnect.com			surface ASME Y14.5	<input checked="" type="checkbox"/>	tolerance std ASME Y14.5	projection	MM
			TOLERANCES UNLESS OTHERWISE SPECIFIED				
Dr	SH TAN	2004-08-20	ANGULAR	0.X	±0.25	size	A4
Eng	HK LIM	2007-11-02	LINEAR	0.XX	±0.13	Scale	2:1
Chr	HK LIM	2007-11-02	0°	±2°	0.XXX	ECN	S07-0382
Appr	JOEY NG	2007-11-02	Product family		Spec ref		
FCI			SAS PLUG VERTICAL SMT ASSY		dwg no	10041724	Rev. H
			catalog no		CUSTOMER		sheet 1 of 3

REV E - 2006-03-28

PRODUCT NO.  
SEE TABLE

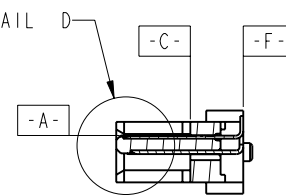
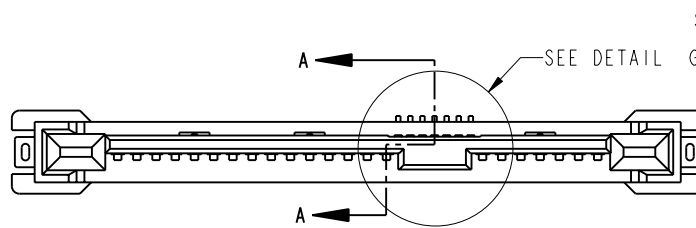
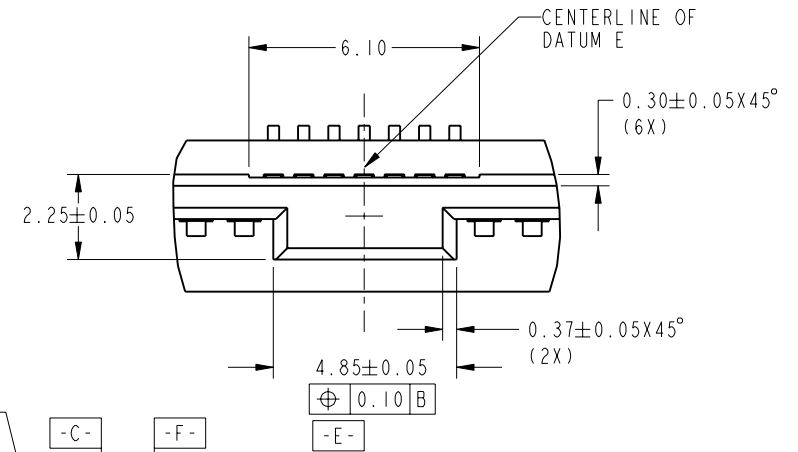
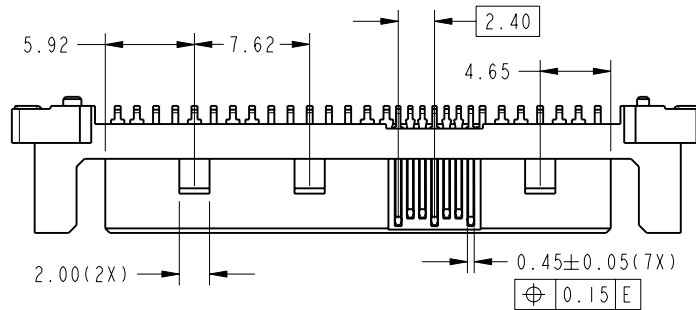

DETAIL G  
SCALE 5:1

SECTION A-A

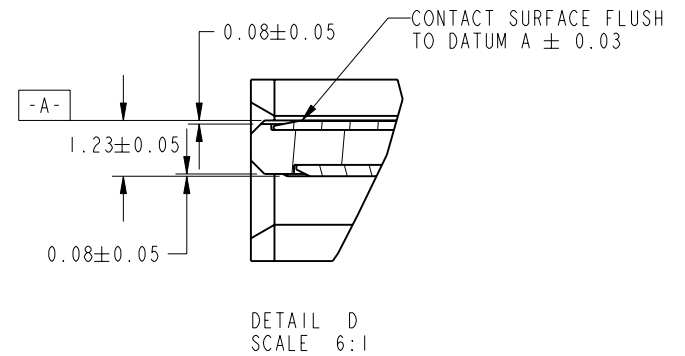
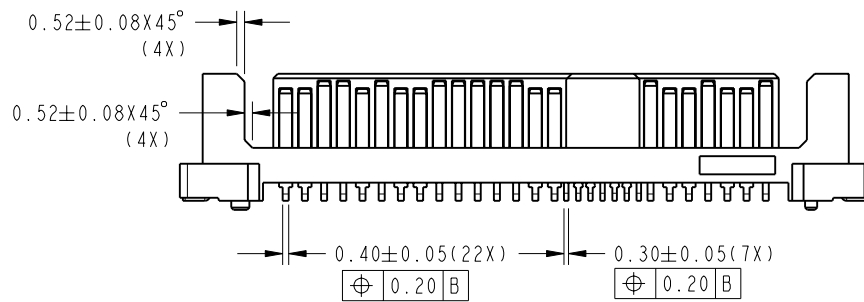

DETAIL D  
SCALE 6:1



Copyright FCI.



title SAS PLUG  
VERTICAL SMT ASSY  
catalog no

dwg no 10041724

Rev. H

CUSTOMER sheet 2 of 3

REV E - 2006-03-28

PDM: Rev:H

STATUS:Released

Printed: Dec 01, 2010

PRODUCT NO.	WITH PICK-UP CAP	PACKAGING	PLATING SPEC.
10041724-001LF/-002LF	NO	TRAY	-001LF REFER TO NOTE 2A
10041724-001CLF/-002CLF	YES		-002LF REFER TO NOTE 2B
10041724-001C-TRLF/-002C-TRLF			TAPE & REEL

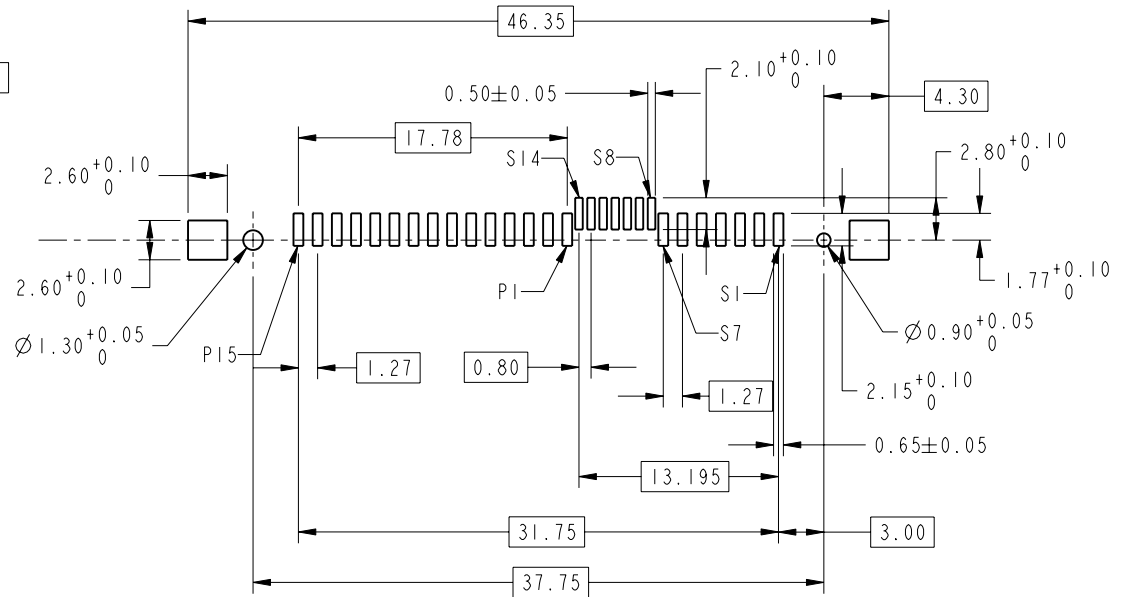
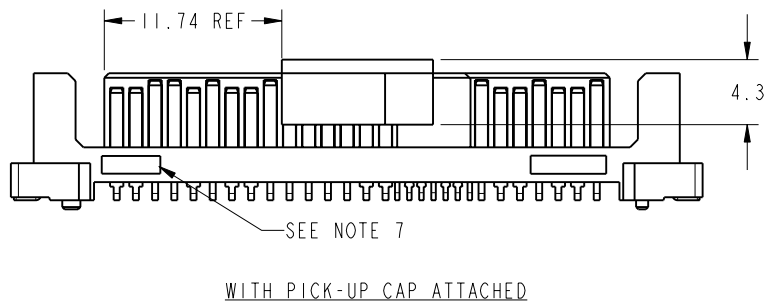
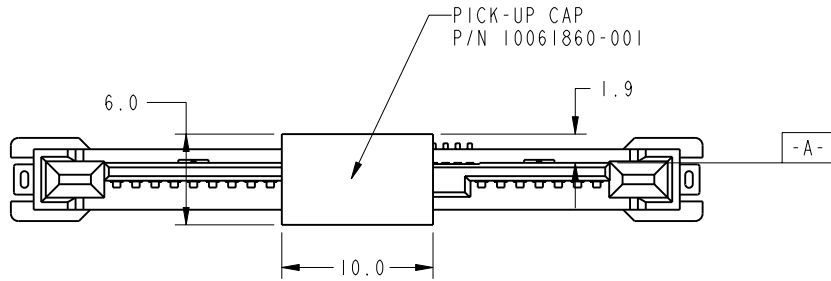

RECOMMENDED SOLDER PAD LAYOUT

NOTES:

- MATERIAL:  
HOUSING & PICK-UP CAP: HIGH TEMPERATURE PLASTIC, BLACK, UL94V-0  
CONTACT & HOLD DOWN: COPPER ALLOY
- FINISH:  
CONTACT: 1.27um MIN. NICKEL UNDERPLATE OVERALL,  
2.00um MIN. 100% MATTE TIN(LEAD FREE) ON SOLDER TAIL,  
A) 0.76um MIN. GOLD ON CONTACT AREA  
B) 0.76um MIN. GXT™ ON CONTACT AREA  
HOLD DOWN: 2.54um MIN. 100% MATTE TIN(LEAD FREE) OVER 1.27um MIN. NICKEL UNDERPLATE
- THIS PRODUCT MEETS EUROPEAN UNION DIRECTIVES AND OTHER COUNTRY REGULATIONS AS DESCRIBED IN GS-22-008
- THE HOUSING WILL WITHSTAND EXPOSURE TO 260°C PEAK TEMPERATURE FOR 10 SECONDS IN A CONVECTION, INFRA-RED OR VAPOR PHASE REFLOW OVEN
- PART WITH PICK-UP CAP, P/N XXXXXXXX-XXXCLF
- FOR TAPE & REEL PACKAGING, P/N XXXXXXXX-XXXC-TRLF
- THE PART SHALL HAVE "FCI" ID AND CAVITY NUMBER SHOWN IN THE APPROXIMATE LOCATION
- A SYMBOL  WILL BE NEXT TO ANY DIMENSION, VIEW OR NOTE WHICH HAS BEEN MODIFIED WITH THE CURRENT DRAWING REVISION

	TITLE	SAS PLUG VERTICAL SMT ASSY	dwg no	10041724	Rev.	H
	CATALOG NO		CUSTOMER		SHEET 3 OF 3	