



Chipsmall Limited consists of a professional team with an average of over 10 year of expertise in the distribution of electronic components. Based in Hongkong, we have already established firm and mutual-benefit business relationships with customers from,Europe,America and south Asia,supplying obsolete and hard-to-find components to meet their specific needs.

With the principle of “Quality Parts,Customers Priority,Honest Operation,and Considerate Service”,our business mainly focus on the distribution of electronic components. Line cards we deal with include Microchip,ALPS,ROHM,Xilinx,Pulse,ON,Everlight and Freescale. Main products comprise IC,Modules,Potentiometer,IC Socket,Relay,Connector.Our parts cover such applications as commercial,industrial, and automotives areas.

We are looking forward to setting up business relationship with you and hope to provide you with the best service and solution. Let us make a better world for our industry!



Contact us

Tel: +86-755-8981 8866 Fax: +86-755-8427 6832

Email & Skype: info@chipsmall.com Web: www.chipsmall.com

Address: A1208, Overseas Decoration Building, #122 Zhenhua RD., Futian, Shenzhen, China



CONNECTOR ASSY

<P/N composition> <P/N 構成>

10051922-24 1 LF

- Lead free
鉛フリー品
- Contact point plating variation (1: Au plating)
接点めっきバリエーション(1:金めっき)
- The number of contacts 極数
- Series name
シリーズ名

PARTS TABLE 部品表

No.	Part name 部品名	Material 材質	Finish めっき	Note 備考
①	Housing ハウジング	Enter glass fiber LCP resin ガラス繊維入り LCP樹脂	—	色:乳白色, UL94V-0 Color: Natural, UL94V-0
②	Actuator アクチュエーター	Enter glass fiber 9TPA resin ガラス繊維入り ポリアミド9T	—	色:黒, UL94V-0 Color: Black, UL94V-0
③	Contact コンタクト	Copper alloy 銅合金	Au plating (Nickel underplating) 金めっき (ニッケル下地めっき)	ニッケルダムあり With Ni dam on the contact
④	Fitting nail (Right side) 補強金具 (右側)	Copper alloy 銅合金	Tin alloy plating (Nickel underplating) スズ合金めっき (ニッケル下地めっき)	—
⑤	Fitting nail (Left side) 補強金具 (左側)	Copper alloy 銅合金	Tin alloy plating (Nickel underplating) スズ合金めっき (ニッケル下地めっき)	—

Au	14.5	15.72	17.5	1	1	30	1	1	10051922-301LF
	13.5	14.72	16.5	1	1	28	1	1	10051922-281LF
	12.5	13.72	15.5	1	1	26	1	1	10051922-261LF
	11.5	12.72	14.5	1	1	24	1	1	10051922-241LF
	10.5	11.72	13.5	1	1	22	1	1	10051922-221LF
	9.5	10.72	12.5	1	1	20	1	1	10051922-201LF
	9	10.22	12	1	1	19	1	1	10051922-191LF
	8.5	9.72	11.5	1	1	18	1	1	10051922-181LF
	7.5	8.72	10.5	1	1	16	1	1	10051922-161LF
	7	8.22	10	1	1	15	1	1	10051922-151LF
	6.5	7.72	9.5	1	1	14	1	1	10051922-141LF
	5.5	6.72	8.5	1	1	12	1	1	10051922-121LF
	5	6.22	8	1	1	11	1	1	10051922-111LF
	4.5	5.72	7.5	1	1	10	1	1	10051922-101LF
3.5	4.72	6.5	1	1	8	1	1	10051922-081LF	
CONTACT PLATING	DIM "C"	DIM "B"	DIM "A"	⑤ FITTING NAIL(L) QTY	④ FITTING NAIL(R) QTY	③ CONTACT QTY	② ACTUATOR QTY	① HOUSING QTY	PRODUCT NO.

mat'l. code ---				surface ISO 1302 ✓			tolerance ISO 406 ISO 1101			projection mm		product family 59GF FLEX 0.5		CODE JP	
tolerances unless otherwise specified				angles ±2°		linear 0.X ±0.3 0.XX ±0.3 0.XXX ±0.3			mm		title ASSEMBLY 0.5mm PITCH CONNECTOR FOR FPC VLL Series				
E REVISD J08-0283 N.S 2008-7-1 dr N.SASAME 2010-6-23				F REVISD J09-0178 N.S 2009-5-7 engr N.SASAME 2010-6-23				G ADDEDP/N J10-0142 N.S 2010-6-4 chr Y. Yamaguchi 2010-6-23				H REVISD J10-0171 N.S 2010-6-23 appd M. Kato Jun 23/10			
sheet index		revision sheet		dwg no		sheet 2 of 5		size		A3		type Product Customer Drawing			
				10051922				Rev.		H					



Copyright FCI

PRODUCT NO.	DIM "A"	DIM "B"	DIM "C"	DIM "D"	DIM "E"	CONTACT PLATING	Emboss QTY.	TOOLING AVAILABLE
10051922-0810ELF	16	7.5	21.5	8	--	Au	4500	YES
10051922-1010ELF								YES
10051922-1110ELF								YES
10051922-1210ELF								YES
10051922-1410ELF								YES
10051922-1510ELF	24	11.5	29.5	8	--	Au	4500	YES
10051922-1610ELF								YES
10051922-1810ELF								YES
10051922-1910ELF								YES
10051922-2010ELF								YES
10051922-2210ELF	32	14.2	37.5	8	28.4	Au	4500	YES
10051922-2410ELF								YES
10051922-2610ELF								YES
10051922-2810ELF								YES
10051922-3010ELF								YES

PARTS TABLE 部品表

No.	Part name 部品名	Material 材質	QTY.	Note 備考
①	The reel for packaging 梱包用リール	Polystyrene ポリスチレン	1	Color : White, Electrification prevention processing 色 : 白、帯電防止処理品
②	Emboss tape エンボステープ	PET	1	Electrification prevention processing 帯電防止処理品
③	Cover tape カバーテープ	Polyester ポリエステル	1	
④	Connector コネクタ	See sheet 1	4500	APPLIED FOR 8mm PITCH EMBOS TAPE

EMBOSS PACKAGE

NOTE

- This article carries out the emboss tape package of the 0.5mm pitch connector for FPC.
- The shape and dimension of this article are based on JIS C 0806.
(Taping of electronic parts (Surface mounted device))

注記

- 本品は 0.5mm ピッチ FPC 用コネクタをエンボステープ梱包したものである。
- 本品の形状及び寸法規定は JIS C 0806 (電子部品のテーピング (表面実装部品)) に準拠する。

<P/N composition> <P/N 構成>

10051922-16 1 0E LF

- Lead free
鉛フリー品
- Packaging form (0E : 8mm emboss pitch, Plastic reel・Embossing tape package)
梱包形態 (0E : 8mmエンボス穴ピッチ、プラスチックリール・エンボステープ梱包)
- Refer to connector drawing (Sheet 2).
コネクタ図面参照 (Sheet 2)

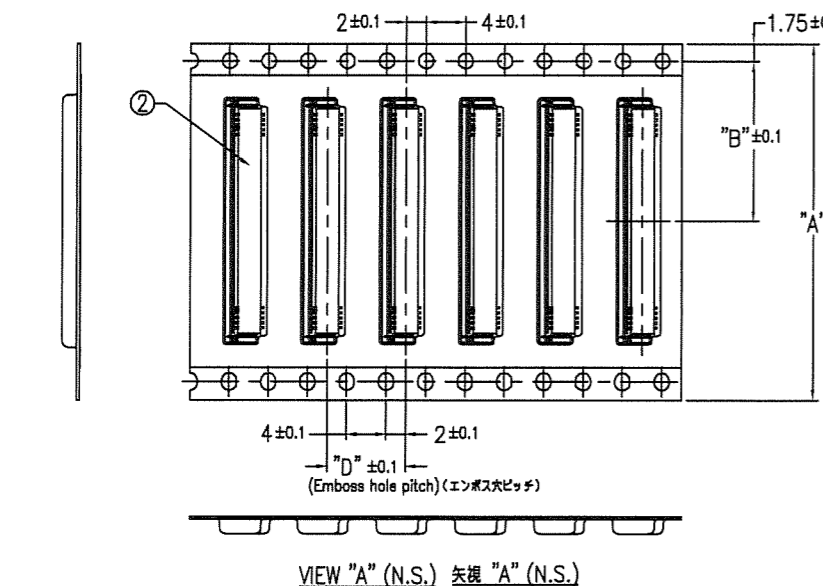
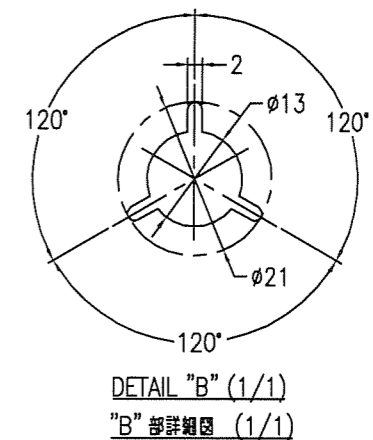
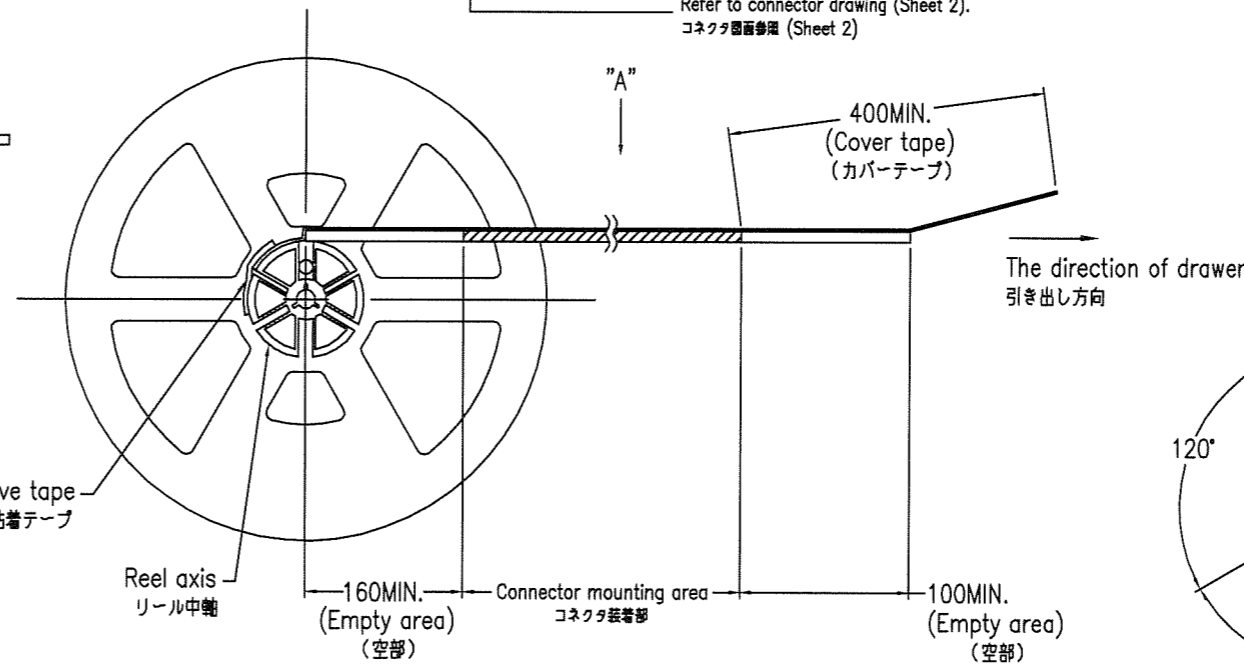
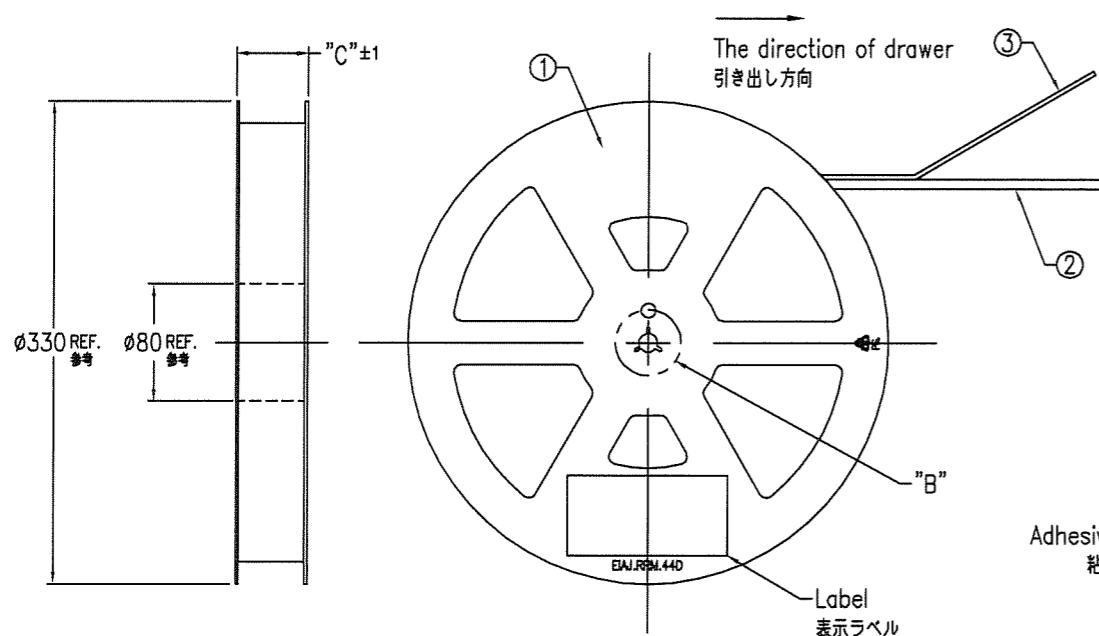

mat'l. code ---				surface ISO 1302 ✓		tolerance ISO 406 ISO 1101		projection mm		product family 59GF FLEX 0.5		CODE JP
ltr description ecn no dr date				tolerances unless otherwise specified		angles linear		scale 10:1		title ASSEMBLY 0.5mm PITCH CONNECTOR FOR FPC VLL Series		
A	RELEASED	J05-0356	N.S.	6/20/05	0.X ±0.3	±2°	0.XX ±0.3			dwg no sheet 4 of 5 size 10051922 A3		
E	REVISED	J08-0283	N.S.	2008-7-1	0.XXX ±0.3					type Product Customer Drawing		
F	REVISED	J09-0178	N.S.	2009-5-7							Rev. H	
G	ADDEDP/N	J10-0142	N.S.	2010-6-4								
H	REVISED	J10-0171	N.S.	2010-6-23								
sheet revision		index sheet										

PRODUCT NO.	DIM "A"	DIM "B"	DIM "C"	DIM "D"	DIM "E"	CONTACT PLATING	Emboss QTY.	TOOLING AVAILABLE
10051922-0810EHLF	16	7.5	21.5	8	---	Au	4500	YES
10051922-1010EHLF								YES
10051922-1110EHLF								YES
10051922-1210EHLF								YES
10051922-1410EHLF	24	11.5	29.5	8	---	Au	4500	YES
10051922-1510EHLF								YES
10051922-1610EHLF								YES
10051922-1810EHLF								YES
10051922-1910EHLF								YES
10051922-2010EHLF								YES
10051922-2210EHLF	32	14.2	37.5	8	28.4	Au	4500	YES
10051922-2410EHLF								YES
10051922-2610EHLF								YES
10051922-2810EHLF								YES
10051922-3010EHLF								YES
10051922-3010EHLF								YES

PARTS TABLE 部品表

No.	Part name 部品名	Material 材質	QTY.	Note 備考
①	The reel for packaging 梱包用リール	Polystyrene ポリスチレン	1	Color : White, Electrification prevention processing 色:白、帯電防止処理品
②	Emboss tape エンボステープ	PET	1	Electrification prevention processing 帯電防止処理品
③	Cover tape カバーテープ	Polyester ポリエステル	1	
④	Connector コネクタ	See sheet 1	4500	APPLIED FOR 8mm PITCH EMBOS TAPE

EMBOSS PACKAGE

HALOGEN FREE

NOTE

- This article carries out the emboss tape package of the 0.5mm pitch connector for FPC.
- The shape and dimension of this article are based on JIS C 0806.
(Taping of electronic parts (Surface mounted device))

注記

- 本品は 0.5mm ピッチ FPC 用コネクタをエンボステープ梱包したものである。
- 本品の形状及び寸法規定は JIS C 0806 (電子部品のテーピング (表面実装部品)) に準拠する。

<P/N composition> <P/N 構成>

10051922-16 1 0E H L F

Lead free
鉛フリー品
Halogen free
ハロゲンフリー品
Packaging form (0E : 8mm emboss pitch, Plastic reel・Embossing tape package)
梱包形態 (0E : 8mmエンボス穴ピッチ、プラスチックリール・エンボステープ梱包)
Refer to connector drawing (Sheet 2).
コネクタ図面参照 (Sheet 2)

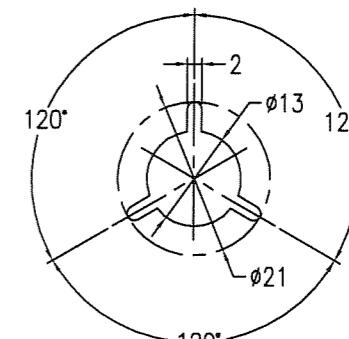
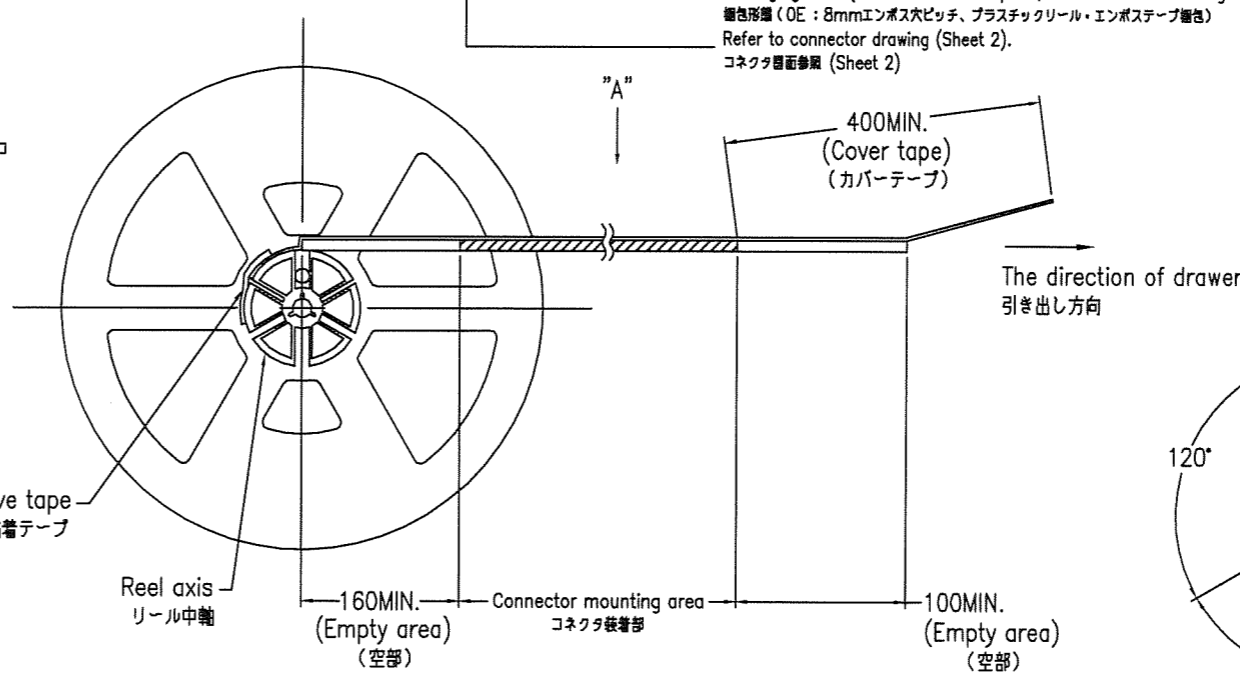
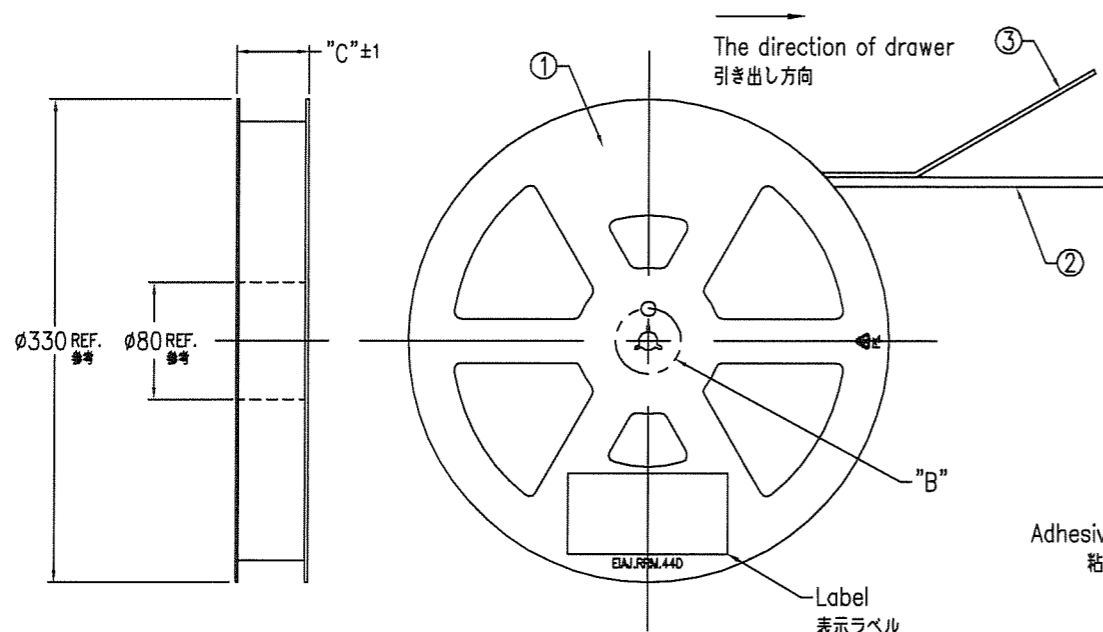

DETAIL "B" (1/1)
"B" 部詳細図 (1/1)

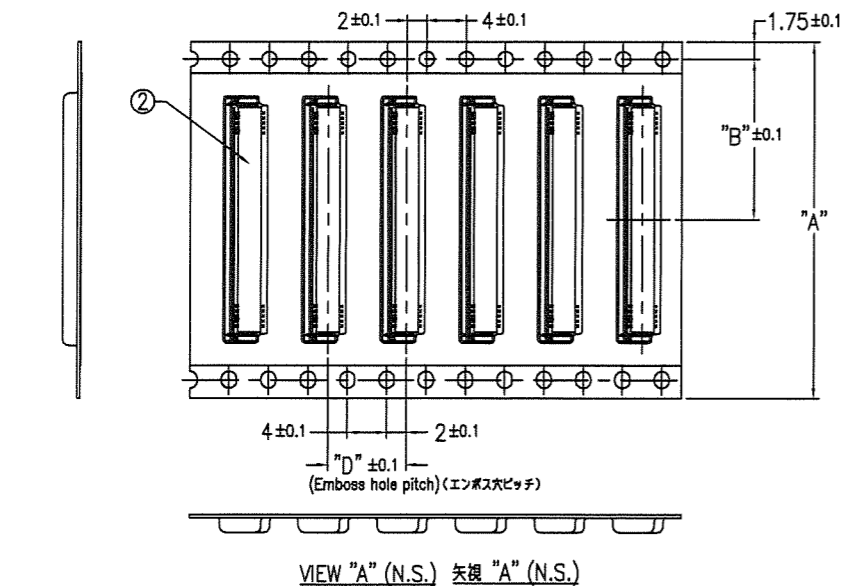

VIEW "A" (N.S.) 矢視 "A" (N.S.)

mat'l. code ---		surface ISO 1302 ✓		tolerance ISO 406 ISO 1101		projection mm		product family 59GF FLEX 0.5		CODE JP	
ltr description		ecn no		dr date		tolerances unless otherwise specified		title		ASSEMBLY	
						angles linear		0.5mm PITCH CONNECTOR FOR FPC		VLL Series	
						±2'		scale 10:1		sheet 5 of 5 size	
G ADDEDP/N		J10-0142		N.S. 2010-6-4		dr N.SASAME 2010-6-23		10051922		A3	
H REVISED		J10-0171		N.S. 2010-6-23		enr N.SASAME 2010-6-23		type Product Customer Drawing		Rev. H	
sheet index		revision sheet									



Copyright FCI