



Chipsmall Limited consists of a professional team with an average of over 10 year of expertise in the distribution of electronic components. Based in Hongkong, we have already established firm and mutual-benefit business relationships with customers from,Europe,America and south Asia,supplying obsolete and hard-to-find components to meet their specific needs.

With the principle of "Quality Parts,Customers Priority,Honest Operation,and Considerate Service",our business mainly focus on the distribution of electronic components. Line cards we deal with include Microchip,ALPS,ROHM,Xilinx,Pulse,ON,Everlight and Freescale. Main products comprise IC,Modules,Potentiometer,IC Socket,Relay,Connector.Our parts cover such applications as commercial,industrial, and automotives areas.

We are looking forward to setting up business relationship with you and hope to provide you with the best service and solution. Let us make a better world for our industry!



Contact us

Tel: +86-755-8981 8866 Fax: +86-755-8427 6832

Email & Skype: info@chipsmall.com Web: www.chipsmall.com

Address: A1208, Overseas Decoration Building, #122 Zhenhua RD., Futian, Shenzhen, China



PRODUCT NO.

10064555-**2**0*LF

PARTS TABLE 部品表

No.	Part name 部品名	Material 材質	QTY.	Note 備考
①	The reel for packaging 梱包用リール	Polystyrene ポリスチレン	1	Color : White, Electrification prevention processing 色 : 白、帯電防止処理品
②	Emboss tape エンボステープ	PP or PET	1	Electrification prevention processing 帯電防止処理品
③	Cover tape カバーテープ	Polyester ポリエステル	1	
④	Connector コネクタ	See sheet 2,3	3000	

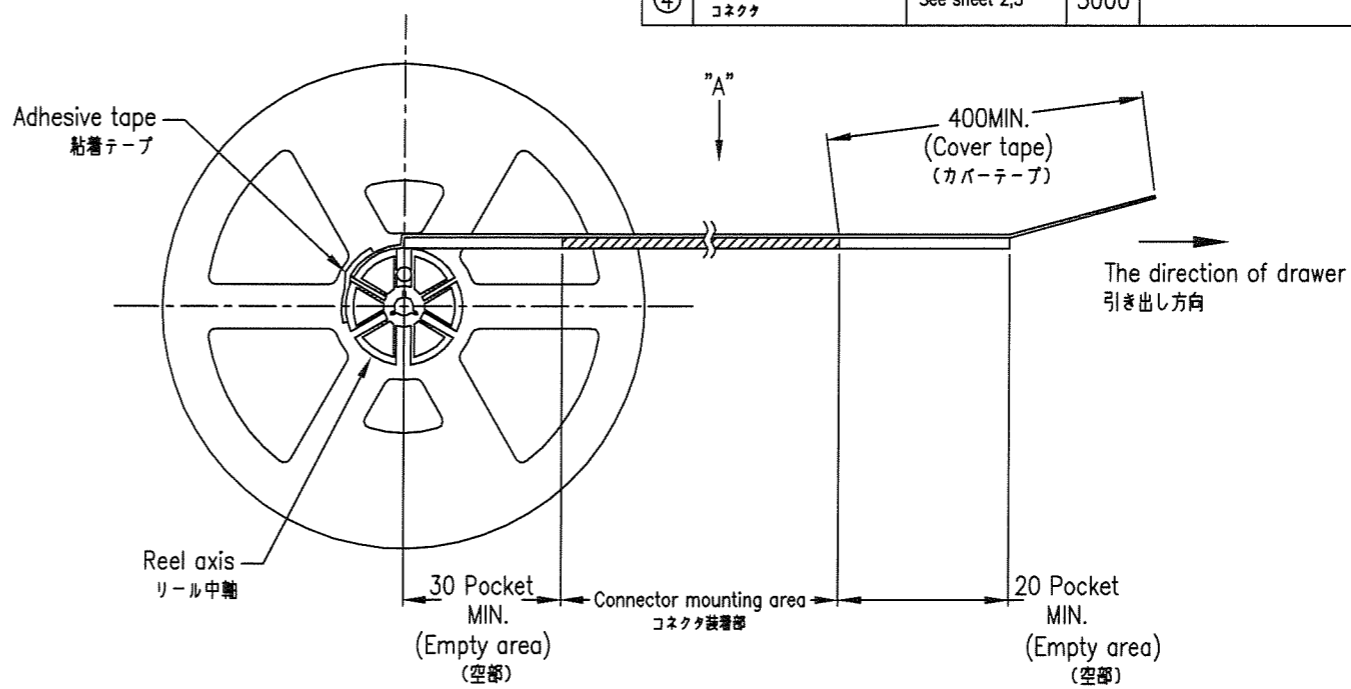
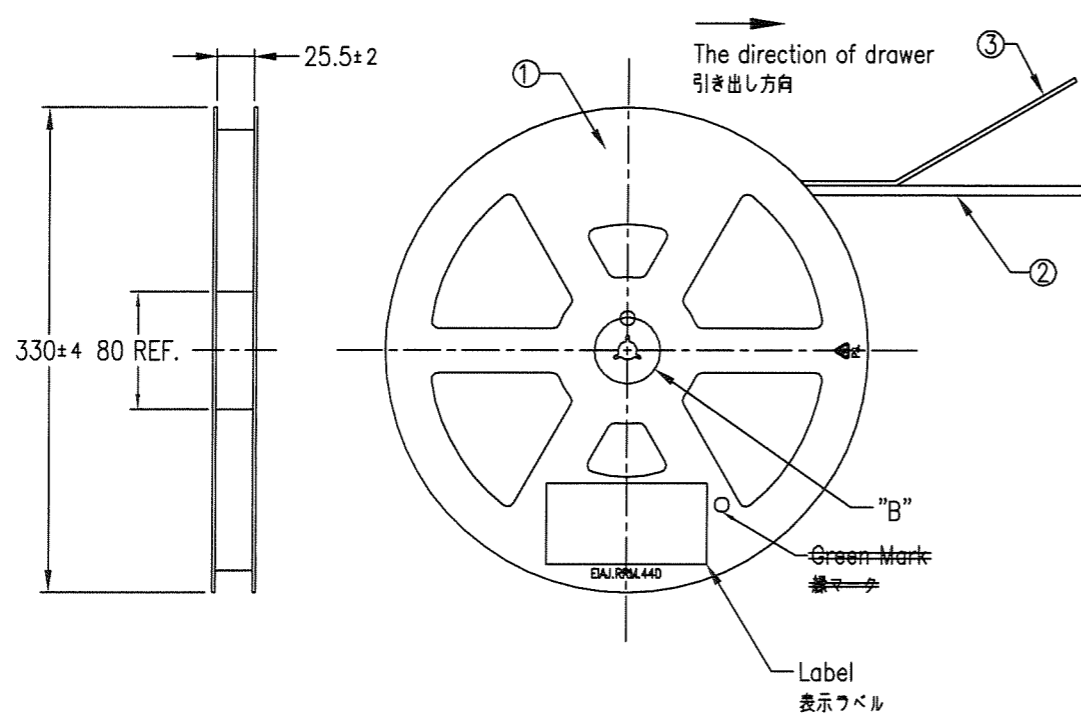

<P/N composition> <P/N 構成>

10064555-39 2 1 1 0 E LF

- Lead Free
- Mold material 1E : Non-Halogen free
- 2H : Halogen free
- Embossing tape package 0: 8mm PITCH
- TYPES OF PRODUCT 1: SMT / WITH CABLE LOCK
- 2: SMT / WITHOUT CABLE LOCK
- Contact Side 2: UPPER SIDE
- No of position
- Series name

NOTE

- This article carries out the emboss tape package of the P/N10064555 series connector.
- The shape and dimension of this article are based on JIS C 0806.
(Taping of electronic parts (Surface mounted device))

注記

- 本品は P/N10064555シリーズをエンボステープ梱包したものである。
- 本品の形状及び寸法規定は JIS C 0806 (電子部品のテーピング (表面実装部品)) に準拠する。

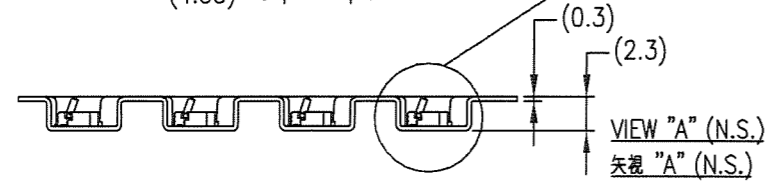
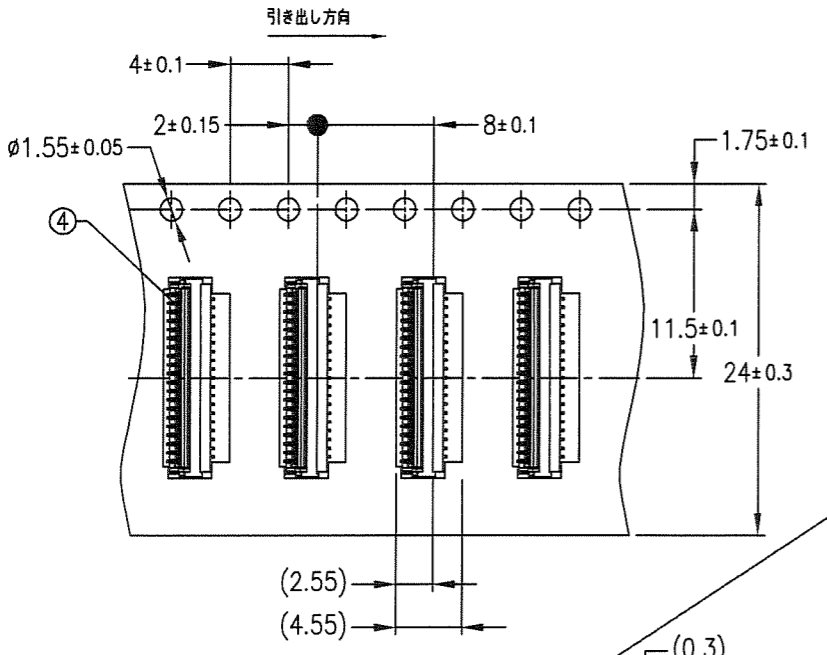
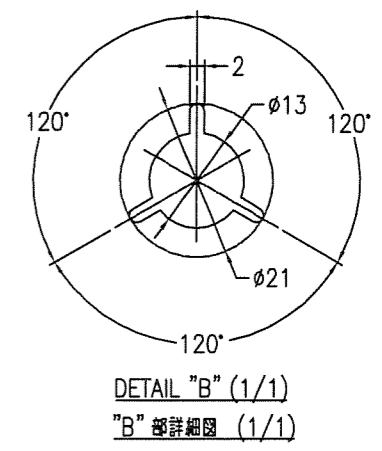

mat'l. code				surface		tolerance		projection		product family		CODE	
---				ISO 1302 ✓		ISO 406		MM		589F FLEX 0.3		JP	
tolerances unless otherwise specified				linear		0.X ±0.2		MM		title			
A RELEASED J06-0368 Y.K 09/06/'06				0'±2'		0.XX ±0.2		scale 1:5		ASSEMBLY			
B REVISED J07-0472 Y.K 2007-9-21						0.XXX ±0.2				0.3mm PITCH CONNECTOR FOR FPC			
C ADD NEW P/N J08-0064 Y.K 2008-2-12										YLL-U Series			
D ADD NEW P/N J08-0419 Y.K 2008-10-29				Y.KAMEDA		2011-03-16		FCJ		dwg no		sheet 1 of 3 size	
E ADD H/F P/N J11-0067 Y.K 2011-03-16				Y.KAMEDA		2011-03-16				10064555		A3	
				chr		2011-3-16				type		Product Customer Drawing	
sheet index				revision								Rev.	
1				E E E								E	

PRODUCT NO.

10064555-**21**LF

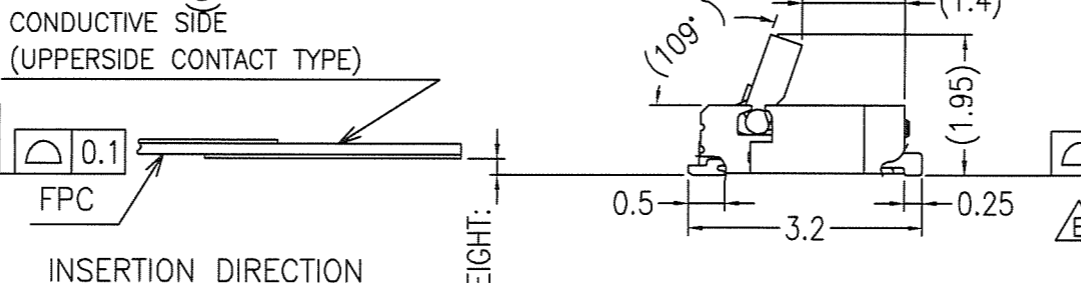
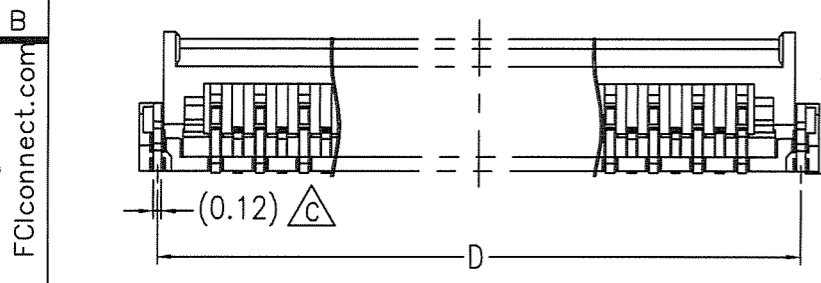
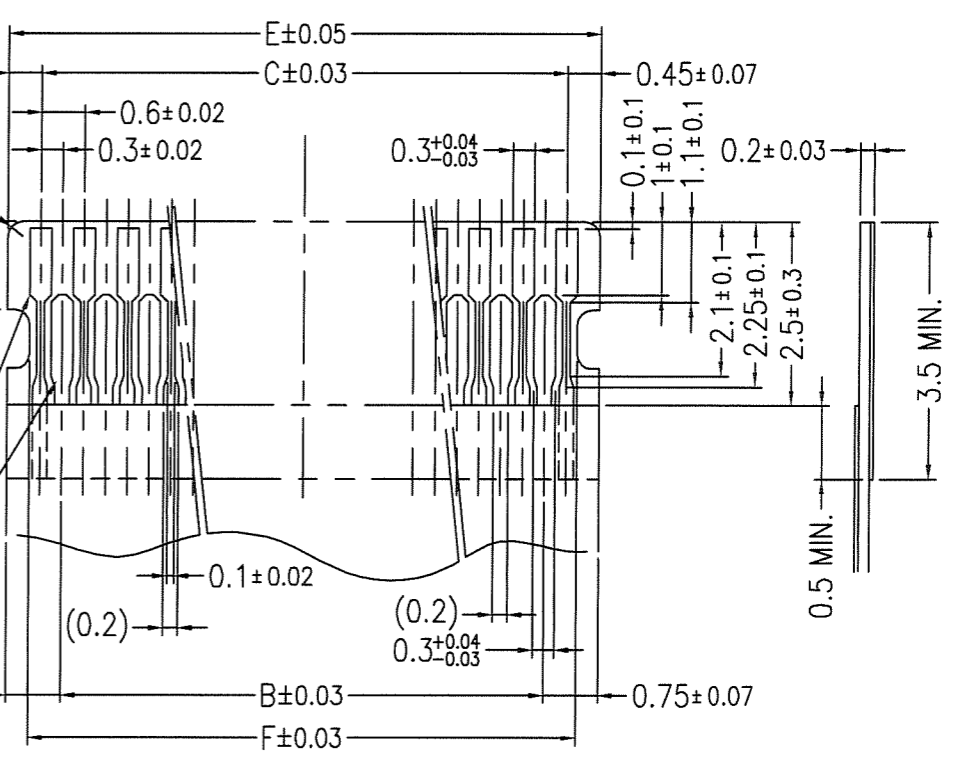
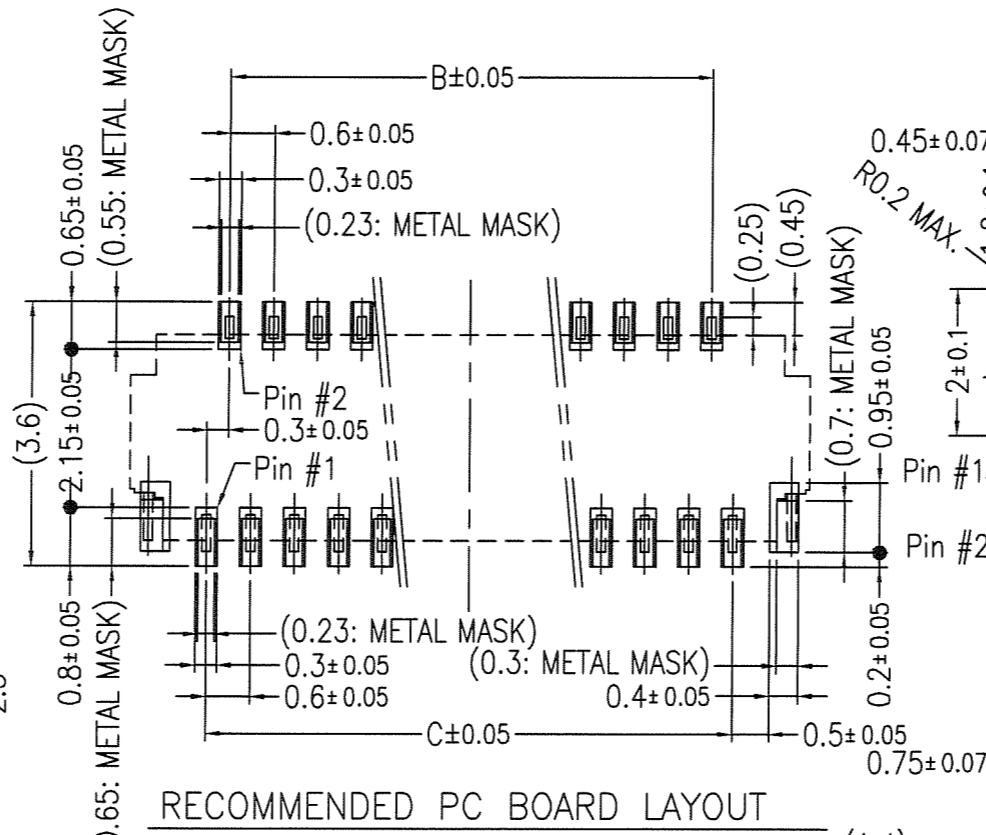
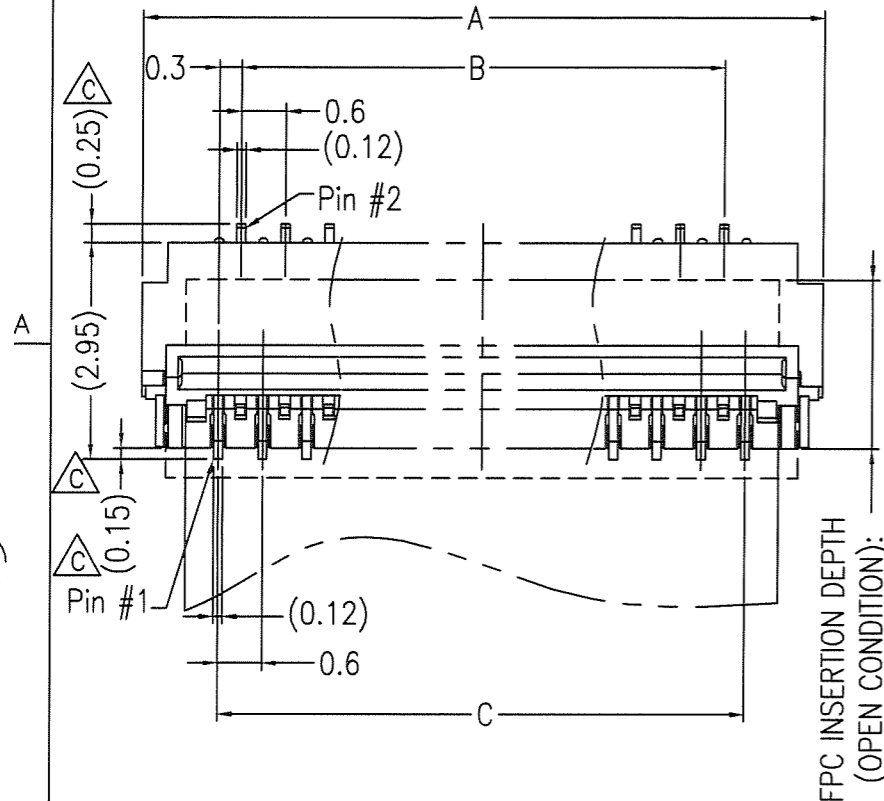

NOTE

- MATERIAL
 - HOUSING: THERMOPLASTIC RESIN, UL94V-0, BLACK
 - ACTUATOR: THERMOPLASTIC RESIN, UL94V-0, BEIGE
 - CONTACT: COPPER ALLOY
 - FIXING TAB: COPPER ALLOY
- FINISH
 - CONTACT: ALL OVER Ni, (CONTACT AREA) Au FLASH, (SOLDER TAIL AREA) Au FLASH.
 - FIXING TAB: ALL OVER Ni, Sn PLATING 1.5~3.5μm
- CO-PLANARITY: 0.1 MAX.
- THICKNESS OF A METAL MASK: 0.1mm
- FPC
 - ADHESIVE METHOD OF SUPPORTING TAPE SHALL BE HEAT CRIMPING METHOD AND THERMOSETTING ADHESIVE MATERIAL SHALL BE USED.
- PRODUCT
 - * MARK ITEM IS REFERENCE.
 - RECOMMENDED PCB LAYOUT and FPC ARE THE SAME AS 10061122-**1110ELF(YLL-DOWN CONTACT TYPE).
- OTHER

THIS PRODUCT MEETS EUROPEAN UNION DIRECTIVES AND OTHER COUNTRY REGULATIONS AS DESCRIBED IN GS-22-008

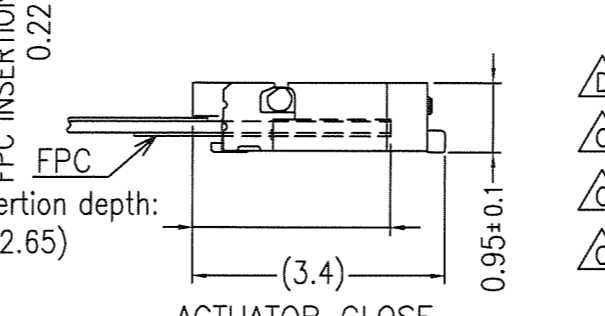

10064555-39211LF	13.5	10.8	11.4	13.0	12.3	11.7
10064555-39212HLF						
10064555-35211LF	12.3	9.6	10.2	11.8	11.1	10.5
10064555-33211LF	11.7	9	9.6	11.2	10.5	9.9
10064555-31211LF	11.1	8.4	9	10.6	9.9	9.3
10064555-25211LF	9.3	6.6	7.2	8.8	8.1	7.5
10064555-21211LF	8.1	5.4	6.0	7.6	6.9	6.3
10064555-15211LF	6.3	3.6	4.2	5.8	5.1	4.5
P/N	A	B	C	D	E	F

mat'l. code	surface	tolerance	projection	product family	CODE
---	ISO 1302 ✓	ISO 406 ISO 1101	MM	589F FLEX 0.3	JP
ltr	description	ecn no	dr	date	tolerances unless otherwise specified
A	RELEASED	J06-0368	Y.K	09/06/'06	angles linear 0.X ±0.2
B	REVISED	J07-0472	Y.K	2007-9-21	0.XX ±0.2
C	ADD NEW P/N	J08-0064	Y.K	2008-2-12	0'±2'
D	ADD NEW P/N	J08-0419	Y.K	2008-10-29	dr Y.KAMEDA 2011-03-18
E	ADD NEW P/N	J11-0067	Y.K	2011-03-16	engr Y.KAMEDA 2011-03-18
					chr Y.KAMEDA 2011-3-16
					appd M. Kawano Mar 16/11
sheet index	revision sheet				
					Rev. E

PRODUCT NO.

10064555-**22*LF

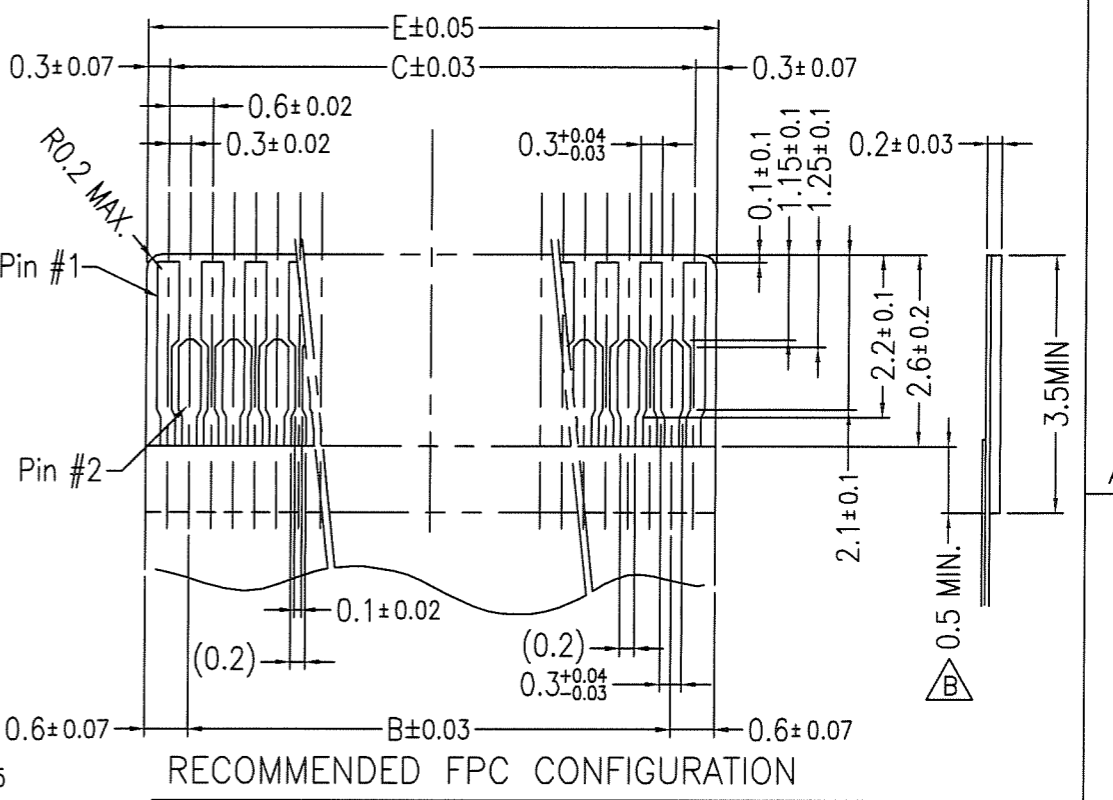
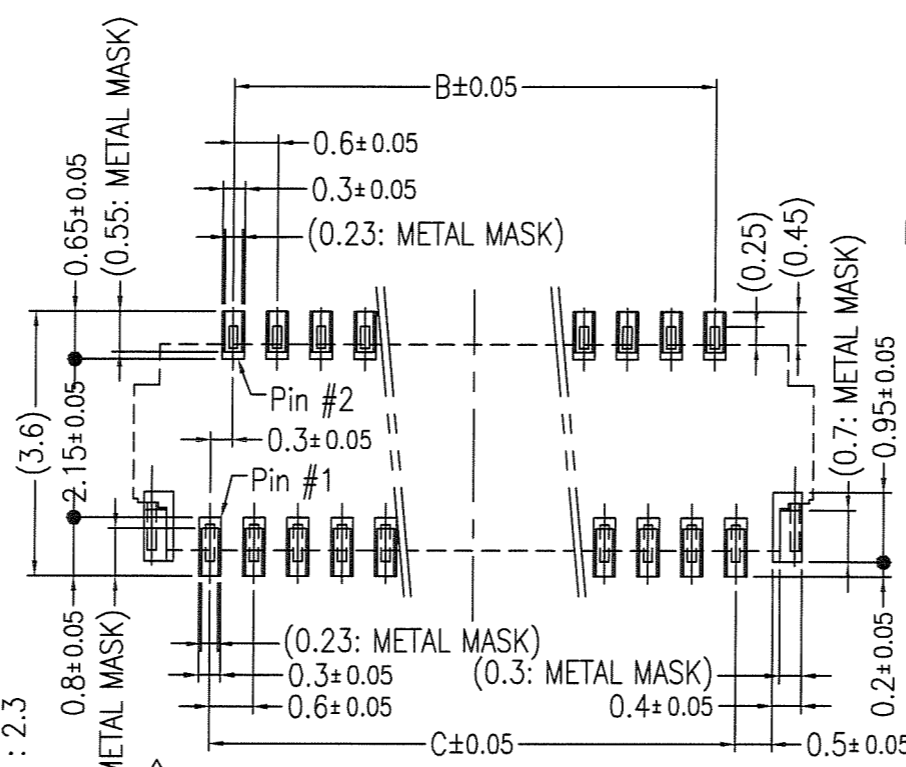
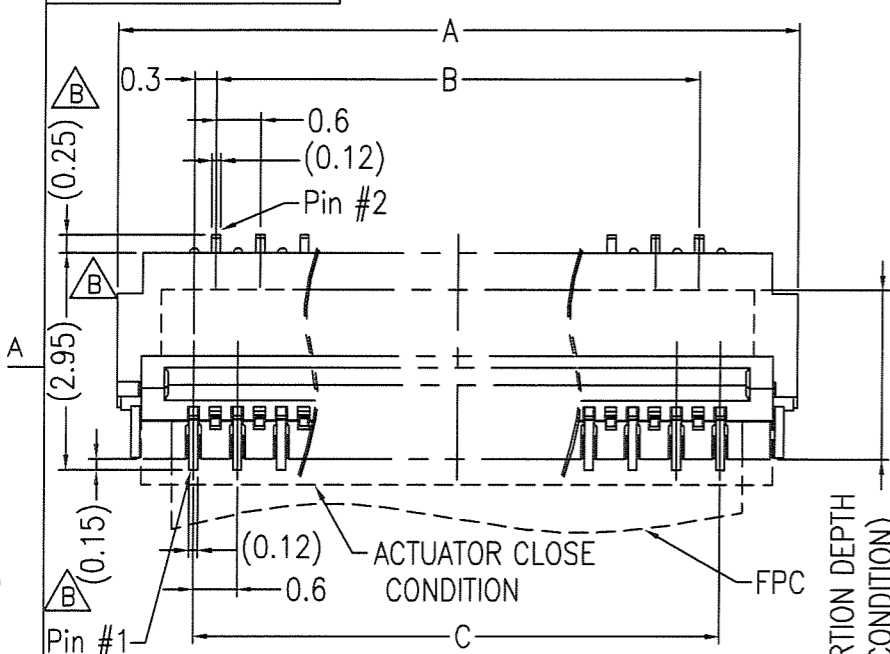

RECOMMENDED PC BOARD LAYOUT

RECOMMENDED FPC CONFIGURATION

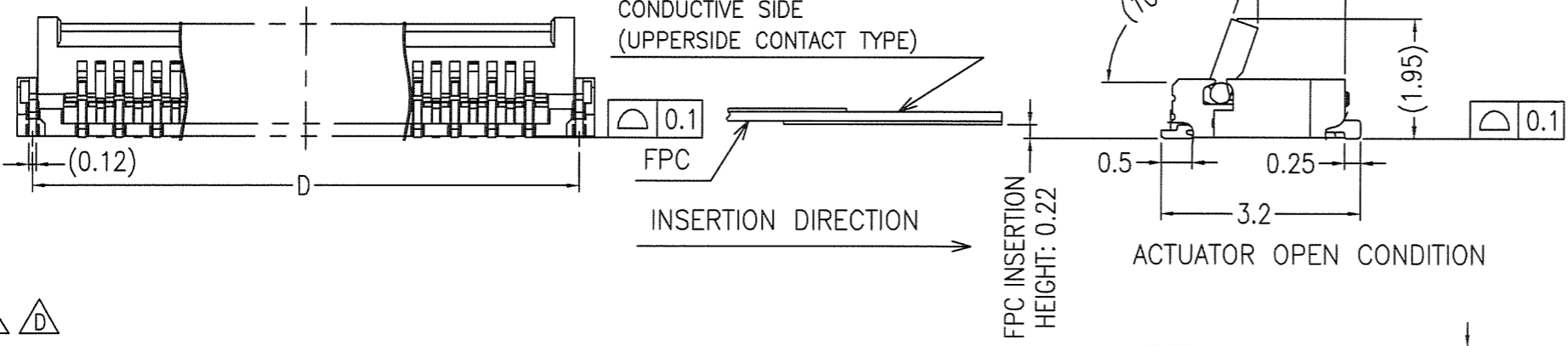

ACTUATOR OPEN CONDITION

ACTUATOR CLOSE CONDITION

10064555-41221LF	14.1	11.4	12.0	13.6	12.6
10064555-39221LF	13.5	10.8	11.4	13.0	12.0
10064555-37221LF	12.9	10.2	10.8	12.4	11.4
10064555-33221LF	11.7	9	9.6	11.2	10.2
10064555-31221LF	11.1	8.4	9	10.6	9.6
10064555-27221LF	9.9	7.2	7.8	9.4	8.4
10064555-25221LF	9.3	6.6	7.2	8.8	7.8
10064555-23221LF	8.7	6	6.6	8.2	7.2
10064555-21221LF	8.1	5.4	6.0	7.6	6.6
10064555-15222HLF	8.1	5.4	6.0	7.6	6.6
P/N	A	B	C	D	E

NOTE

1. MATERIAL
 1) HOUSING: THERMOPLASTIC RESIN, UL94V-0, BLACK
 2) ACTUATOR: THERMOPLASTIC RESIN, UL94V-0, BEIGE
 3) CONTACT: COPPER ALLOY
 4) FIXING TAB: COPPER ALLOY

2. FINISH
 1) CONTACT: ALL OVER Ni, (CONTACT AREA) Au FLASH. (SOLDER TAIL AREA) Au FLASH.
 2) FIXING TAB: ALL OVER Ni, Sn PLATING 1.5~3.5μm

3. CO-PLANARITY: 0.1 MAX.

4. THICKNESS OF A METAL MASK: 0.1mm

5. FPC
 1) ADHESIVE METHOD OF SUPPORTING TAPE SHALL BE HEAT CRIMPING METHOD AND THERMOSETTING ADHESIVE MATERIAL SHALL BE USED.

6. PRODUCT
 1) RECOMMENDED PCB LAYOUT and FPC ARE THE SAME AS 10061122-**1110ELF(YLL-DOWN CONTACT TYPE).

7. OTHER
 THIS PRODUCT MEETS EUROPEAN UNION DIRECTIVES AND OTHER COUNTRY REGULATIONS AS DESCRIBED IN GS-22-008

mat'l. code		surface		tolerance		projection		product family		CODE	
---		ISO 1302		ISO 406		MM		589F FLEX 0.3		JP	
---		ISO 1101		tolerances unless otherwise specified		MM		title		ASSEMBLY	
---		0°±2'		linear		scale 10:1		0.3mm PITCH CONNECTOR FOR FPC		YLL-U Series	
---		Y.KAMEDA		2011-03-18		FCJ		dwg no		sheet 3 of 3 size	
---		Y.KAMEDA		2011-03-18		10064555		10064555		A3	
---		chr		2011-03-18		type		Product Customer Drawing		Rev.	
---		app		2011-03-18		Rev.		E		E	

FCI connect.com

Copyright FCI.