



Chipsmall Limited consists of a professional team with an average of over 10 year of expertise in the distribution of electronic components. Based in Hongkong, we have already established firm and mutual-benefit business relationships with customers from,Europe,America and south Asia,supplying obsolete and hard-to-find components to meet their specific needs.

With the principle of “Quality Parts,Customers Priority,Honest Operation,and Considerate Service”,our business mainly focus on the distribution of electronic components. Line cards we deal with include Microchip,ALPS,ROHM,Xilinx,Pulse,ON,Everlight and Freescale. Main products comprise IC,Modules,Potentiometer,IC Socket,Relay,Connector.Our parts cover such applications as commercial,industrial, and automotives areas.

We are looking forward to setting up business relationship with you and hope to provide you with the best service and solution. Let us make a better world for our industry!



Contact us

Tel: +86-755-8981 8866 Fax: +86-755-8427 6832

Email & Skype: info@chipsmall.com Web: www.chipsmall.com

Address: A1208, Overseas Decoration Building, #122 Zhenhua RD., Futian, Shenzhen, China



IPD Ultima

Premium USB desktop controllers

Distinctive features and specifications



- ❑ 3 axis joystick for PTZ control
- ❑ LED pushbutton switches
- ❑ USB 2.0 HID compliant “game controller”
- ❑ Soft touch Business Blue coating

- Joystick performance:
 - Hall effect three axis joystick
 - X/Y/Z for positioning control
- Joystick travel:
 - 36° for X and Y axis
 - 60° for Z axis
- Centering: Single spring, omni-directional
- Joystick shaft: Stainless steel
- Joystick boot: Neoprene
- Joystick handle: Glass filled nylon
- Pushbutton performance:
 - 10 vibrant, high efficiency back lit LED pushbuttons rated for 10,000,000 life cycles
 - Two tactile pushbuttons on joystick rated for 3,000,000 life cycles
- Desktop housing:
 - High impact ABS
 - Soft touch Business Blue coating
- Power:
 - Via USB interface (5V DC)

- Operating conditions: -25° to +85° C (-13 to +185° F)
- Approvals:
 - EN 55024:1998, EN 55022, CE
 - FCC Part 15 Subpart B Class B
 - RoHs compliant
- Weight: 455 g (1.00lb)
- Interface: USB port
- Connectors:
 - USB Type A Male
 - Cable Length: 2m; 6ft. 6.8in.
- Systems support integration: Windows 7, 8, 10 & OSX
- Supported protocols:
 - USB HID 1.1 game controller
 - Direct X (Gaming Control)
 - Joystick: Three HID axis
 - Pushbuttons: 12 HID buttons
 - Uses standard DirectX HID drivers
 - Connects directly to workstation PC
- Environmental: For indoor use only

NOTE: All values are nominal.

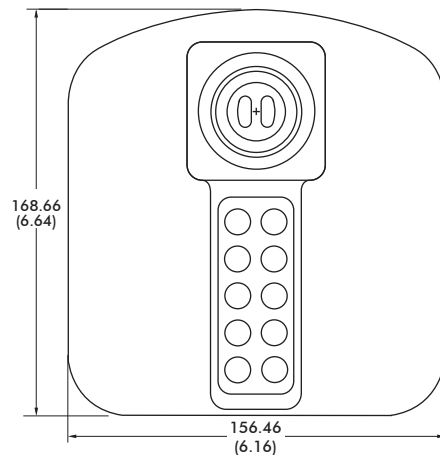
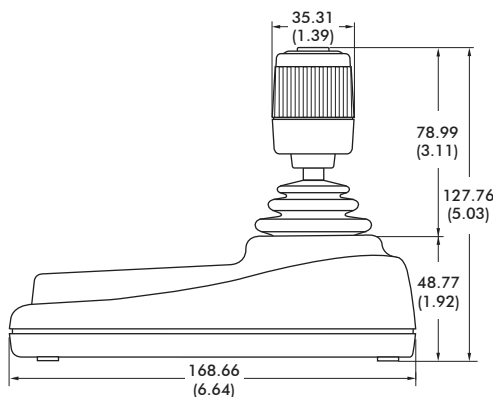

NOTES:

Dimensions are in mm/(inch).

To order the IP Desktop please refer to Part Number 100-650.