



Chipsmall Limited consists of a professional team with an average of over 10 year of expertise in the distribution of electronic components. Based in Hongkong, we have already established firm and mutual-benefit business relationships with customers from,Europe,America and south Asia,supplying obsolete and hard-to-find components to meet their specific needs.

With the principle of “Quality Parts,Customers Priority,Honest Operation,and Considerate Service”,our business mainly focus on the distribution of electronic components. Line cards we deal with include Microchip,ALPS,ROHM,Xilinx,Pulse,ON,Everlight and Freescale. Main products comprise IC,Modules,Potentiometer,IC Socket,Relay,Connector.Our parts cover such applications as commercial,industrial, and automotives areas.

We are looking forward to setting up business relationship with you and hope to provide you with the best service and solution. Let us make a better world for our industry!



Contact us

Tel: +86-755-8981 8866 Fax: +86-755-8427 6832

Email & Skype: info@chipsmall.com Web: www.chipsmall.com

Address: A1208, Overseas Decoration Building, #122 Zhenhua RD., Futian, Shenzhen, China



PRODUCT NO	MOTOROLA P/N	DIM A	DIM B	DIM C	DIM D	DIM E	DIM F	REMARK
10067099-100LF	3971730C03	3.05MM	1.85MM	3.40MM	1.00MM	1.20MM	3.05MM	NO PROTECTION
10067099-200LF	3971730C02	2.65MM	1.45MM	3.50MM	0.90MM	1.00MM	2.95MM	NO PROTECTION
10067099-400LF	3971730C03	3.05MM	1.85MM	3.40MM	1.00MM	1.20MM	3.05MM	WITH PROTECTION
10067099-500LF	3971730C02	2.65MM	1.45MM	3.50MM	0.90MM	1.00MM	2.95MM	WITH PROTECTION

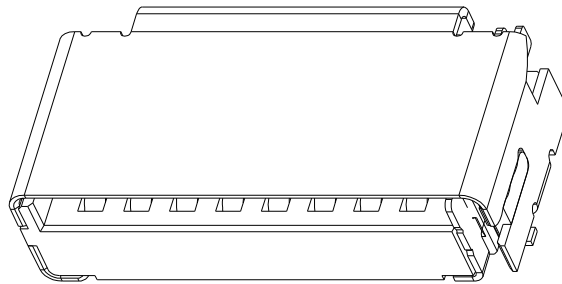

10067099-100LF/200LF

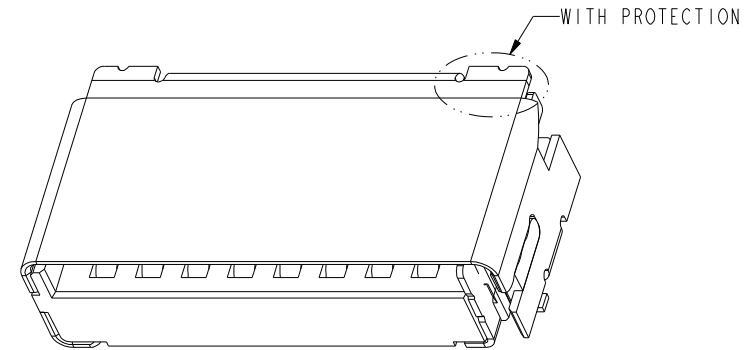

10067099-400LF/500LF



NOTES:

- MATERIAL:
 HOUSING: 30% G/F LCP, UL 94V-0, COLOR: BLACK.
 CONTACT & DETECT PIN: COPPER ALLOY, THICKNESS=0.15MM.
 CONTACT PLATING: 50u" MIN. OF Ni UNDERPLATE, GOLD FLASH OVER ALL, CONTACT AREA PLATING 30u" GOLD.
 DETECT PIN PLATING: 50u" MIN. OF Ni UNDERPLATE, GOLD FLASH ON CONTACT AREA, TIN PLATED ON SOLDER AREA.
 BRACKET: STAINLESS STEEL, THICKNESS=0.20MM, GOLD FLASH ON SOLDER AREA.
- PRODUCT PERFORMANCE SPEC. PER GS-12-451.
- PACKAGE SPEC. PER GS-14-1162.
- "■" REPRESENT CRITICAL DIMS AND NEED TO MEET $C_{pk} > 1.5$
- THIS PRODUCT IS RoHS COMPLIANT, AND MEETS EUROPEAN UNION DIRECTIVES AND OTHER COUNTRY REGULATIONS AS PER GS-22-008.
- A SYMBOL WILL BE NEXT TO ANY DIMENSION, VIEW OR NOTE WHICH HAS BEEN MODIFIED WITH CURRENT DRAWING VERSION.

rev	ecn no	dr	date
A	DG07-0087	DT	2007.03.15
B	DG07-0098	DT	2007.04.04
C	DG08-0005	SH	2008.01.04
D	DG08-0339	SH	2008.12.04
E	DG10-0457	SM	2010.12.21
F	DG10-0462	SM	2010.12.28
G	DG11-0034	SM	2011.02.11

www.fciconnect.com		surface <input checked="" type="checkbox"/>	tolerance std	projection	MM
		TOLERANCES UNLESS OTHERWISE SPECIFIED			
Dr	DAVID TENG	2007-02-12	ANGULAR	size A4	Scale 1.000
Eng	DAVID TENG	2007-02-12	LINEAR	ECN	DG11-0034
Chr	PAUL WANG	2007-02-12	0° ±2°	0.X ±0.30	
Appr	Joseph Hsia	2007-02-12	0.XX ±0.15	0.XXX ±0.08	
Product family Mobile I/O			Spec ref		
		title TFLASH CONNECTOR ASSEMBLY TFLASH CONNECTOR WITH CARD DETECTING		dwg no 10067099	Rev. G
catalog no 10067099			CUSTOMER		sheet 1 of 3

PRODUCT NO	MOTOROLA P/N	DIM A	DIM B	DIM C	DIM D	DIM E	DIM F	REMARK
10067099-100LF	3971730C03	3.05MM	1.85MM	3.40MM	1.00MM	1.20MM	3.05MM	NO PROTECTION
10067099-200LF	3971730C02	2.65MM	1.45MM	3.50MM	0.90MM	1.00MM	2.95MM	NO PROTECTION

A

B

C

D

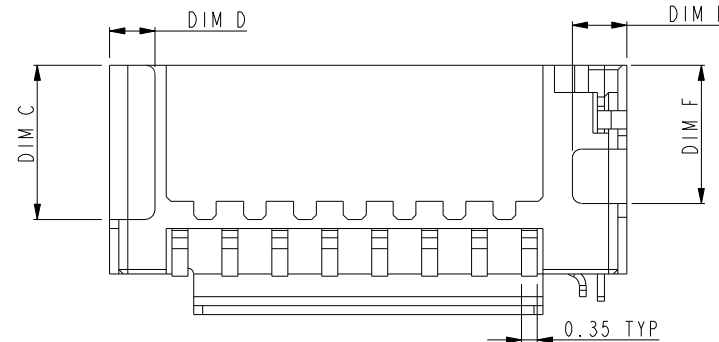
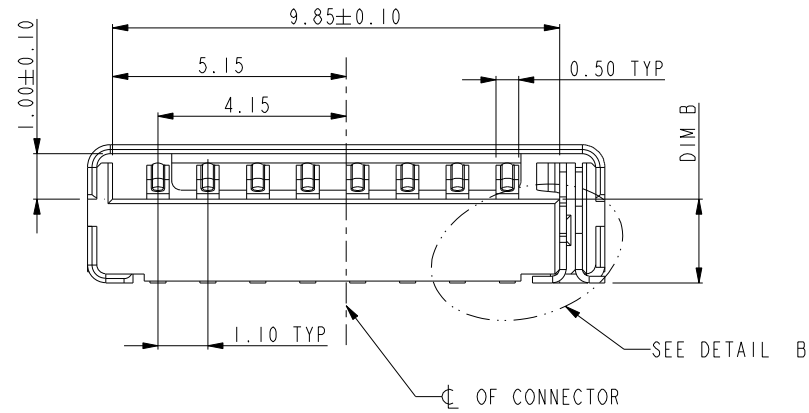
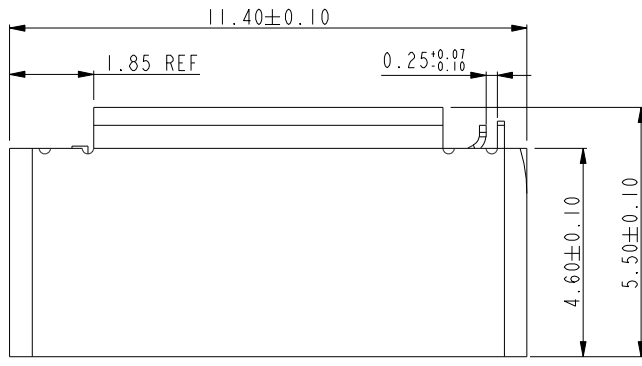

SCALE 6.000

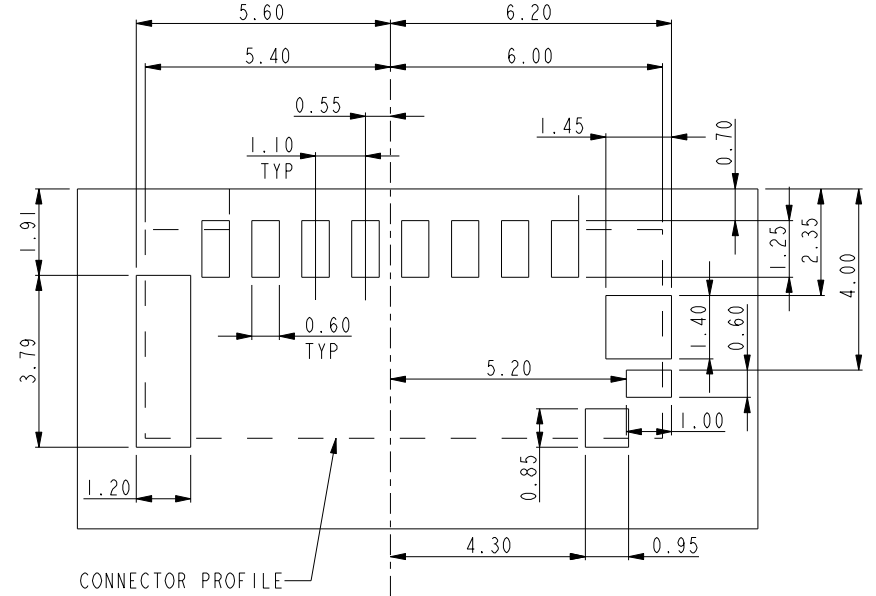

CONNECTOR PROFILE

RECOMMENDED PCB LAYOUT

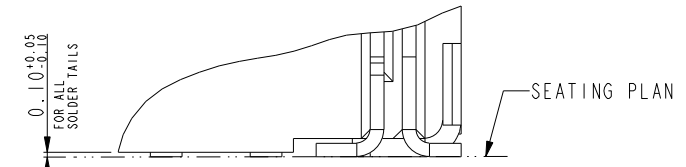
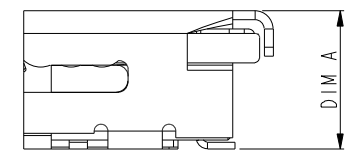

ALL SOLDER TAILS CO-PLANARITY FROM SEATING PLANE: 0.08MM MAX.

DETAIL B
SCALE 12.000

TOLERANCES UNLESS OTHERWISE SPECIFIED		
LINEAR	0.X	±0.30
	0.XX	±0.15
ANGULAR	0.XXX	±0.08
	0°	±2°

	title TFLASH CONNECTOR ASSEMBLY TFLASH CONNECTOR WITH CARD DETECTING	dwg no 10067099	Rev. G
	catalog no 10067099	CUSTOMER	sheet 2 of 3

PRODUCT NO	MOTOROLA P/N	DIM A	DIM B	DIM C	DIM D	DIM E	DIM F	REMARK
10067099-400LF	3971730C03	3.05MM	1.85MM	3.40MM	1.00MM	1.20MM	3.05MM	WITH PROTECTION
10067099-500LF	3971730C02	2.65MM	1.45MM	3.50MM	0.90MM	1.00MM	2.95MM	WITH PROTECTION

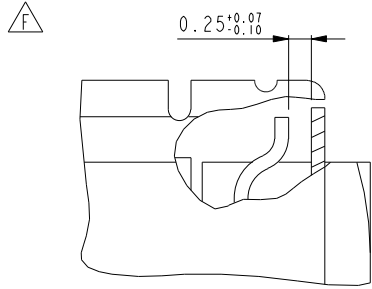

DETAIL C
SCALE 12.000

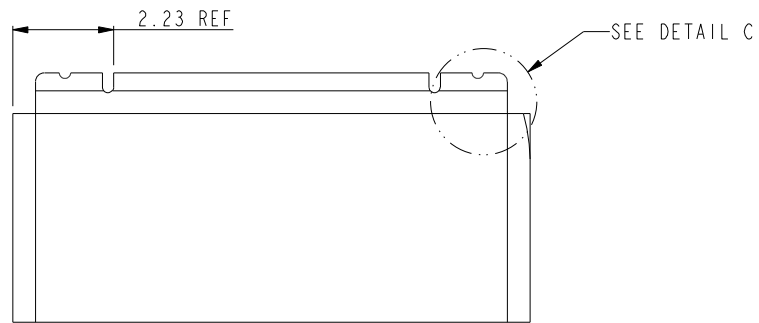

NOTE:
1. TOLERANCE FOR PCB LAYOUT: $\pm 0.05\text{MM}$.

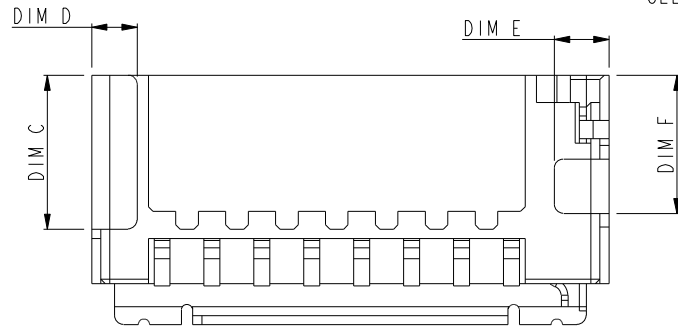
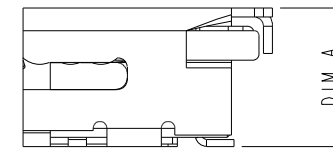
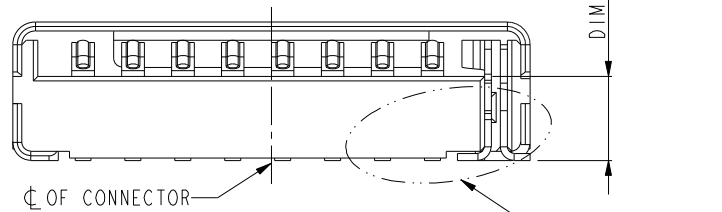
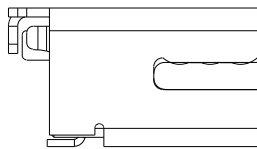

SCALE 6.000

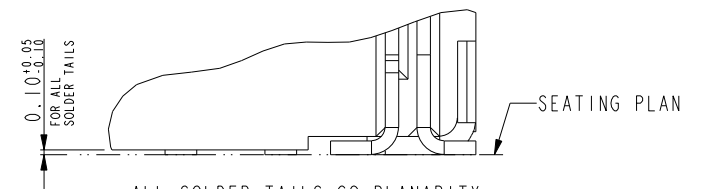

ALL SOLDER TAILS CO-PLANARITY
FROM SEATING PLANE: 0.08MM MAX.

DETAIL A
SCALE 12.000

FOR THE OTHER DIMENSIONS
ARE THE SAME AS -100LF



Copyright FCI.

	title	TFLASH CONNECTOR ASSEMBLY	dwg no	10067099	Rev.	G
		TFLASH CONNECTOR WITH CARD DETECTING				
	catalog no	10067099	CUSTOMER	sheet 3 of 3		