



Chipsmall Limited consists of a professional team with an average of over 10 year of expertise in the distribution of electronic components. Based in Hongkong, we have already established firm and mutual-benefit business relationships with customers from,Europe,America and south Asia,supplying obsolete and hard-to-find components to meet their specific needs.

With the principle of “Quality Parts,Customers Priority,Honest Operation,and Considerate Service”,our business mainly focus on the distribution of electronic components. Line cards we deal with include Microchip,ALPS,ROHM,Xilinx,Pulse,ON,Everlight and Freescale. Main products comprise IC,Modules,Potentiometer,IC Socket,Relay,Connector.Our parts cover such applications as commercial,industrial, and automotives areas.

We are looking forward to setting up business relationship with you and hope to provide you with the best service and solution. Let us make a better world for our industry!



Contact us

Tel: +86-755-8981 8866 Fax: +86-755-8427 6832

Email & Skype: info@chipsmall.com Web: www.chipsmall.com

Address: A1208, Overseas Decoration Building, #122 Zhenhua RD., Futian, Shenzhen, China



FCI CONFIDENTIAL

FCI
FCIconnect.com

This document is the property of and embodies CONFIDENTIAL and PROPRIETARY information of FCI. No part of this information shown on this document may be used in any way or disclosed to others without the written consent of FCI.
Copyright FCI.

PRODUCT NO.
10074998-118MCALF/118MCASLF

- NOTES:
- MATERIAL
 - HEADER ASS'Y
 - HOUSING: HIGH TEMPERATURE THERMOPLASTIC UL94V-0 BLACK
 - PIN : COPPY ALLOY
 - PCB : FR4
 - FINISH (PIN)
 - UNDER PLATING : 0.5 um MIN. Ni
 - CONTACT AREA : 0.25 um MIN. GOLD
 - SOLDER TAIL: 2.5 um MIN. PURE TIN (FOR LEAD FREE OPTION)
 - STAND-OFF : 3 um MIN. Ni.
 - RECOMMENDED M2 SCREW LENGTH(): 5.0mm MIN.~15.0mm MAX.
 - IF LEAD FREE P.N.THE HOUSING WILL WITHSTAND EXPOSURE TO 260°C PEAK TEMPERATURE FOR 10 SECONDS IN A WAVE SOLDER APPLICATION WITH A 1.00MM MINIMUM THICK CIRCUIT BOARD.
 - IF LEAD FREE P/N.THE PRODUCT MEETS EUROPEAN UNION DIRECTIVES AND OTHER COUNTRY REGULATIONS AS DESCRIBED IN GS-22-008
 - LEAD FREE P/N PACKAGING MEETS GS-14-920 SPECIFICATION
 - 10074998-118MCASLF WITH BOTTOM SHIELD
 - 10074998-118MCALF WITHOUT BOTTOM SHIELD
 - PRODUCT SPEC:110-263

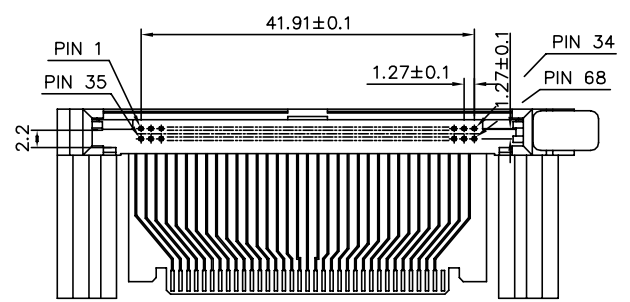
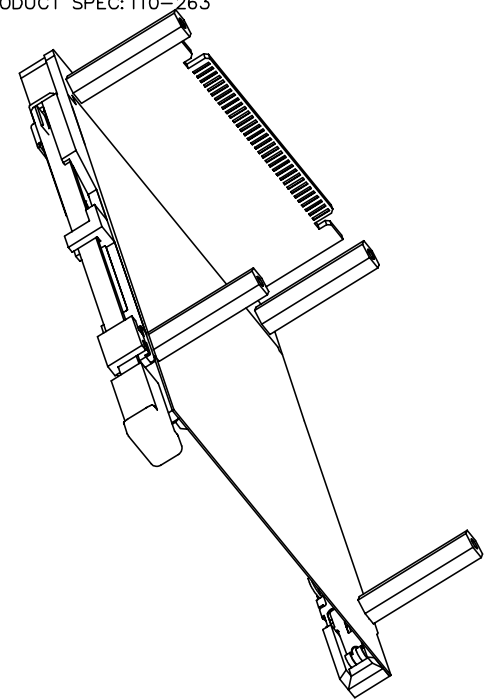
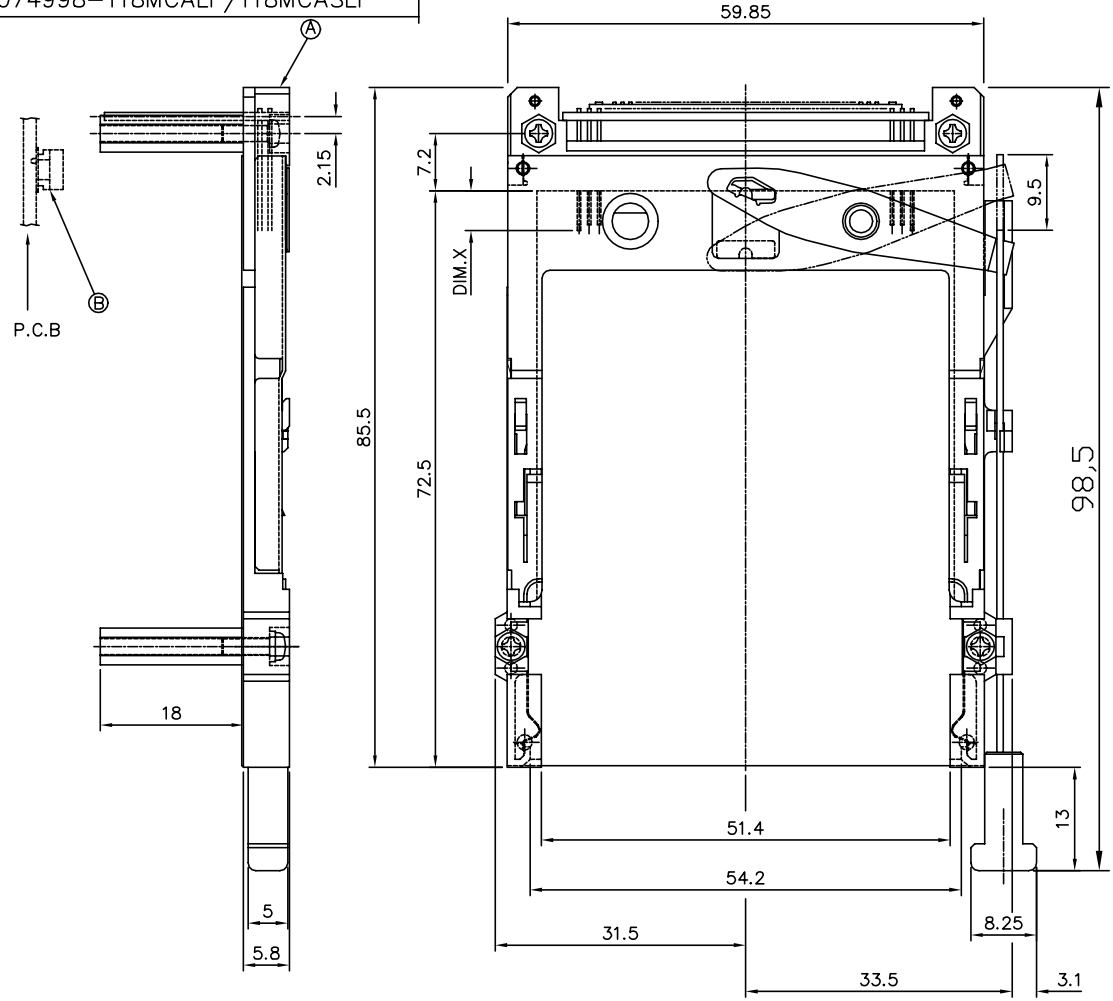

mat'l. code		surface	tolerance	projection	product family
		ISO 1302	ISO 406 ISO 1101		PCMCIA
ltr	ecn	no	dr	date	tolerances unless otherwise specified
A	N06-0308	DT		12/11/06	angles .X±.3
B	N07-0002	MZ		07/07/07	linear .XX±.13
C	N07-0167	MSH		07/19/07	±2' .XXX±.051
D	ELX-N-011455	ZK	04/25/12	dr Daniel Tao	12/7/06
E	ELX-N-011826	ZK	06/01/12	engr Daniel Tao	12/7/06
				chr David Qin	12/7/06
				app Jack Wang	12/7/06
sheet		revision	E		
index		sheet	1		



68 POS EJECTOR HEADER ASSY
(FOR 3.3V APPLICATION)

dwg no 10074998 sheet 1 of 1 size A4

type CUSTOMER Drawing