



Chipsmall Limited consists of a professional team with an average of over 10 year of expertise in the distribution of electronic components. Based in Hongkong, we have already established firm and mutual-benefit business relationships with customers from,Europe,America and south Asia,supplying obsolete and hard-to-find components to meet their specific needs.

With the principle of “Quality Parts,Customers Priority,Honest Operation,and Considerate Service”,our business mainly focus on the distribution of electronic components. Line cards we deal with include Microchip,ALPS,ROHM,Xilinx,Pulse,ON,Everlight and Freescale. Main products comprise IC,Modules,Potentiometer,IC Socket,Relay,Connector.Our parts cover such applications as commercial,industrial, and automotives areas.

We are looking forward to setting up business relationship with you and hope to provide you with the best service and solution. Let us make a better world for our industry!



Contact us

Tel: +86-755-8981 8866 Fax: +86-755-8427 6832

Email & Skype: info@chipsmall.com Web: www.chipsmall.com

Address: A1208, Overseas Decoration Building, #122 Zhenhua RD., Futian, Shenzhen, China



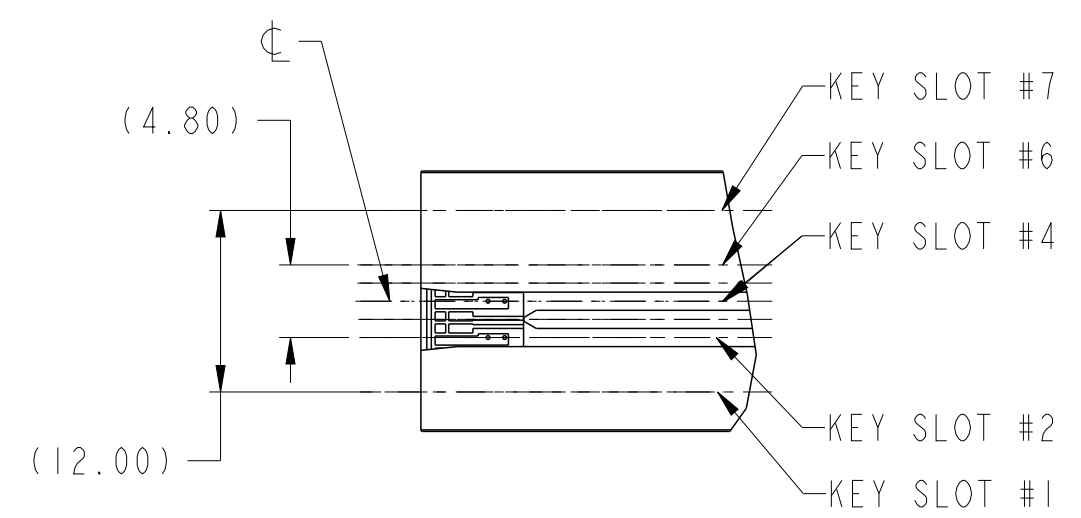
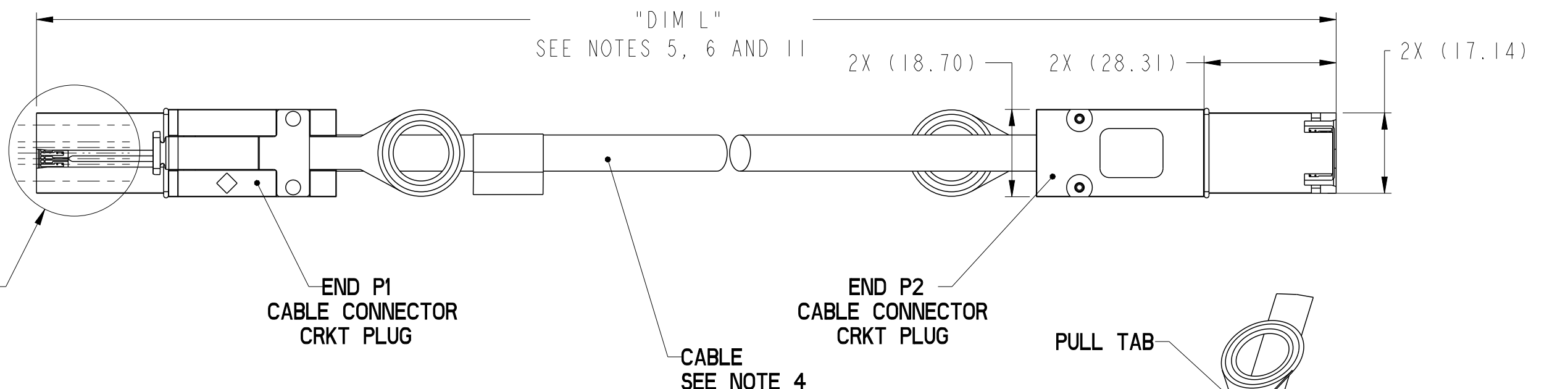
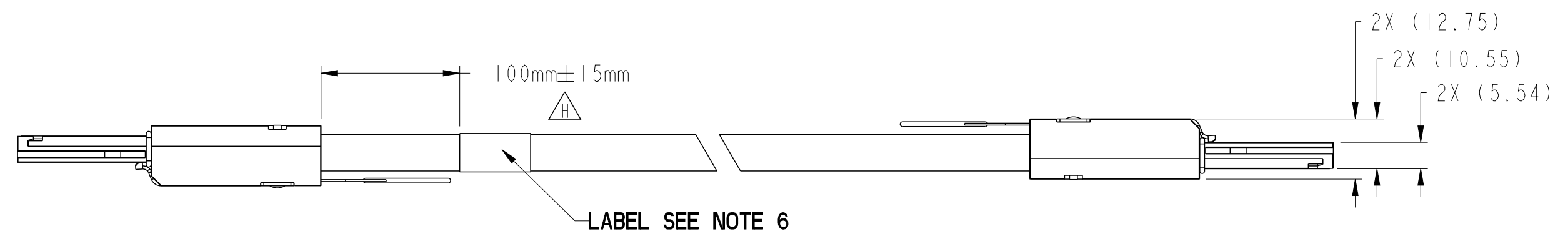

DETAIL A
KEY SLOTS #2 & #4 SHOWN
SCALE 2:1

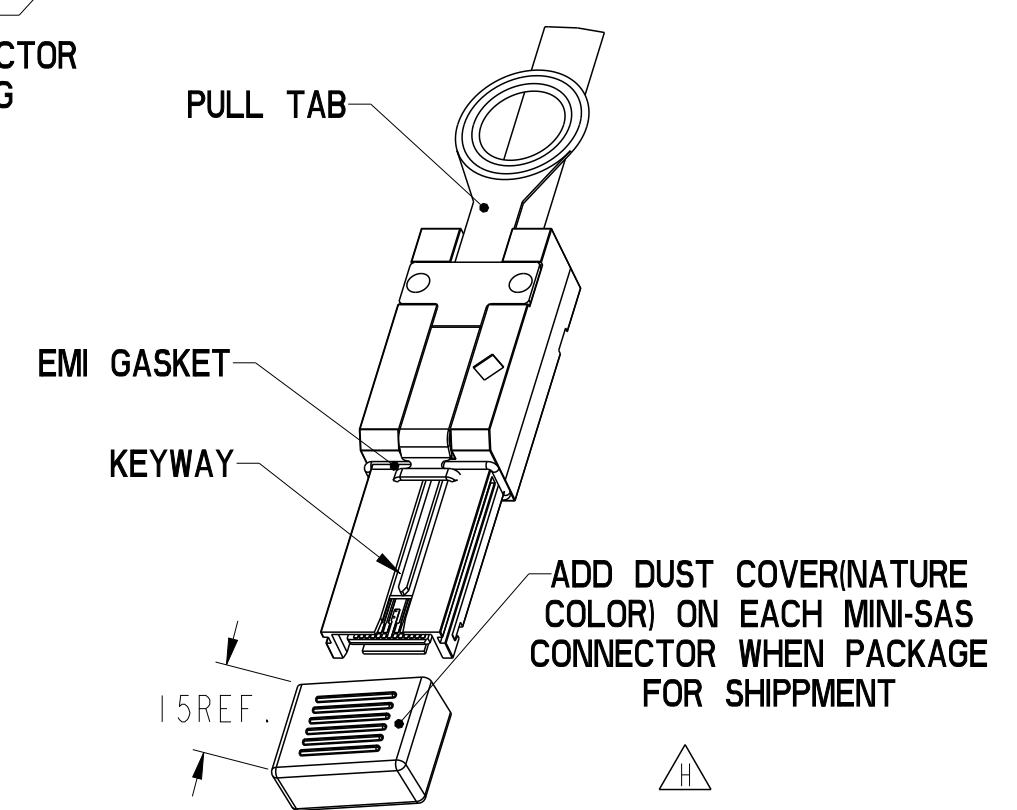

spec ref	---	dr	Stu Stoner	2008/02/05	projection	MM	size	A3	scale	1:1
tolerance std	---	eng	Tom Feng	2014/09/24			ecn no	ELX-N-18883-1	rel level	Released
---	TOLERANCES UNLESS OTHERWISE SPECIFIED	chr	-	-						
surface	✓	appr	Delhy Liu	2014/09/24			title FINAL CABLE ASSEMBLY-ALTERNATE CABLE Mini SAS 2.0/SATA (CRKT)		dwg no 10084749	rev H
---	linear	0.X	±0.3	www.fci.com	cat. no.	-	Product - Customer Drw	sheet 1 of 6		
---	angular	0°	±2°							

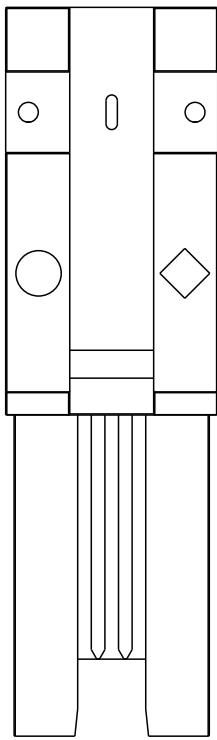

KEY SLOT 2, 4 & 6
 ○ ◇ UNIVERSIAL PORT

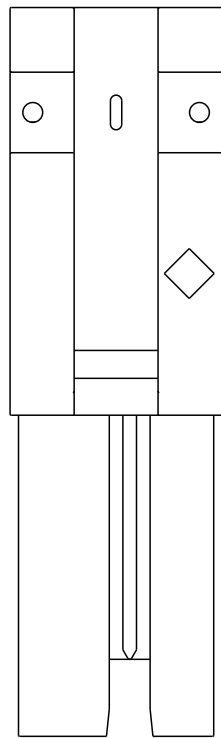

KEY SLOT 2 & 4
 ◇ OUT PORT

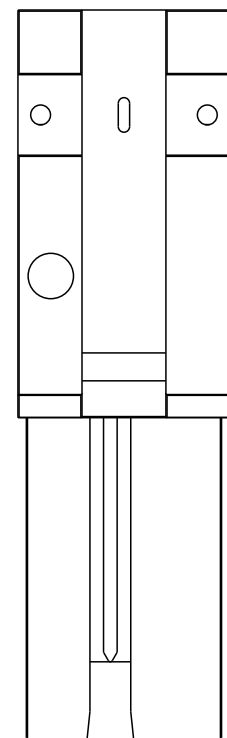

KEY SLOT 4 & 6
 ○ IN PORT

MINI SAS 2.0

PRODUCT NUMBER SEE NOTE 4	HUAWEI PART NUMBER	DESCRIPTION	GAUGE	"DIM L" LENGTH	END P1 KEY SLOT	END P2 KEY SLOT	IDENTIFIER
I0084749-M060002LF	/	X4 SAS CABLE ASSEMBLY	24 AWG	6M	4, 6	4, 6	SUBTRACTIVE ROUTING (IN PORT), SAS
I0084749-N040002LF	/	X4 SAS CABLE ASSEMBLY	26 AWG	4M	4, 6	4, 6	
I0084749-N050002LF	/	X4 SAS CABLE ASSEMBLY	26 AWG	5M	4, 6	4, 6	
I0084749-P010002LF	/	X4 SAS CABLE ASSEMBLY	28 AWG	1M	4, 6	4, 6	
I0084749-P020002LF	/	X4 SAS CABLE ASSEMBLY	28 AWG	2M	4, 6	4, 6	
I0084749-P030002LF	/	X4 SAS CABLE ASSEMBLY	28 AWG	3M	4, 6	4, 6	
I0084749-M060003LF	/	X4 SAS CABLE ASSEMBLY	24 AWG	6M	2, 4, 6	2, 4, 6	UNIVERSAL KEY, SAS
I0084749-N030003LF	/	X4 SAS CABLE ASSEMBLY	26 AWG	3M	2, 4, 6	2, 4, 6	
I0084749-N040003LF	/	X4 SAS CABLE ASSEMBLY	26 AWG	4M	2, 4, 6	2, 4, 6	
I0084749-N050003LF	/	X4 SAS CABLE ASSEMBLY	26 AWG	5M	2, 4, 6	2, 4, 6	
I0084749-P002503LF	/	X4 SAS CABLE ASSEMBLY	28 AWG	0.25M	2, 4, 6	2, 4, 6	
I0084749-P010003LF	/	X4 SAS CABLE ASSEMBLY	28 AWG	1M	2, 4, 6	2, 4, 6	
I0084749-P015003LF	/	X4 SAS CABLE ASSEMBLY	28 AWG	1.5M	2, 4, 6	2, 4, 6	
I0084749-P020003LF	/	X4 SAS CABLE ASSEMBLY	28 AWG	2M	2, 4, 6	2, 4, 6	
I0084749-P025003LF	/	X4 SAS CABLE ASSEMBLY	28 AWG	2.5M	2, 4, 6	2, 4, 6	
I0084749-P030003LF	/	X4 SAS CABLE ASSEMBLY	28 AWG	3M	2, 4, 6	2, 4, 6	
I0084749-M060006LF	/	X4 SAS CABLE ASSEMBLY	24 AWG	6M	2, 4	4, 6	SAS, TABLE ROUTING (OUT PORT), TO SUBTRACTIVE ROUTING (IN PORT)
I0084749-N010006LF	/	X4 SAS CABLE ASSEMBLY	26 AWG	1M	2, 4	4, 6	
I0084749-N030006LF	/	X4 SAS CABLE ASSEMBLY	26 AWG	3M	2, 4	4, 6	
I0084749-N040006LF	/	X4 SAS CABLE ASSEMBLY	26 AWG	4M	2, 4	4, 6	
I0084749-N050006LF	/	X4 SAS CABLE ASSEMBLY	26 AWG	5M	2, 4	4, 6	
I0084749-P010006LF	0405G005	X4 SAS CABLE ASSEMBLY	28 AWG	1M	2, 4	4, 6	
I0084749-P020006LF	/	X4 SAS CABLE ASSEMBLY	28 AWG	2M	2, 4	4, 6	
I0084749-P030006LF	0405G003	X4 SAS CABLE ASSEMBLY	28 AWG	3M	2, 4	4, 6	

MINI SAS 2.0 KEYING OPTIONS

spec ref	---	dr	Stu Stoner	2008/02/05	projection	MM	size	A3	scale	1:1	
tolerance std	---	eng	Tom Feng	2014/09/24			ecn no	ELX-N-18883-1	rel level	Released	
---	TOLERANCES UNLESS OTHERWISE SPECIFIED	chr	-	-							
surface	✓	appr	Delhy Liu	2014/09/24	product family	MiniSAS/SATA	dwg no		10084749	rev	H
linear	0.X ±0.3	www.fci.com		cat. no.	-	Product - Customer Drw	sheet 2 of 6				
linear	0.XX ±0.10										
linear	0.XXX ±0.050										
angular	0° ±2°										

SATA

PRODUCT NUMBER SEE NOTE 4	DESCRIPTION	GAUGE	"DIM L" LENGTH	END P1 KEY SLOT	END P2 KEY SLOT	IDENTIFIER
10084749-M060004LF	X4 SATA CABLE ASSEMBLY	24 AWG	6M	1,4	1,4	X CABLE, SATA
10084749-N020004LF	X4 SATA CABLE ASSEMBLY	26 AWG	2M	1,4	1,4	
10084749-N040004LF	X4 SATA CABLE ASSEMBLY	26 AWG	4M	1,4	1,4	
10084749-N050004LF	X4 SATA CABLE ASSEMBLY	26 AWG	5M	1,4	1,4	
10084749-P010004LF	X4 SATA CABLE ASSEMBLY	28 AWG	1M	1,4	1,4	
10084749-P030004LF	X4 SATA CABLE ASSEMBLY	28 AWG	3M	1,4	1,4	
10084749-M060005LF	X4 SATA CABLE ASSEMBLY	24 AWG	6M	7	7	M CABLE, SATA
10084749-N020005LF	X4 SATA CABLE ASSEMBLY	26 AWG	2M	7	7	
10084749-N040005LF	X4 SATA CABLE ASSEMBLY	26 AWG	4M	7	7	
10084749-N050005LF	X4 SATA CABLE ASSEMBLY	26 AWG	5M	7	7	
10084749-P010005LF	X4 SATA CABLE ASSEMBLY	28 AWG	1M	7	7	
10084749-P030005LF	X4 SATA CABLE ASSEMBLY	28 AWG	3M	7	7	

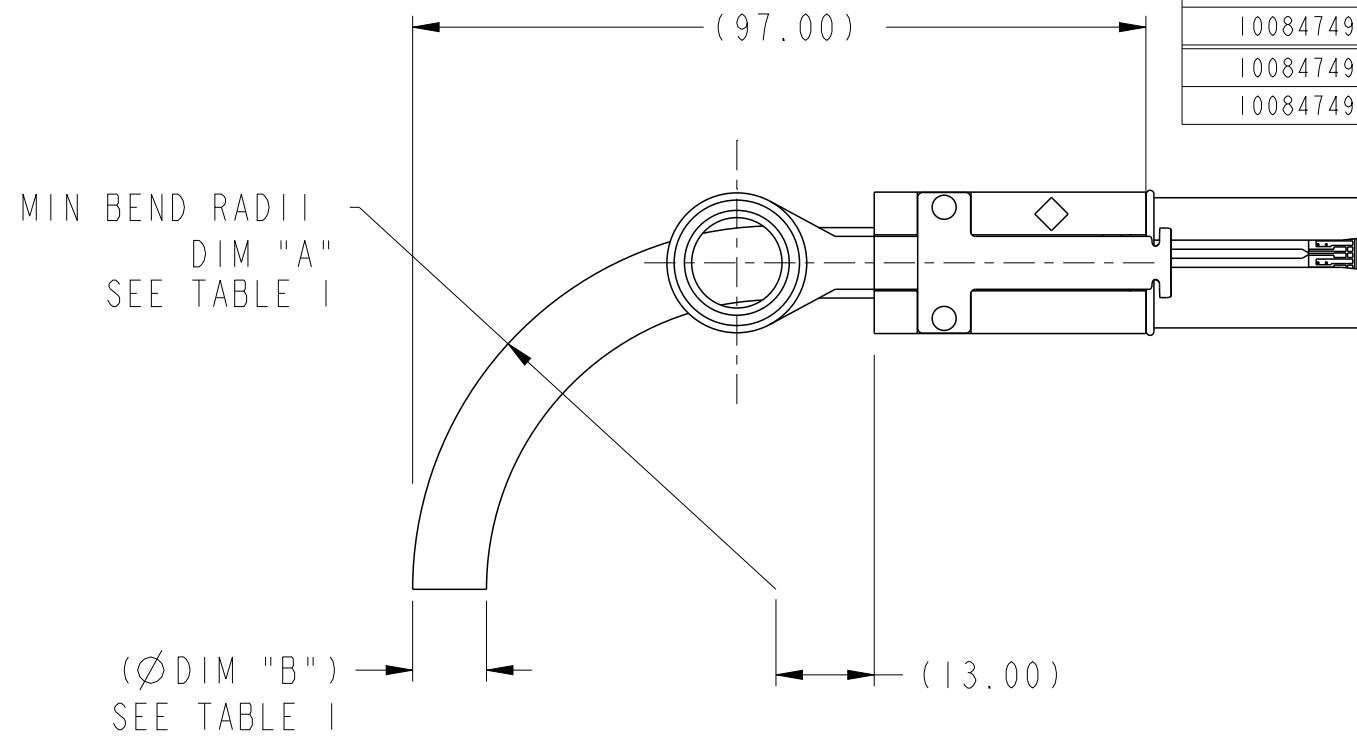

**BEND RADIUS
(24 AWG SHOWN)**

CABLE	DIM "A"	DIM "B"
24 AWG	(R46.9)	(Ø 9.5mm)
26 AWG	(R41.7)	(Ø 8.3mm)
28 AWG	(R37.7)	(Ø 7.6mm)

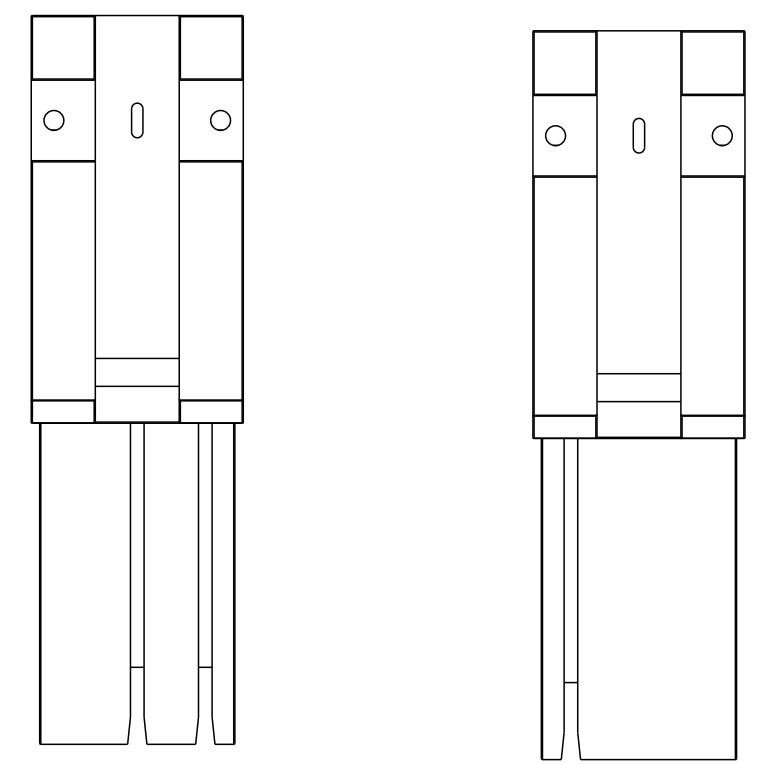

SATA KEYING OPTIONS

spec ref	---	dr	Stu Stoner	2008/02/05	projection	MM	size	A3	scale	1:1
tolerance std	---	eng	Tom Feng	2014/09/24			ecn no	ELX-N-18883-1	rel level	Released
---	TOLERANCES UNLESS OTHERWISE SPECIFIED	chr	-	-						
surface	✓	appr	Delhly Liu	2014/09/24	product family	MiniSAS/SATA	rel level	Released	rev	H
---	linear	0.X	±0.3		title FINAL CABLE ASSEMBLY-ALTERNATE CABLE Mini SAS 2.0/SATA (CRKT)	dwg no 10084749	cat. no. -	Product - Customer Drw	sheet 3 of 6	angular 0° ±2°
---	0.XX	±0.10								
---	0.XXX	±0.050								



Copyright FCI.

A

B

C

D

A

B

C

D

WIRING LIST SEE NOTE 7

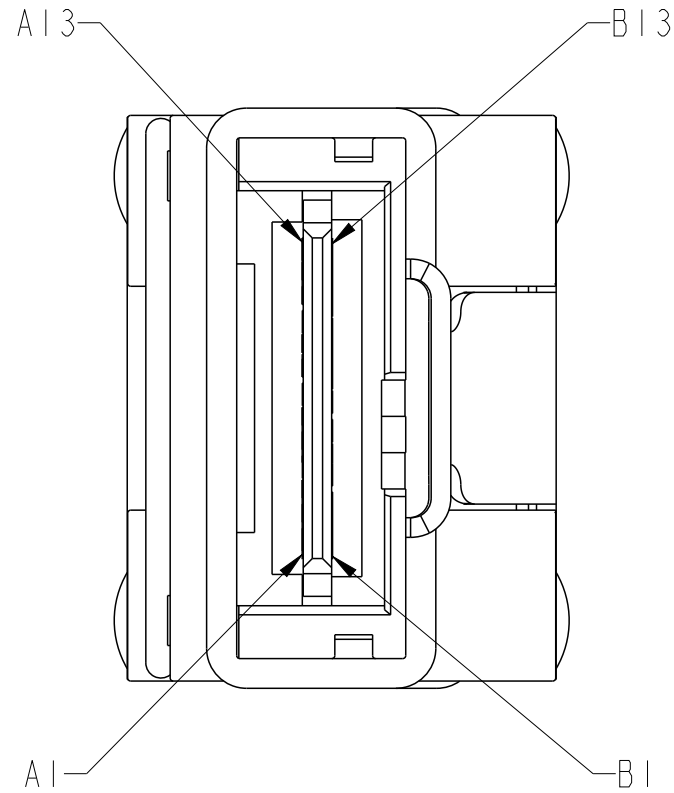

	GND	A1	---	B1	GND
	Rx 0+	A2	←	B2	Tx 0+
	Rx 0-	A3	←	B3	Tx 0-
	GND	A4	---	B4	GND
	Rx 1+	A5	←	B5	Tx 1+
	Rx 1-	A6	←	B6	Tx 1-
	GND	A7	---	B7	GND
	Rx 2+	A8	←	B8	Tx 2+
	Rx 2-	A9	←	B9	Tx 2-
	GND	A10	---	B10	GND
	Rx 3+	A11	←	B11	Tx 3+
	Rx 3-	A12	←	B12	Tx 3-
	GND	A13	---	B13	GND
P1	GND	B1	---	A1	GND
	Tx 0+	B2	→	A2	Rx 0+
	Tx 0-	B3	→	A3	Rx 0-
	GND	B4	---	A4	GND
	Tx 1+	B5	→	A5	Rx 1+
	Tx 1-	B6	→	A6	Rx 1-
	GND	B7	---	A7	GND
	Tx 2+	B8	→	A8	Rx 2+
	Tx 2-	B9	→	A9	Rx 2-
	GND	B10	---	A10	GND
	Tx 3+	B11	→	A11	Rx 3+
	Tx 3-	B12	→	A12	Rx 3-
	GND	B13	---	A13	GND
					P2



Copyright FCI.

spec ref	---	dr	Stu Stoner	2008/02/05	projection	MM	size	A3	scale	1:1
tolerance std	---	eng	Tom Feng	2014/09/24			ecn no	ELX-N-18883-1	rel level	Released
---	TOLERANCES UNLESS OTHERWISE SPECIFIED	chr	-	-						
surface	✓	appr	Delhy Liu	2014/09/24	product family	MiniSAS/SATA				
linear	0.X ±0.3			title FINAL CABLE ASSEMBLY-ALTERNATE CABLE Mini SAS 2.0/SATA (CRKT)		dwg no 10084749		rev H		
	0.XX ±0.10									
	0.XXX ±0.050									
angular	0° ±2°	www.fci.com	cat. no.	-	Product - Customer Drw		sheet 4 of 6			

NOTES:

- ① - MATERIAL:
 BACK SHELLS: ZINC DIECAST
 PULL TAB: MOLDED THERMOPLASTIC
 LATCH: STAINLESS STEEL
 JET MELT: POLYAMIDE POLYMER
- 2 - ELECTRICAL PERFORMANCE PER CURRENT REVISION
 OF SERIAL ATA, T10/I760-D (SAS-2 REQUIREMENTS).
- ③ - THIS PRODUCT MEETS THE RESTRICTION OF HAZARDOUS SUBSTANCES IN
 ELECTRICAL AND ELECTRONIC EQUIPMENT (RoHS) DIRECTIVE (2002/95/EC)

4 - PART NUMBER DESCRIPTION

10084749 - X XX XX XX LF

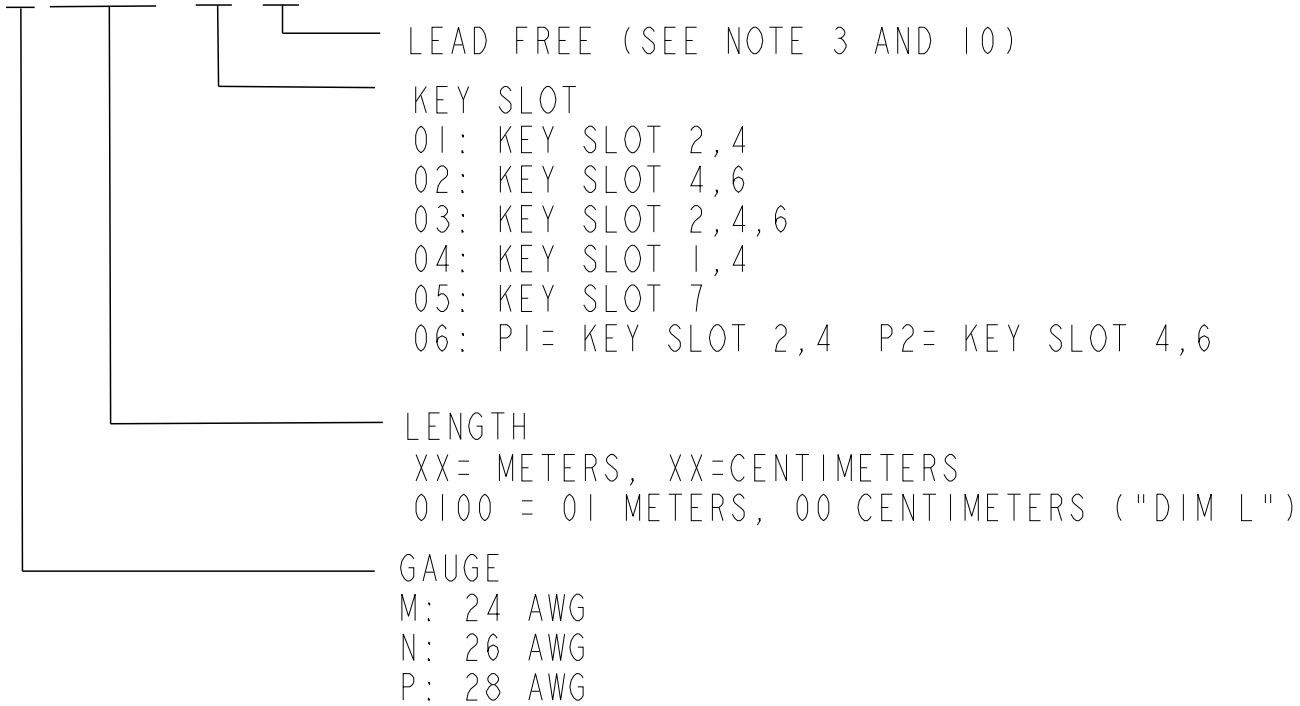

- ⑤ - UNLESS OTHERWISE SPECIFIED ASSEMBLED LENGTH TOLERANCE IS TO BE:
 < 1 METER = $\pm 25.0\text{mm}$
 > 1 METER TO 6 METERS = $\pm 2\%$ OF "DIM L"

spec ref	---	dr	Stu Stoner	2008/02/05	projection	MM	size	A3	scale	1:1
tolerance std	---	eng	Tom Feng	2014/09/24		← →	ecn no	ELX-N-18883-1		
---	TOLERANCES UNLESS OTHERWISE SPECIFIED	chr	-	-			product family	MiniSAS/SATA	rel level	Released
surface	✓	appr	Delhy Liu	2014/09/24	www.fci.com		title	FINAL CABLE ASSEMBLY-ALTERNATE CABLE	dwg no	10084749
---	linear	0.X	± 0.3		Mini SAS 2.0/SATA (CRKT)		rev	H		
		0.XX	± 0.10		cat. no.	-	Product - Customer Drw	sheet 5 of 6		
	angular	0°	$\pm 2^\circ$		PDS: Rev :H		STATUS:Released		Printed: Sep 24, 2014	

NOTES CONTINUED:

- ⑥ - UNLESS OTHERWISE SPECIFIED LABEL POSITION IS TO BE 100mm FROM REAR OF CONNECTOR.
LABEL DETAILS:

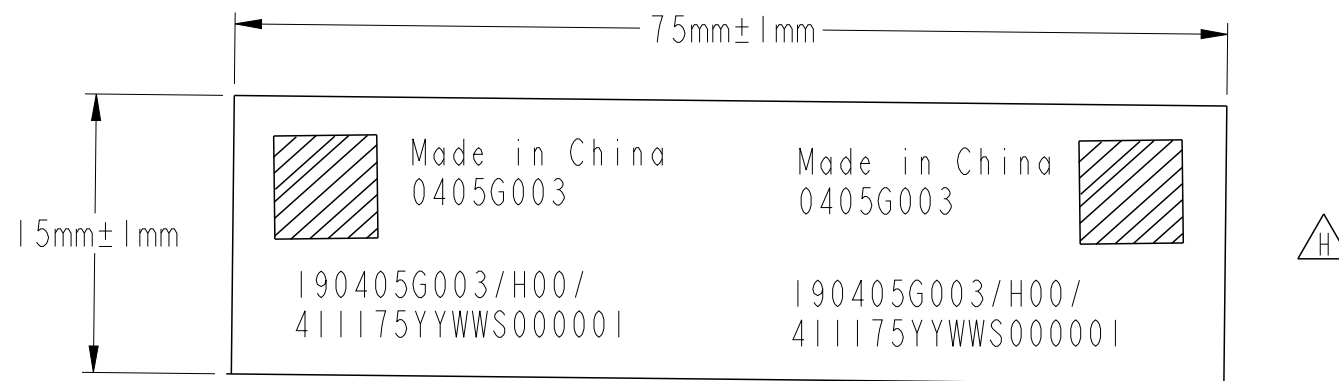

FONT SHALL BE CLEARLY VISIBLE AND BLACK IN COLOR.

- ⑦ - ALL CABLE ASSEMBLIES SHALL BE 100% TESTED FOR CONTINUITY AS DEFINED IN WIRING LIST.
- ⑧ - UNLESS OTHERWISE SPECIFIED ALL CABLE ASSEMBLIES SHALL BE 100% HI-POT TESTED BY APPLYING 300V DC FOR A MINIMUM OF 10ms, UNLESS ACTIVE COMPONENTS ARE USED IN THIS ASSEMBLY.
- 9 - OTHER TESTING PERFORMED AS REQUIRED BY PRODUCT SPECIFICATION: GS-12-548.
- 10 - PACKAGING OF LEAD FREE PRODUCTS MEETS LABELING AND PACKAGING PER SPECIFICATION GS-14-920. PACKAGE CABLE ASSEMBLIES PER GS-14-1272. ADD DUST COVER ON MINI-SAS CONNECTOR WHEN PACKAGE FOR SHIPPMENT NEED STICK BELOW LABEL ON PE BAG.

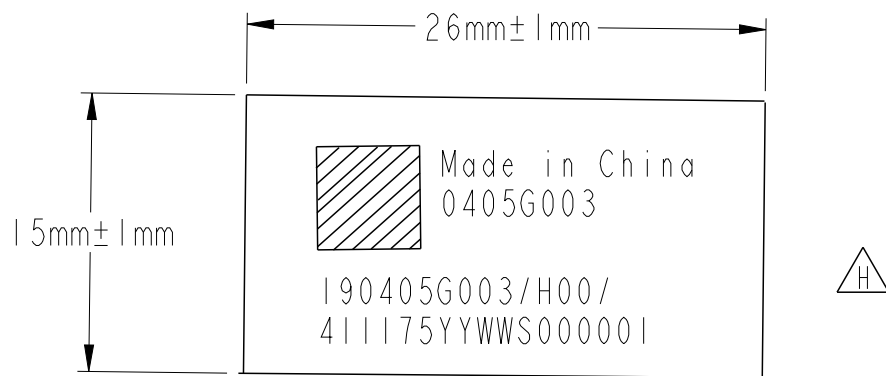

11. THIS DIMENSION IS A FINISHED PRODUCT LENGTH.

12. A "△" SYMBOL WILL BE NEXT TO ANY DIMENSION, VIEW, OR NOTE WHICH HAS BEEN MODIFIED WITH THE CURRENT DRAWING REVISION. THE CURRENT REVISION WILL BE SHOWN IN THE SYMBOL.

spec ref	---	dr	Stu Stoner	2008/02/05	projection	MM	size	A3	scale	1:1				
tolerance std	TOLERANCES UNLESS OTHERWISE SPECIFIED	eng	Tom Feng	2014/09/24		←→	ecn no	ELX-N-18883-1						
---		chr	-	-				product family	MiniSAS/SATA	rel level	Released			
---		appr	Delhy Liu	2014/09/24	surface	linear	0.X				±0.3	FCj	title	FINAL CABLE ASSEMBLY-ALTERNATE CABLE
---	angular	0°	±2°	www.fci.com	cat. no.	-	Product - Customer Drw	sheet 6 of 6						



Copyright FCI.