



Chipsmall Limited consists of a professional team with an average of over 10 year of expertise in the distribution of electronic components. Based in Hongkong, we have already established firm and mutual-benefit business relationships with customers from,Europe,America and south Asia,supplying obsolete and hard-to-find components to meet their specific needs.

With the principle of “Quality Parts,Customers Priority,Honest Operation,and Considerate Service”,our business mainly focus on the distribution of electronic components. Line cards we deal with include Microchip,ALPS,ROHM,Xilinx,Pulse,ON,Everlight and Freescale. Main products comprise IC,Modules,Potentiometer,IC Socket,Relay,Connector.Our parts cover such applications as commercial,industrial, and automotives areas.

We are looking forward to setting up business relationship with you and hope to provide you with the best service and solution. Let us make a better world for our industry!



Contact us

Tel: +86-755-8981 8866 Fax: +86-755-8427 6832

Email & Skype: info@chipsmall.com Web: www.chipsmall.com

Address: A1208, Overseas Decoration Building, #122 Zhenhua RD., Futian, Shenzhen, China



10091836 - X 0 J - X X X L F

4-COLUMN DIFFERENTIAL SIGNAL

LEAD-FREE DESIGNATION ONLY WITH APPLICABLE PLATING CODES

LETTER	PERFORMANCE-BASED PLATING (SEE NOTE 2)	
	TARGET APPLICATION	LEAD FREE (LF)
B	TELCORDIA CO	NO
C	TELCORDIA UE	NO
D	TELCORDIA CO	YES
E	TELCORDIA UE	YES

NUMBER	PIN STYLE, HEIGHT
0	STANDARD GUIDE PIN MACHINED, 31.6mm
4	STANDARD GUIDE PIN MACHINED, 25.7mm

MODULE DESCRIPTION	LETTER DESIGNATION REPRESENTED IN DASH NUMBER										BASE MODULE
LEFT POLARIZING GUIDANCE MODULE (SEE SHEET 3)	J	A	B	C	D	E	F	G	H		
RIGHT POLARIZING GUIDANCE MODULE (SEE SHEET 4)	Y	P	Q	R	S	T	U	V	W		
OPEN MODULE (TWO WALL) (SEE SHEET 2)	0 (ZERO)										
LEFT WALL MODULE (SEE SHEET 5)	L										
RIGHT WALL MODULE (SEE SHEET 6)	M										
FOUR WALL MODULE (SEE SHEET 7)	1										

NUMBER	CONTACT MATING WIPE LENGTH		COMPLIANT PIN DRILL SIZE
	SIGNAL	WIDE GROUND	
1	2	4	Ø0.55 [0.0217"]
2	3	4	Ø0.55 [0.0217"]
3	2	4	Ø0.45 [0.0177"]
4	3	4	Ø0.45 [0.0177"]
5	2	3	Ø0.55 [0.0217"]
6	3	3	Ø0.55 [0.0217"]
7	2	3	Ø0.45 [0.0177"]
8	3	3	Ø0.45 [0.0177"]

	GROUNDED	UNGROUNDED
FINISHED	Ø2.35-2.55	Ø2.35-2.55
PAD	Ø5.50	N/A
PLATED	YES	NO
DRILL (mm/in)	2.58 / .1015	2.44 / .096

SCREW P/N	DESCRIPTION	BOARD THICKNESS
10091790-002LF	#2-56 X .375" PHILLIPS PANHEAD W/SQ CONICAL WASHER	1.60 - 5.00
10091790-003LF	#2-56 X .500" PHILLIPS PANHEAD W/SQ CONICAL WASHER	5.00 - 10.00

spec ref	SEE NOTES	dr	Jim Swain	2010/04/13	projection	MM	size	A2	scale	4:1	
tolerance std	ASME Y14.5	eng	Michael Song	2016/06/06	chr	Heaven Cen	2016/06/08	ecn no	ELX-DG-24191-1	rel level	Released
surface	linear	0.X	±0.2	0.XX	±0.10	0.XXX	±0.050	ASME Y14.5	angular	0°	±°
Amphenol FCI		MODULE ASSEMBLY		VERTICAL HEADER, 4-COLUMN, 4-PAIR		cat. no.	10091836	Product - Customer Draw		sheet 1 of 8	

OPEN (2-WALL) MODULE

SEE NOTE 8

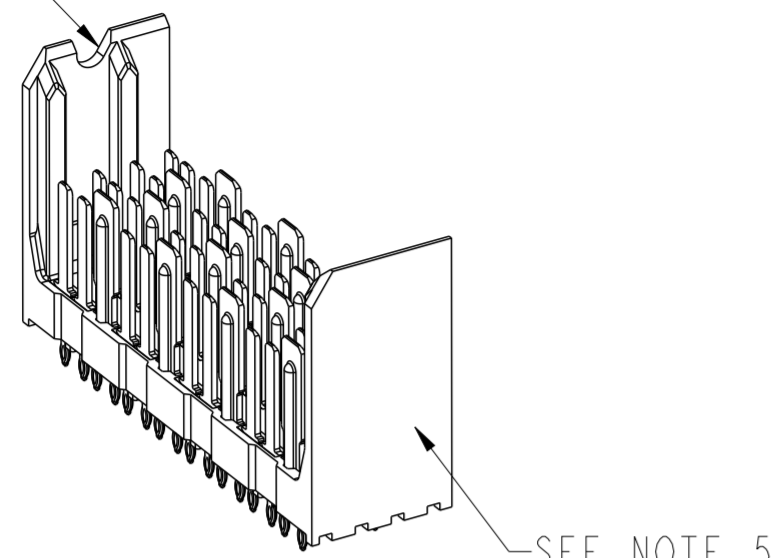

SEE NOTE 5

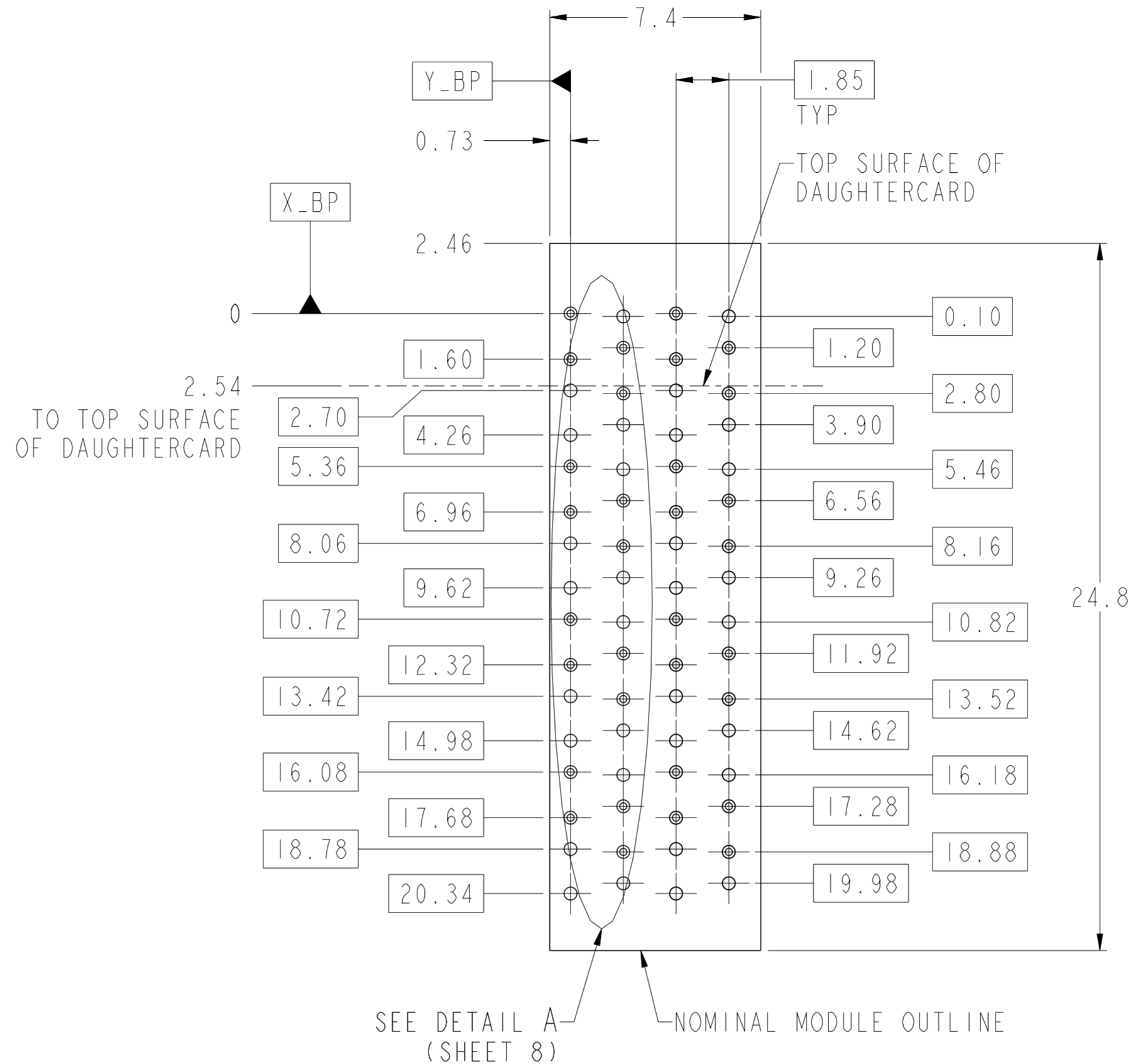
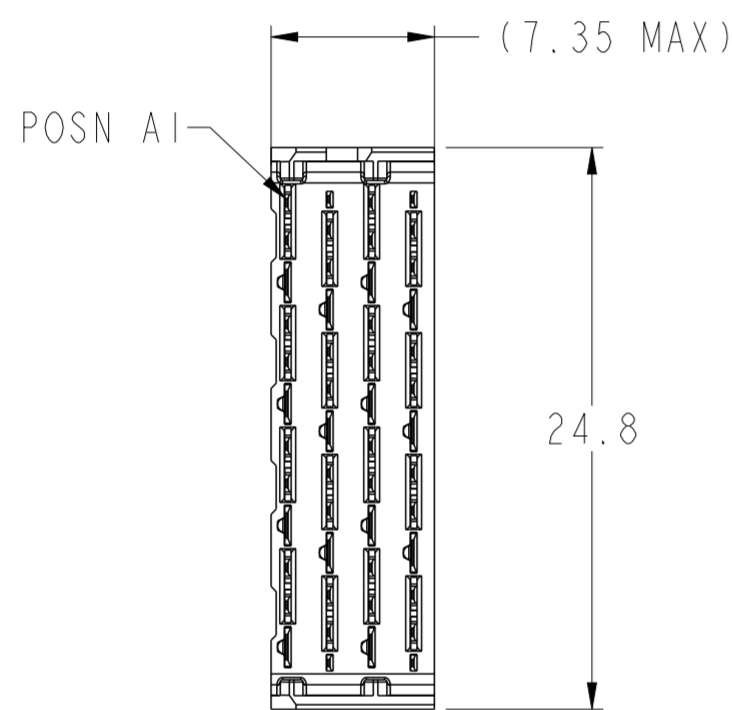

PCB HOLE PATTERN
COMPONENT SIDE
SCALE 6:1

- 6.2 (4MM WIPE WIDE GROUNDS)
- 5.2 (3MM WIPE WIDE GROUNDS)
- 5.2 (3MM SMALL END GROUNDS)
- 5.2 (3MM WIPE SIGNALS)
- 4.2 (2MM WIPE SIGNALS)
- SEE P/N TREE

2.64±0.10 FROM STANDOFF
SURFACE TO MATING SURFACE

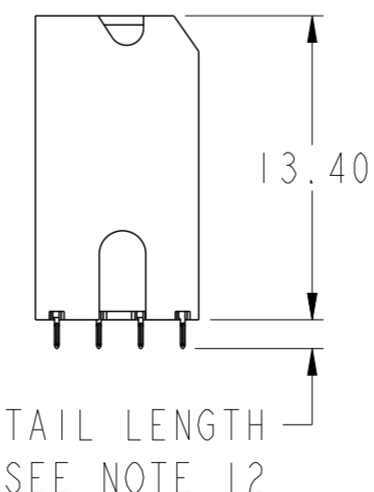
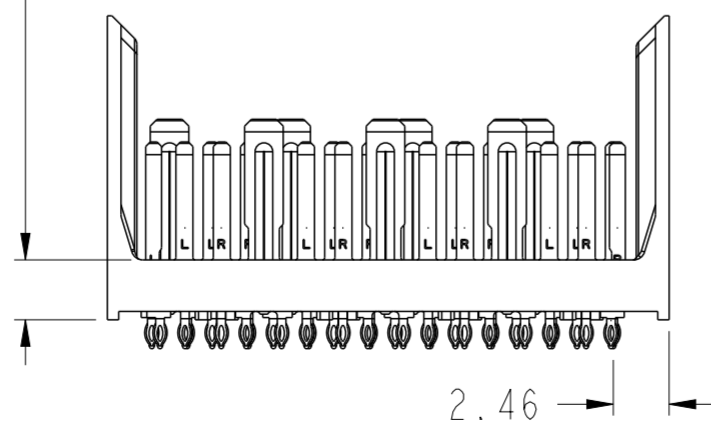
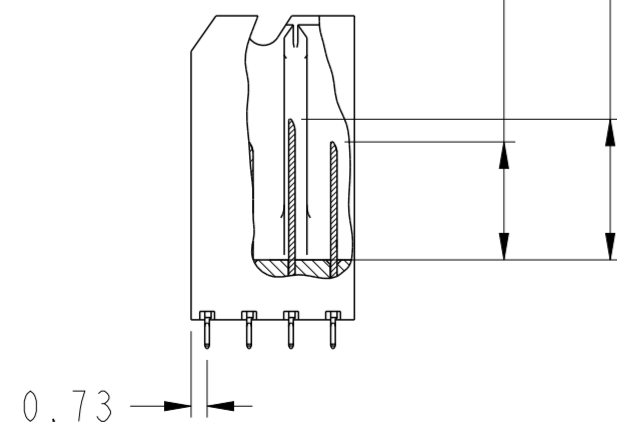

spec ref	SEE NOTES	dr	Jim Swain	2010/04/13	projection	MM	size	A2	scale	4:1
tolerance std	TOLERANCES UNLESS OTHERWISE SPECIFIED	eng	Michael Song	2016/06/06			ecn no	ELX-DG-24191-1		
ASME Y14.5		chr	Heaven Cen	2016/06/08				rel level	Released	
surface	linear	0.X	±0.2		MODULE ASSEMBLY VERTICAL HEADER, 4-COLUMN, 4-PAIR	cat. no.	Product - Customer Drw	sheet 2 of 8	rev G	
		0.XX	±0.10							
		0.XXX	±0.050							
ASME Y14.5	angular	0°	±°							

LEFT POLARIZING/GUIDE MODULE

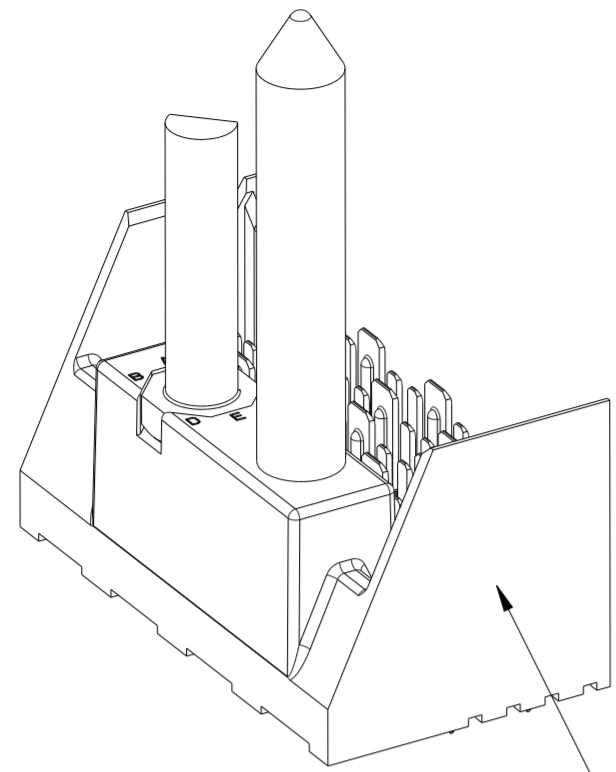

SEE NOTE 5

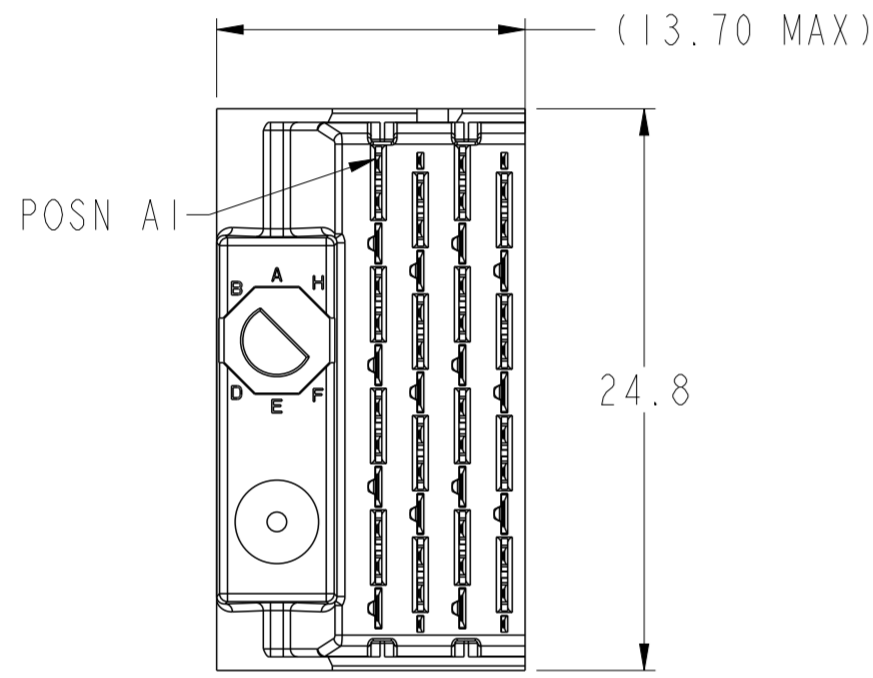

- 6.2 (4MM WIPE WIDE GROUNDS)
- 5.2 (3MM WIPE WIDE GROUNDS)
- 5.2 (3MM SMALL END GROUNDS)
- 5.2 (3MM WIPE SIGNALS)
- 4.2 (2MM WIPE SIGNALS)
- SEE P/N TREE

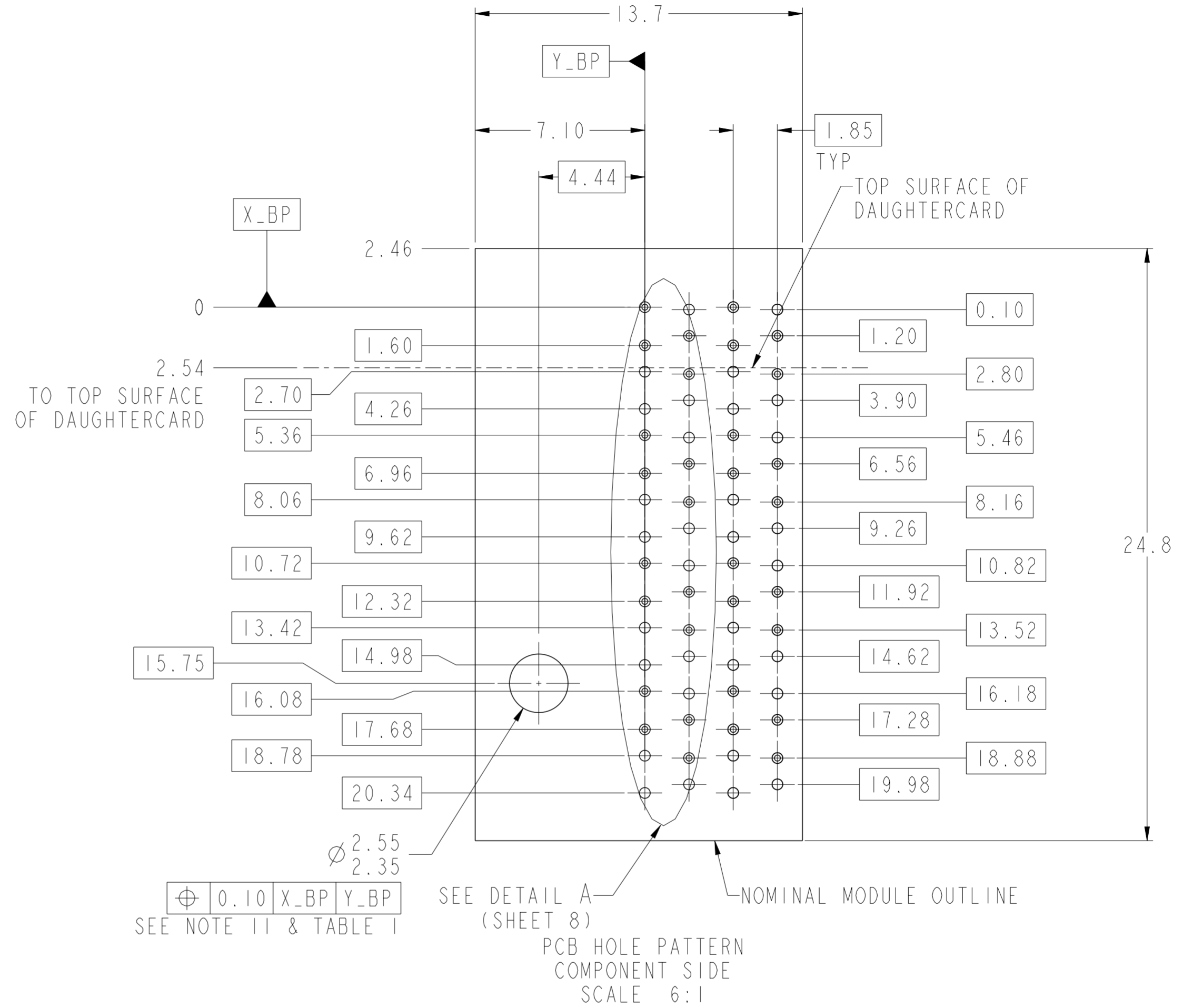
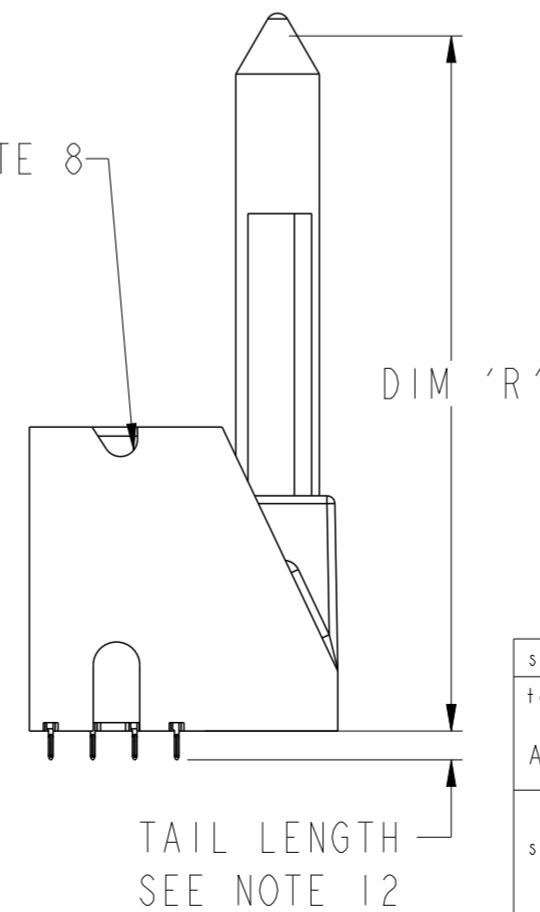
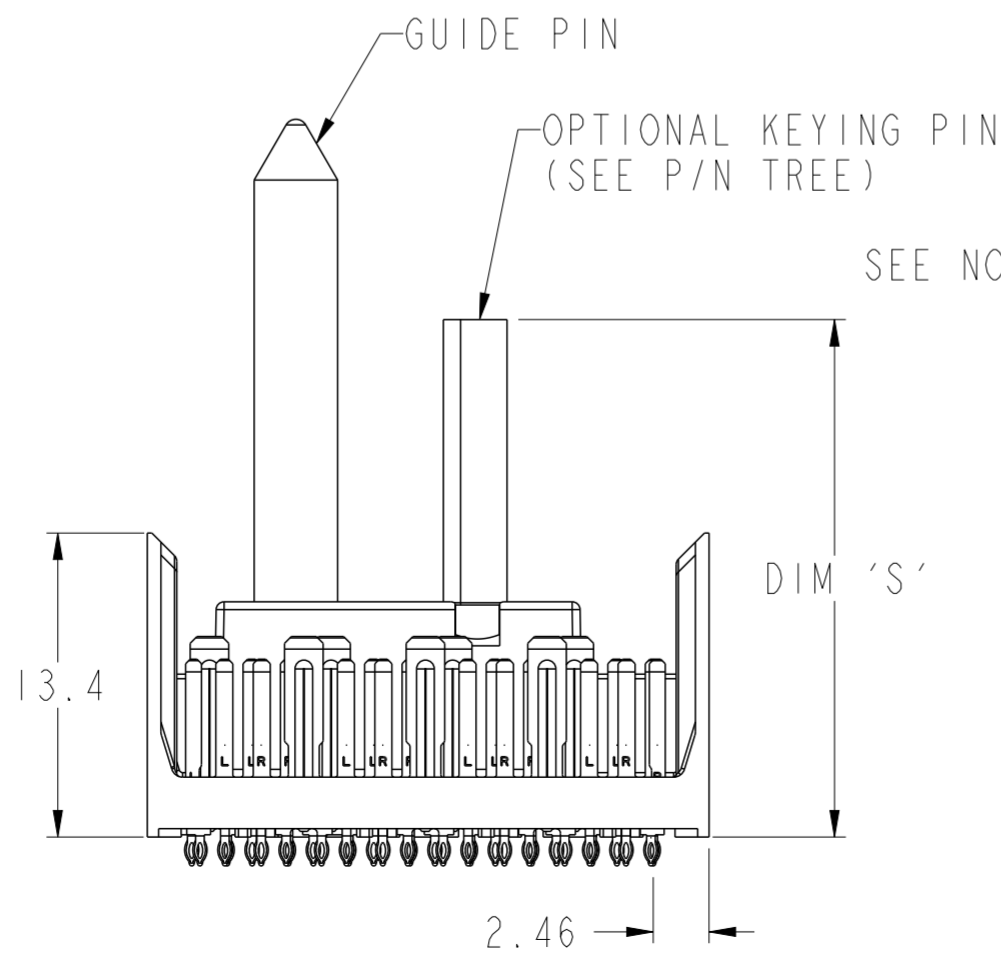
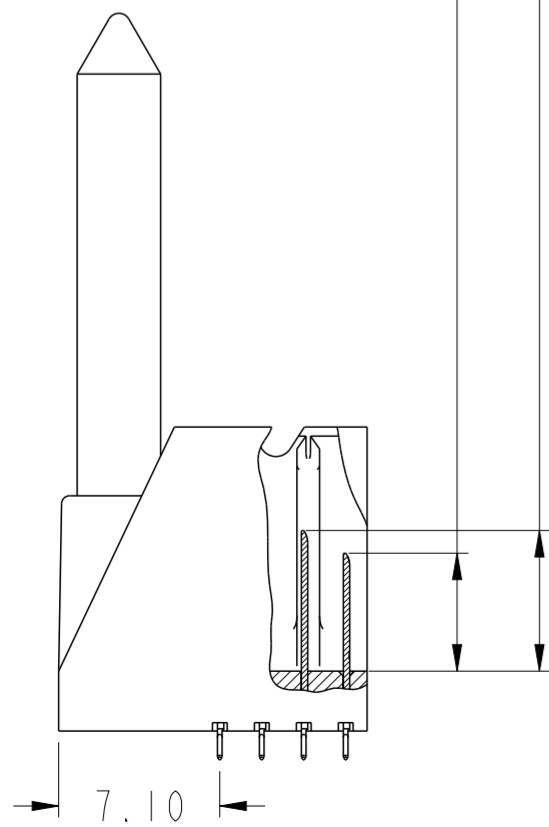

ASSEMBLY BASE CONFIGURATION END DASH NO.	GUIDE PIN	POLARIZING KEY
	DIM 'R'	DIM 'S'
-X0X	31.6mm	22.8mm
-X4X	25.7mm	20.0mm

spec ref	SEE NOTES	dr	Jim Swain	2010/04/13	projection	MM	size	A2	scale	3:1
tolerance std	TOLERANCES UNLESS OTHERWISE SPECIFIED	eng	Michael Song	2016/06/06			ecn no	ELX-DG-24191-1	rel level	Released
ASME Y14.5		chr	Heaven Cen	2016/06/08						
surface	linear	0.X	±0.2		MODULE ASSEMBLY VERTICAL HEADER, 4-COLUMN, 4-PAIR	cat. no. SEE P/N TREE	Product - Customer Drw	sheet 3 of 8	rev G	
		0.XX	±0.10							
ASME Y14.5	angular	0.XXX	±0.050							0°

RIGHT POLARIZING/GUIDE MODULE

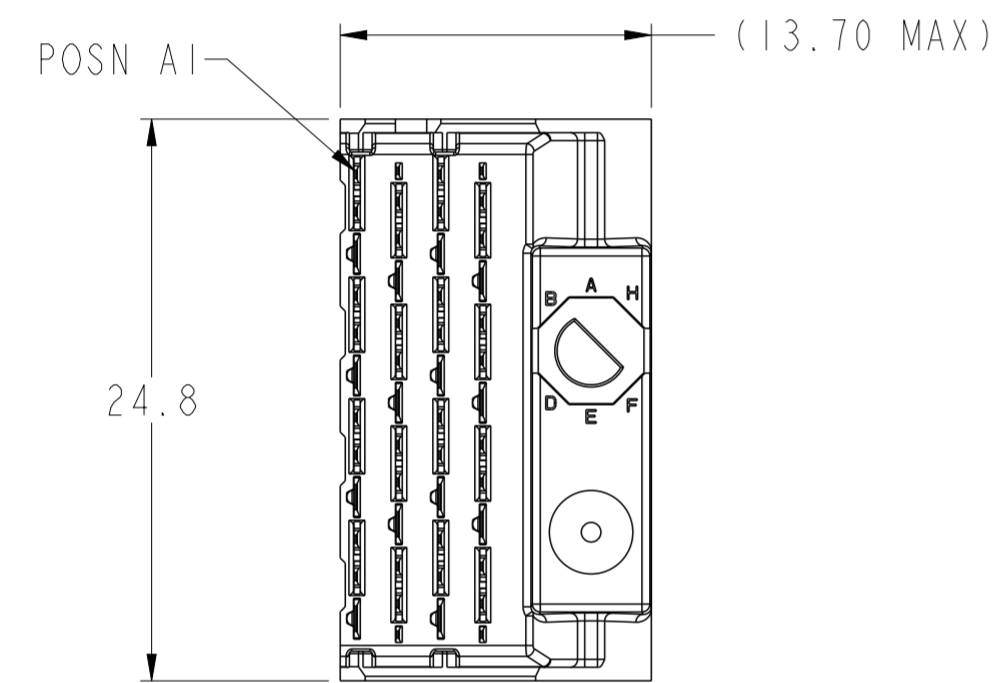
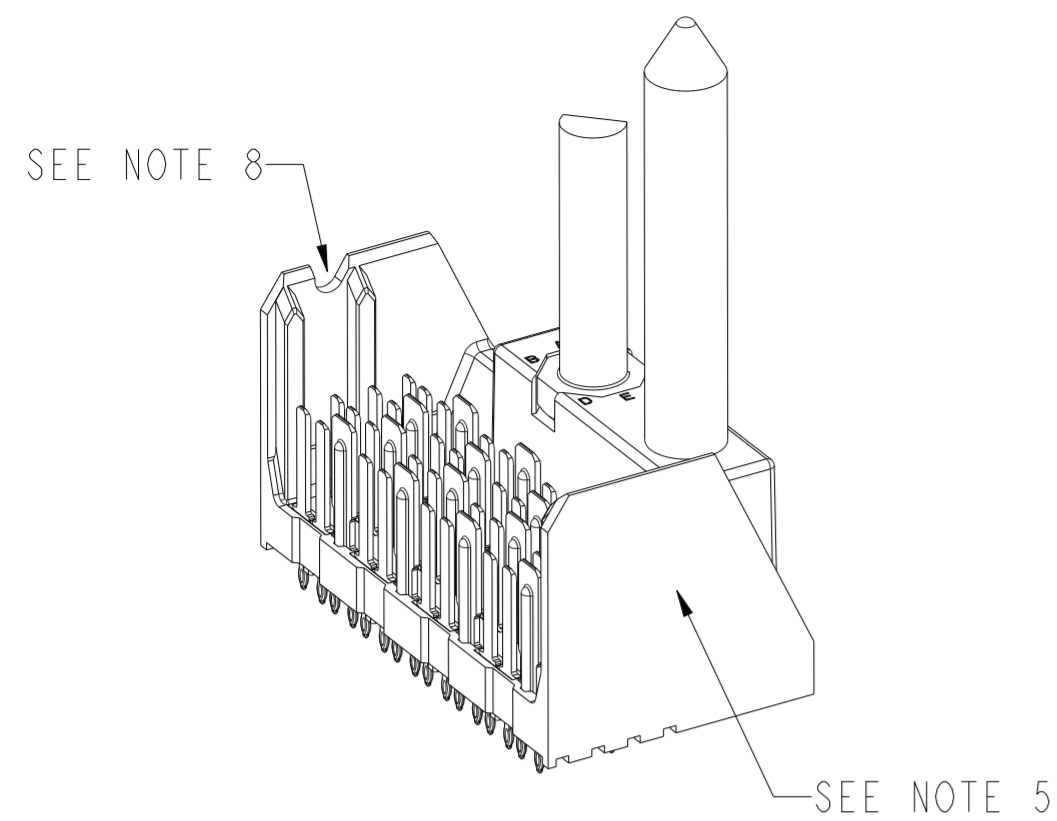

- 6.2 (4MM WIPE WIDE GROUNDS)
- 5.2 (3MM WIPE WIDE GROUNDS)
- 5.2 (3MM SMALL END GROUNDS)
- 5.2 (3MM WIPE SIGNALS)
- 4.2 (2MM WIPE SIGNALS)
- SEE P/N TREE

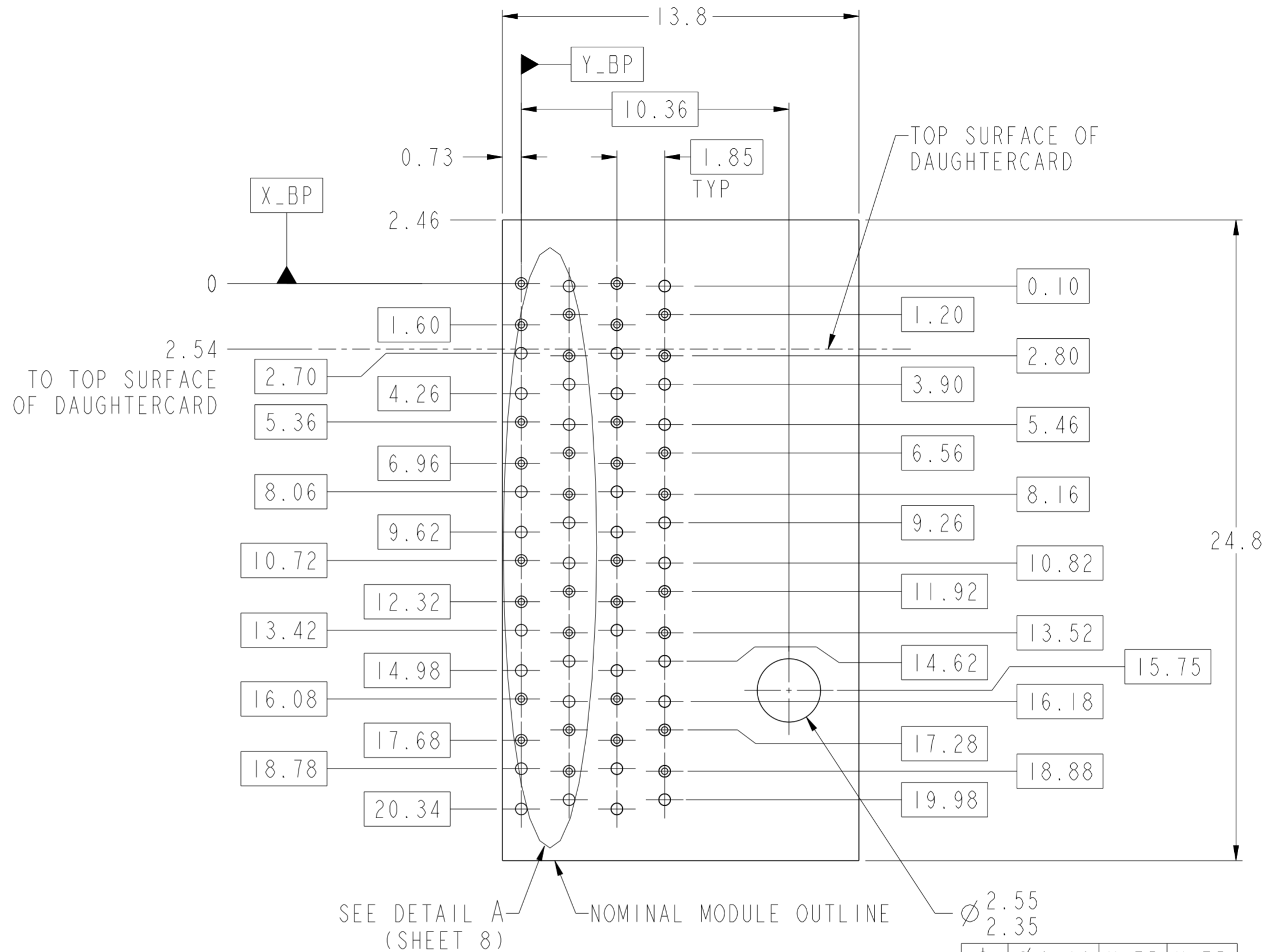
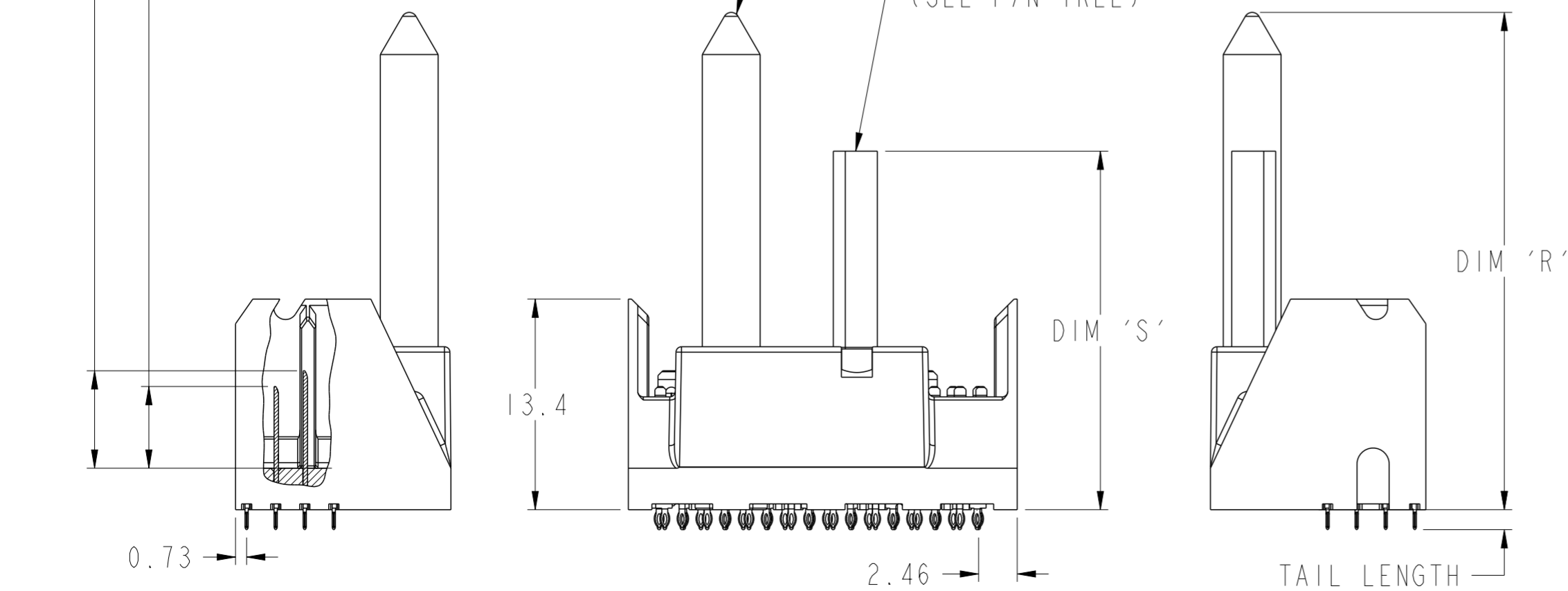

PCB HOLE PATTERN
COMPONENT SIDE
SCALE 6:1

$\varnothing 0.10$	X_BP	Y_BP
--------------------	------	------

SEE NOTE 11 & TABLE 1

ASSEMBLY BASE CONFIGURATION END DASH NO.	GUIDE PIN	POLARIZING KEY
	DIM 'R'	DIM 'S'
-X0X	31.6mm	22.8mm
-X4X	25.7mm	20.0mm

spec ref	SEE NOTES	dr	Jim Swain	2010/04/13	projection	MM	size	A2	scale	3:1	
tolerance std	TOLERANCES UNLESS OTHERWISE SPECIFIED	eng	Michael Song	2016/06/06		Product family	XCede	rel level	Released	ecn no	ELX-DG-24191-1
ASME Y14.5		chr	Heaven Cen	2016/06/08							rel level
surface	linear	0.X	±0.2	Amphenol FCI	MODULE ASSEMBLY	cat. no.	SEE P/N TREE	Product - Customer Drw	sheet 4 of 8	rev	G
		0.XX	±0.10								10091836
ASME Y14.5	angular	0.XXX	±0.050								
		0°	±°								

LEFT WALL MODULE

SEE NOTE 8

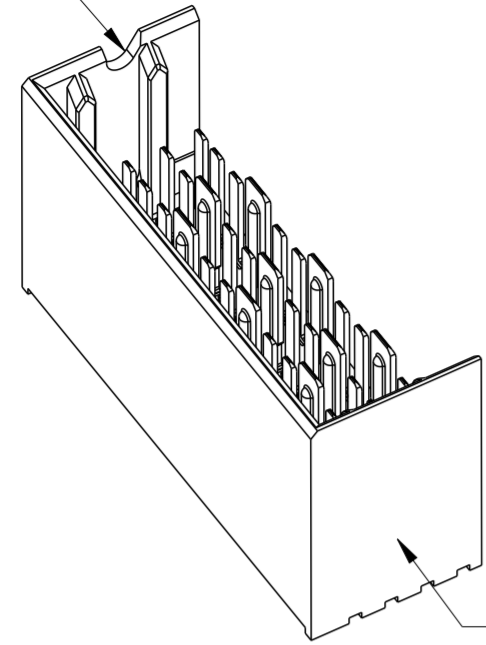

SEE NOTE 5

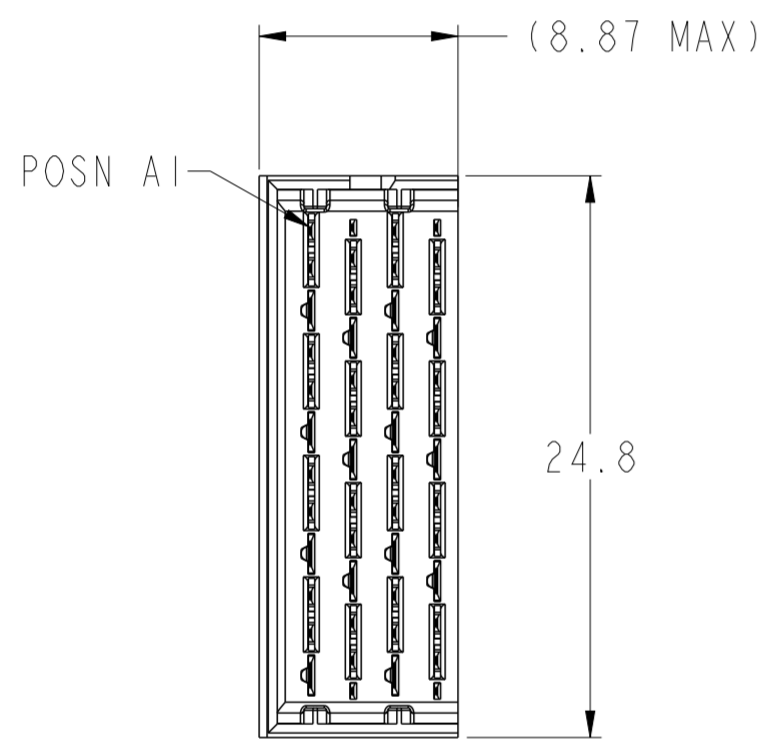
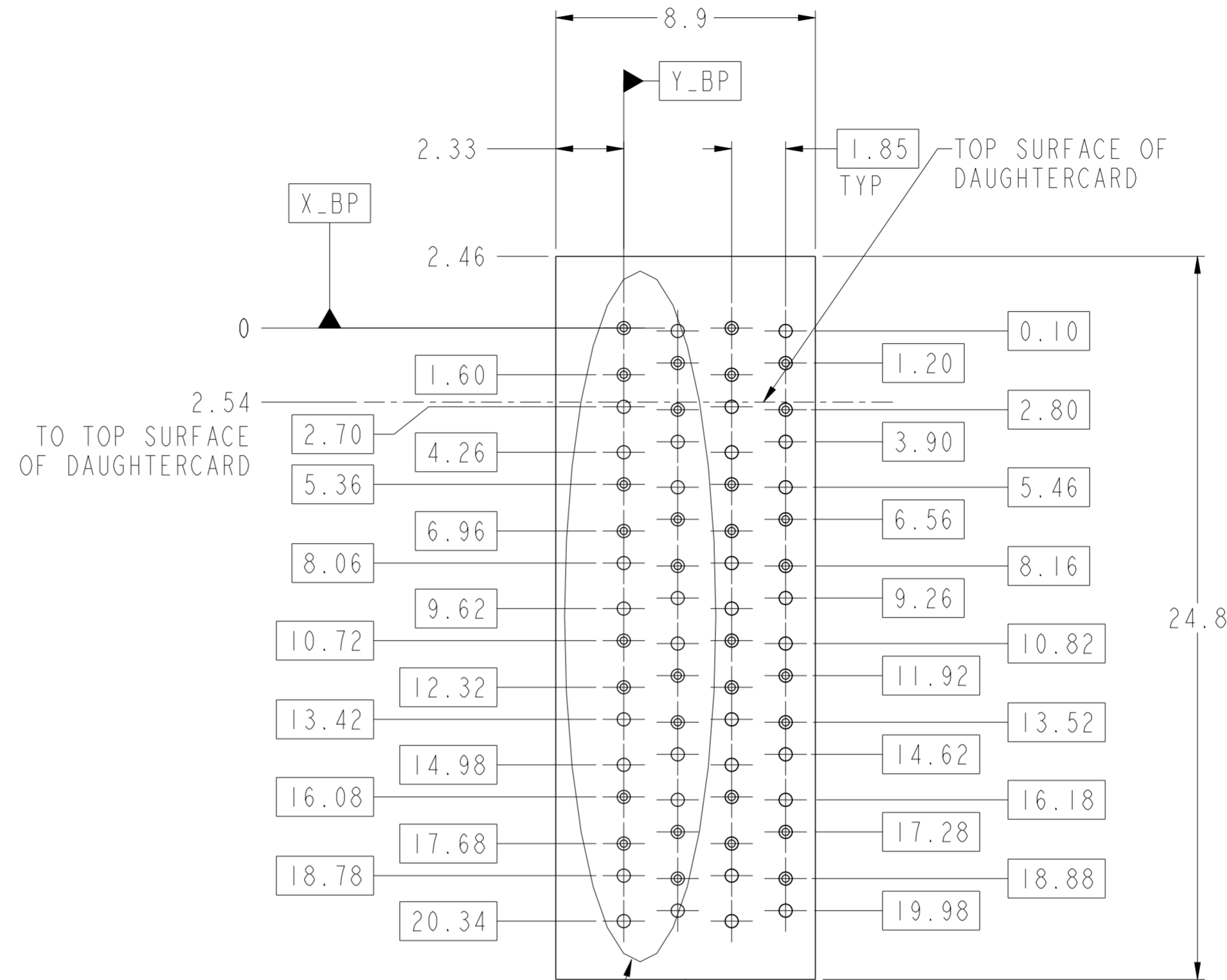

- 6.2 (4MM WIPE WIDE GROUNDS)
- 5.2 (3MM WIPE WIDE GROUNDS)
- 5.2 (3MM SMALL END GROUNDS)
- 5.2 (3MM WIPE SIGNALS)
- 4.2 (2MM WIPE SIGNALS)
- SEE P/N TREE

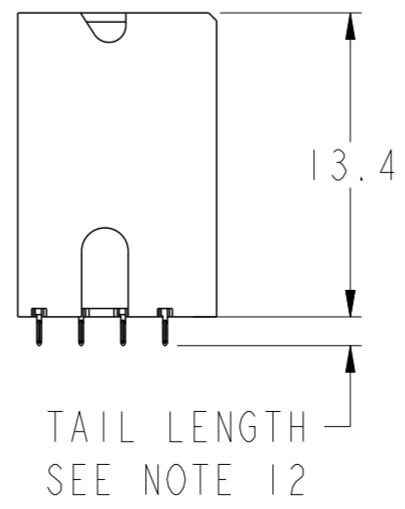
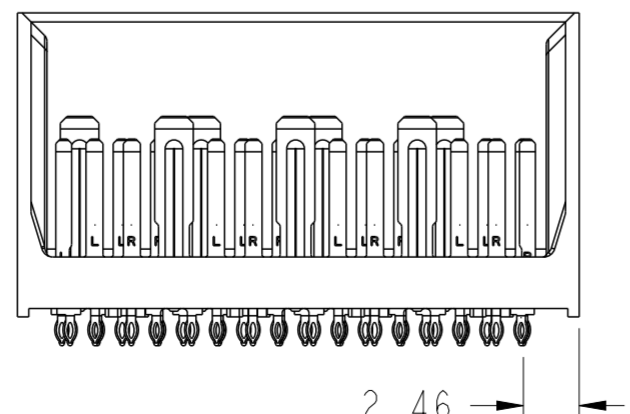
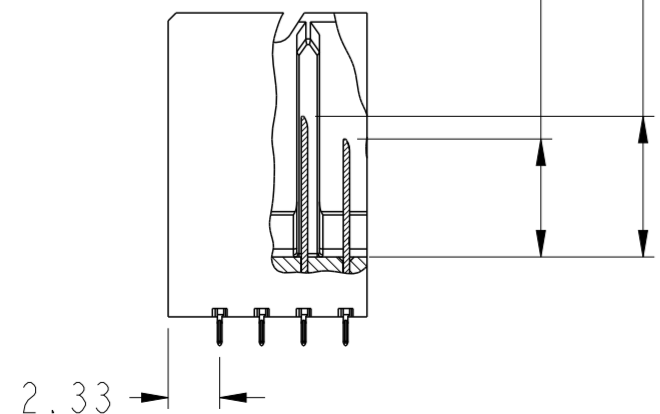

SEE DETAIL A (SHEET 8)

PCB HOLE PATTERN
COMPONENT SIDE
SCALE 6:1

spec ref	SEE NOTES	dr	Jim Swain	2010/04/13	projection	MM	size	A2	scale	3:1
tolerance std	ASME Y14.5	eng	Michael Song	2016/06/06			ecn no	ELX-DG-24191-1	rel level Released	
TOLERANCES UNLESS OTHERWISE SPECIFIED		chr	Heaven Cen	2016/06/08			product family	XCede		
		appr	Pai-Ming Zheng	2016/06/15			cat. no.	SEE P/N TREE		Product - Customer Drw
surface	ASME Y14.5	linear	0.X	±0.2	Amphenol FCI	MODULE ASSEMBLY VERTICAL HEADER, 4-COLUMN, 4-PAIR	dwg no	10091836	rev	G
			0.XX	±0.10						
		angular	0°	±°						

PDS: Rev :G

STATUS:Released

Printed: Jun 15, 2016

Amphenol FCI

© 2016 AFCI

RIGHT WALL MODULE

SEE NOTE 8

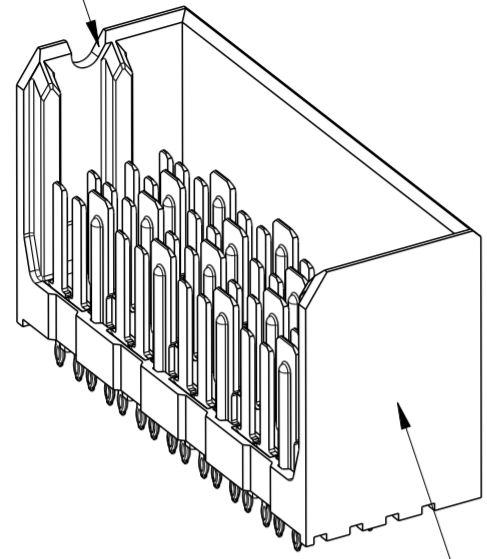

SEE NOTE 5

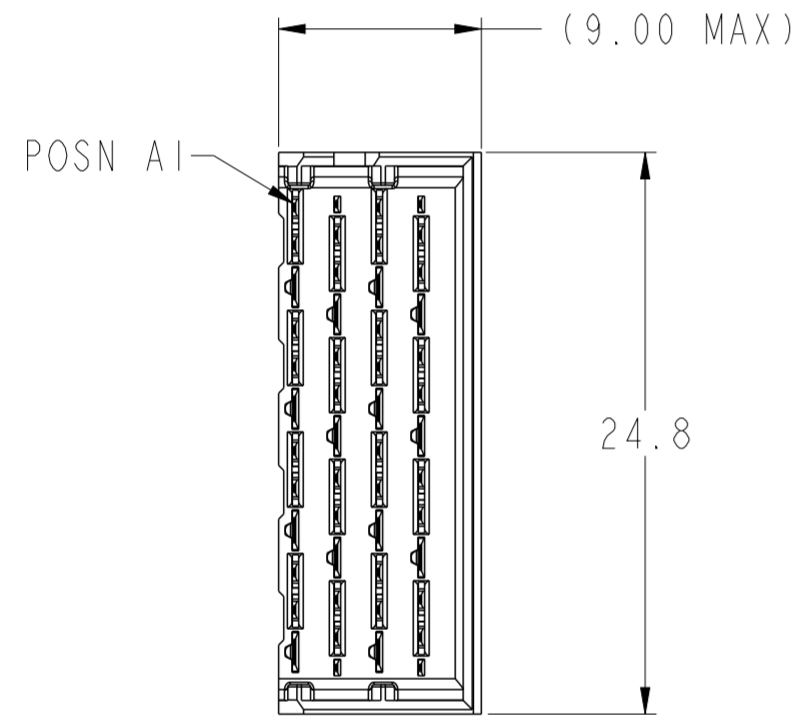

- 6.2 (4MM WIPE WIDE GROUNDS)
- 5.2 (3MM WIPE WIDE GROUNDS)
- 5.2 (3MM SMALL END GROUNDS)
- 5.2 (3MM WIPE SIGNALS)
- 4.2 (2MM WIPE SIGNALS)
- SEE P/N TREE

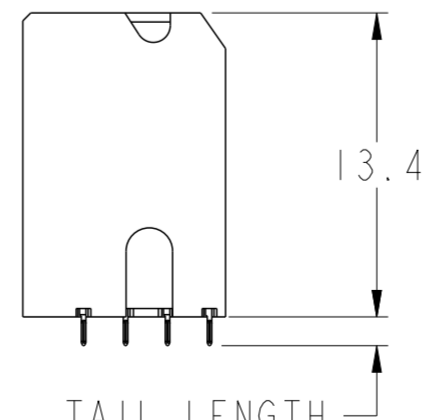
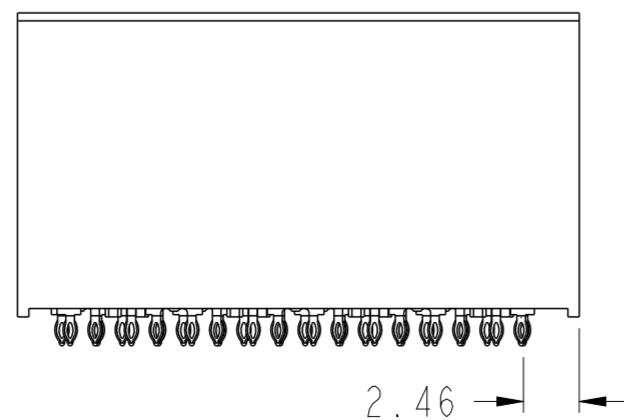
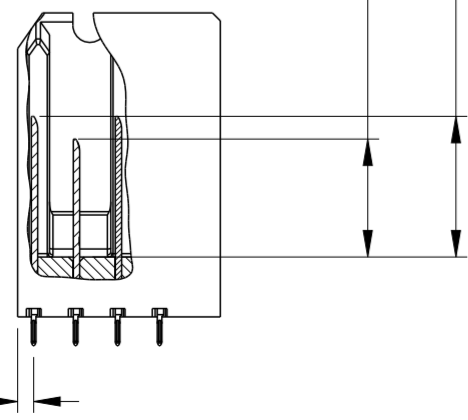

TAIL LENGTH
SEE NOTE 12

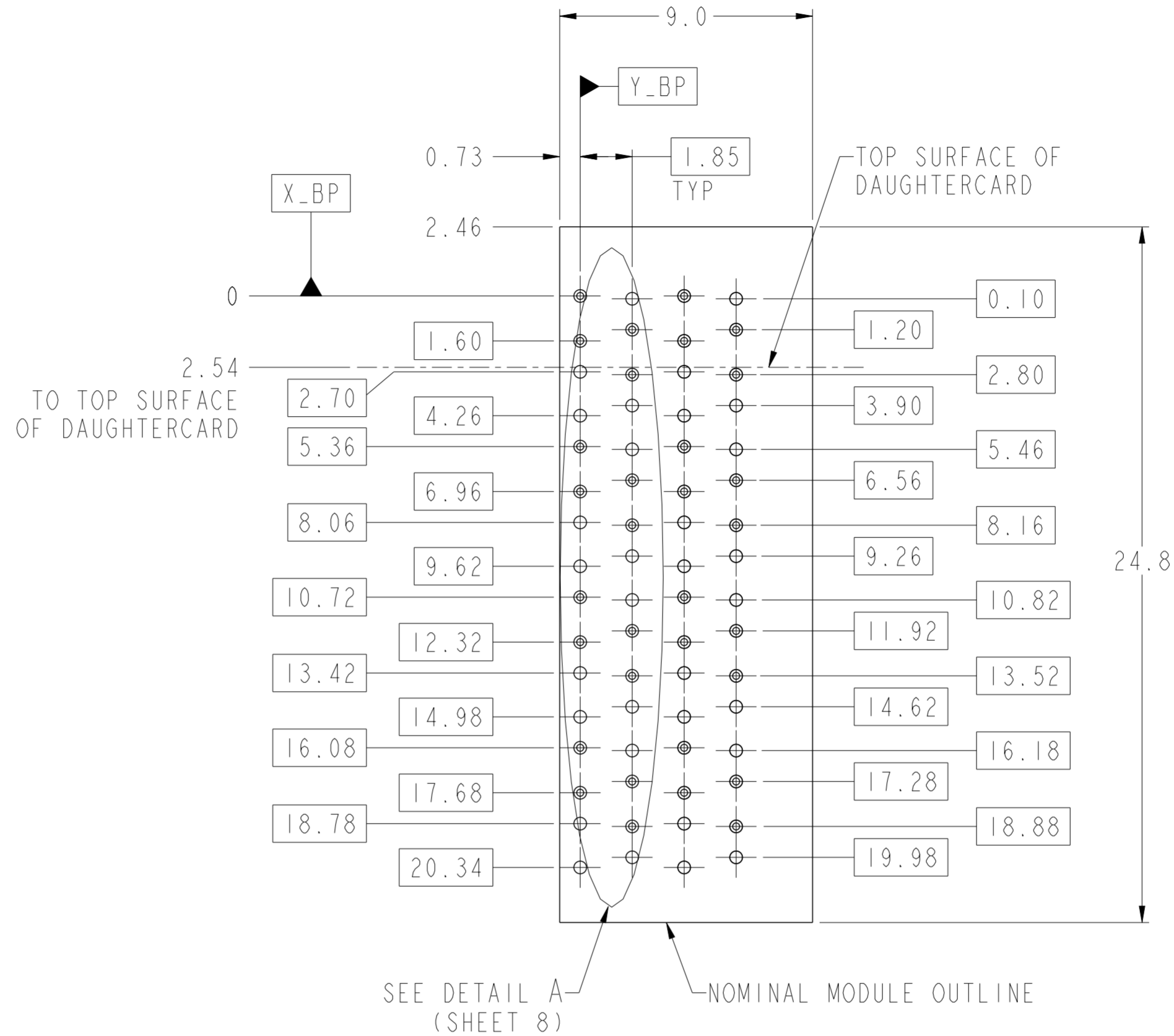

spec ref	SEE NOTES	dr	Jim Swain	2010/04/13	projection	MM	size	A2	scale	3:1
tolerance std	TOLERANCES UNLESS OTHERWISE SPECIFIED	eng	Michael Song	2016/06/06			ecn no	ELX-DG-24191-1	rel level	Released
ASME Y14.5		chr	Heaven Cen	2016/06/08						
		appr	Pai-Ming Zheng	2016/06/15						
surface	linear	0.X	±0.2	product family		XCede	rel level	10091836	rev	G
		0.XX	±0.10	SEE P/N TREE		Product - Customer Drw	sheet 6 of 8			
ASME Y14.5	angular	0.0XX	±0.050							
		0.XXX	±0.050							
		0°	±0°							

PDS: Rev :G

STATUS:Released

Printed: Jun 15, 2016

Amphenol FCI

© 2016 AFCI

4-WALL MODULE

SEE NOTE 8

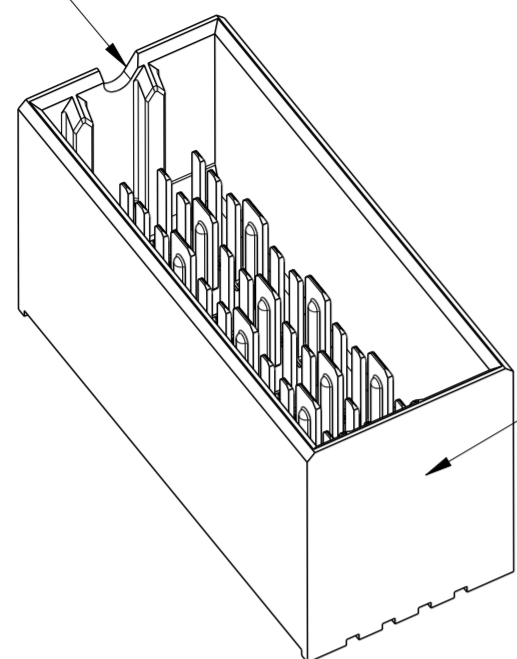

SEE NOTE 5

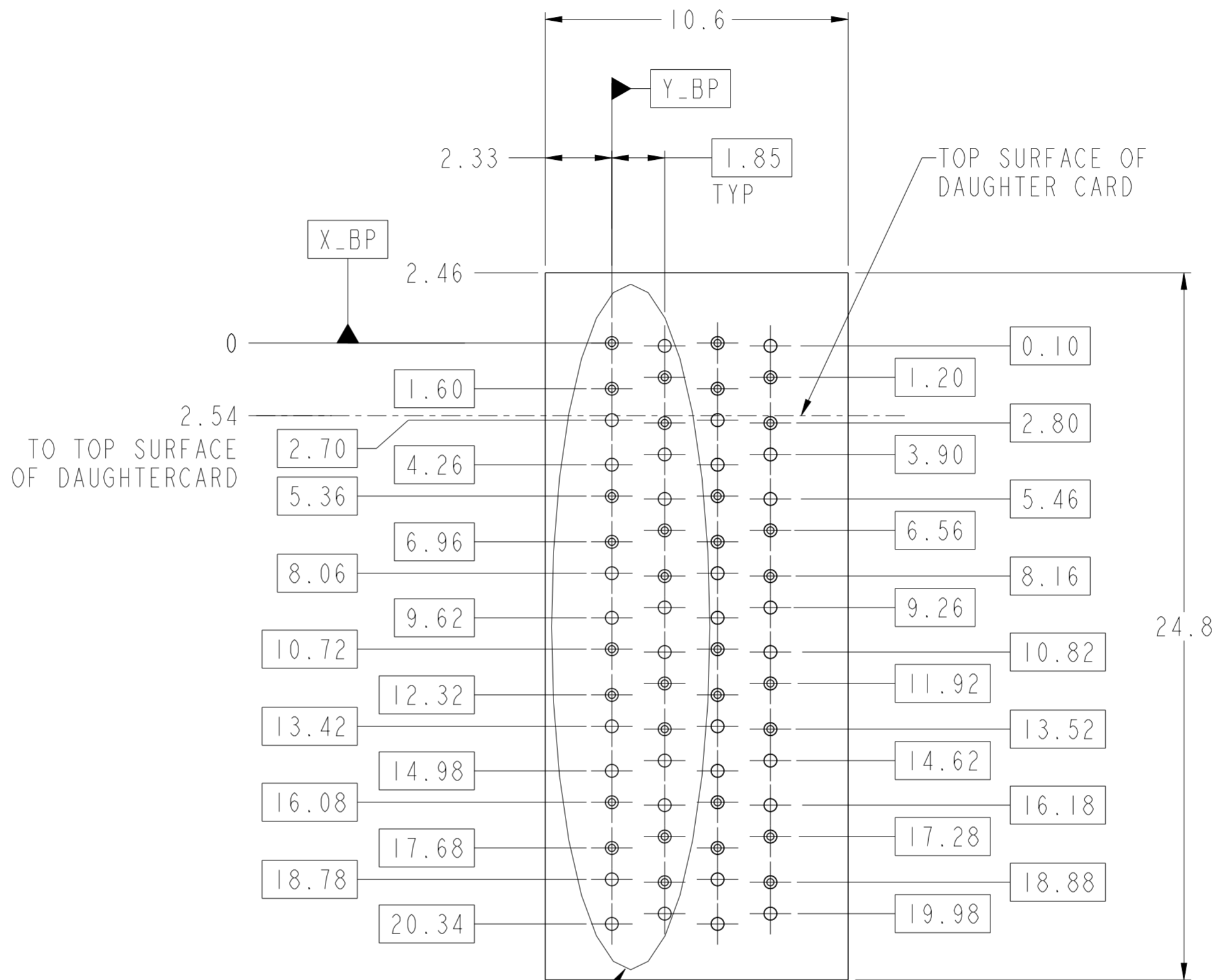

(10.50 MAX)

POSN A1

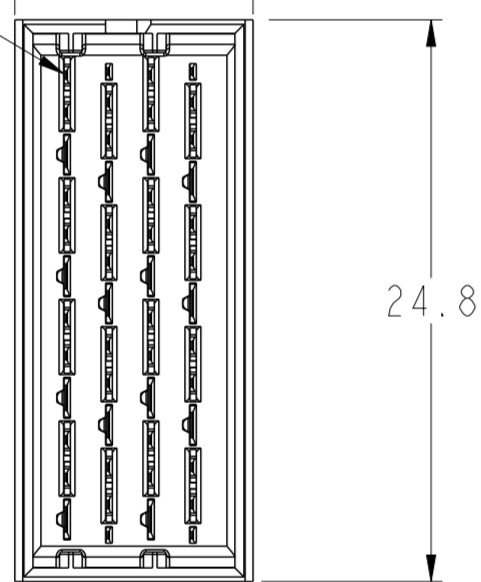

6.2 (4MM WIPE WIDE GROUNDS)

5.2 (3MM WIPE WIDE GROUNDS)

5.2 (3MM SMALL END GROUNDS)

5.2 (3MM WIPE SIGNALS)

4.2 (2MM WIPE SIGNALS)

SEE P/N TREE

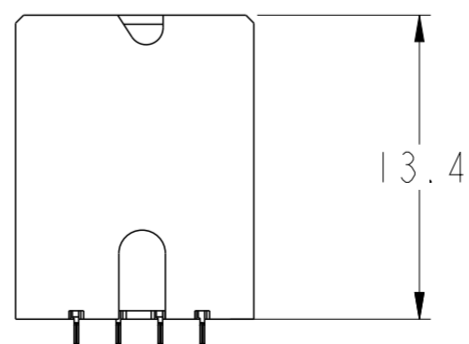
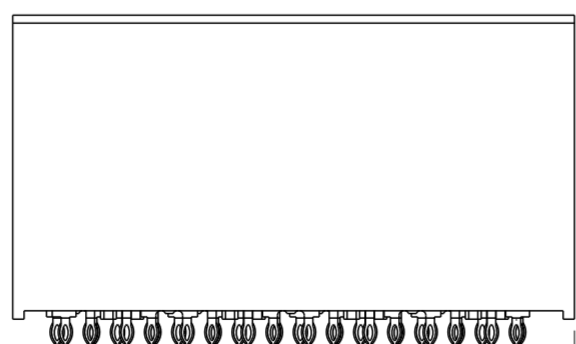
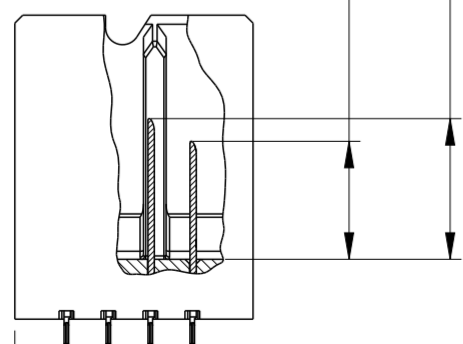

TAIL LENGTH
SEE NOTE 12

spec ref	SEE NOTES	dr	Jim Swain	2010/04/13	projection	MM	size	A2	scale	4:1
tolerance std	ASME Y14.5	eng	Michael Song	2016/06/06			ecn no	ELX-DG-24191-1		
TOLERANCES UNLESS OTHERWISE SPECIFIED		chr	Heaven Cen	2016/06/08				rel level	Released	
surface	linear	0.X	±0.2		MODULE ASSEMBLY VERTICAL HEADER, 4-COLUMN, 4-PAIR	cat. no.	Product - Customer Drw	sheet 7 of 8	rev G	
		0.XX	±0.10							
		0.XXX	±0.050							
ASME Y14.5	angular	0°	±°							

NOTES:

1. CONNECTOR MATERIALS
SHROUD: HIGH-TEMP THERMOPLASTIC, GRAY, UL94V-0
CONTACTS: HIGH PERFORMANCE COPPER ALLOY
2. CONTACT PLATING:

SEPARABLE INTERFACE: PERFORMANCE-BASED PLATING, QUALIFIED TO MEET THE REQUIREMENTS OF FCI PRODUCT SPECIFICATION GS-12-588, INCLUDING THE TELCORDIA GR-1217-CORE (NOVEMBER 1995) CENTRAL OFFICE (CO) OR UNCONTROLLED ENVIRONMENT (UE) TEST SEQUENCE AS NOTED IN P/N TREE.

PRESS-FIT TAILS: TIN OVER NICKEL (LF), OR TIN-LEAD ALLOY OVER NICKEL (NON-LF). SEE P/N TREE.
3. PRODUCT SPECIFICATION: GS-12-588
4. APPLICATION SPECIFICATION: GS-20-121
5. PRODUCT MARKING (PART NUMBER AND LOT CODE) ON THESE SURFACES.
6. HOUSING MUST WITHSTAND EXPOSURE TO 260°C PEAK TEMPERATURE FOR 40 SECONDS IN A CONVECTION, INFRA-RED, OR VAPOR-PHASE REFLOW OVEN.
7. PACKAGING MEETS GS-14-920 LEAD-FREE LABELING SPECIFICATION.
8. NOTCH INDICATES "ROW A" SIDE OF CONNECTOR.
9. SEE APPLICATION SPECIFICATION FOR ROUTING GUIDELINES, ADDITIONAL PTH GUIDELINES, MATED DIMENSIONS, GUIDE PN SELECTION, ETC.
10. SCREW IS OPTIONAL AND ENGAGES WITH BOTTOM OF GUIDE-PIN FROM BENEATH THE PCB FOR ADDITIONAL GUIDE-PIN SUPPORT.
11. OPTIONAL HOLE LOCATION FOR GROUNDED PIN OR ADDITIONAL GUIDE-PIN SUPPORT. SEE TABLE 1 ON SHEET 1 FOR ADDITIONAL DETAILS.
12. TAIL LENGTH=1.3mm FOR $\varnothing 0.55$ [0.0217"]COMPLIANT PIN DRILL
TAIL LENGTH=1.5mm FOR $\varnothing 0.45$ [0.0177"]COMPLIANT PIN DRILL

TABLE 3: PTH AND PAD SIZES WITH REFERENCE TO COMPLIANT PIN DRILL

COMPLIANT PIN DRILL	PTH	PAD
$\varnothing 0.55$ [0.0217"]	$\varnothing 0.45 \pm 0.05$	$\varnothing 0.85$
$\varnothing 0.45$ [0.0177"]	$\varnothing 0.36 \pm 0.05$	$\varnothing 0.75$

SEE TABLE 3 FOR PTH, DRILL & PAD SIZES

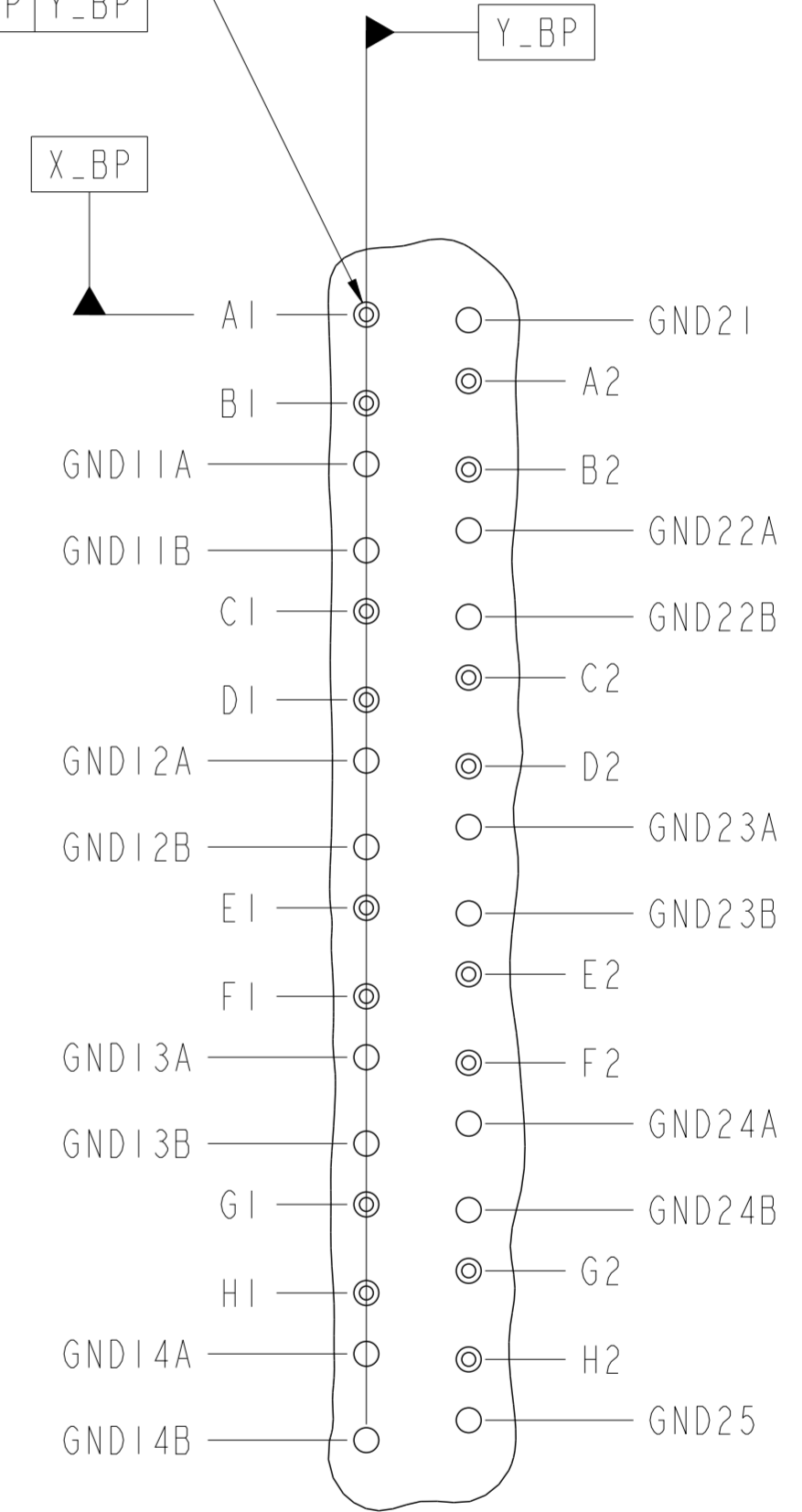

DETAIL A
SCALE 8:1

spec ref	SEE NOTES	dr	Jim Swain	2010/04/13	projection	MM	size	A2	scale	4:1
tolerance std	TOLERANCES UNLESS OTHERWISE SPECIFIED	eng	Michael Song	2016/06/06			ecn no	ELX-DG-24191-1	rel level	Released
ASME Y14.5		chr	Heaven Cen	2016/06/08						
		appr	Pai-Ming Zheng	2016/06/15						
surface	linear	0.X	±0.2	Amphenol FCI		MODULE ASSEMBLY VERTICAL HEADER, 4-COLUMN, 4-PAIR		cat. no.	Product - Customer Drw	sheet 8 of 8
		0.XX	±0.10							
ASME Y14.5	angular	0.XXX	±0.050							