



Chipsmall Limited consists of a professional team with an average of over 10 year of expertise in the distribution of electronic components. Based in Hongkong, we have already established firm and mutual-benefit business relationships with customers from,Europe,America and south Asia,supplying obsolete and hard-to-find components to meet their specific needs.

With the principle of “Quality Parts,Customers Priority,Honest Operation,and Considerate Service”,our business mainly focus on the distribution of electronic components. Line cards we deal with include Microchip,ALPS,ROHM,Xilinx,Pulse,ON,Everlight and Freescale. Main products comprise IC,Modules,Potentiometer,IC Socket,Relay,Connector.Our parts cover such applications as commercial,industrial, and automotives areas.

We are looking forward to setting up business relationship with you and hope to provide you with the best service and solution. Let us make a better world for our industry!



Contact us

Tel: +86-755-8981 8866 Fax: +86-755-8427 6832

Email & Skype: info@chipsmall.com Web: www.chipsmall.com

Address: A1208, Overseas Decoration Building, #122 Zhenhua RD., Futian, Shenzhen, China





SF1000

Serial Flash Expansion Card

User's Manual

019-0102 • 011217-C



SF1000 User's Manual

Part Number 019-0102 • 011217-C • Printed in U.S.A.

© 2001 Z-World, Inc. • All rights reserved.

Z-World reserves the right to make changes and improvements to its products without providing notice.

Notice to Users

Z-WORLD PRODUCTS ARE NOT AUTHORIZED FOR USE AS CRITICAL COMPONENTS IN LIFE-SUPPORT DEVICES OR SYSTEMS UNLESS A SPECIFIC WRITTEN AGREEMENT REGARDING SUCH INTENDED USE IS ENTERED INTO BETWEEN THE CUSTOMER AND Z-WORLD PRIOR TO USE. Life-support devices or systems are devices or systems intended for surgical implantation into the body or to sustain life, and whose failure to perform, when properly used in accordance with instructions for use provided in the labeling and user's manual, can be reasonably expected to result in significant injury.

No complex software or hardware system is perfect. Bugs are always present in a system of any size. In order to prevent danger to life or property, it is the responsibility of the system designer to incorporate redundant protective mechanisms appropriate to the risk involved.

All Z-World products are 100 percent functionally tested. Additional testing may include visual quality control inspections or mechanical defects analyzer inspections. Specifications are based on characterization of tested sample units rather than testing over temperature and voltage of each unit. Z-World may qualify components to operate within a range of parameters that is different from the manufacturer's recommended range. This strategy is believed to be more economical and effective. Additional testing or burn-in of an individual unit is available by special arrangement.

Trademarks

- Dynamic C[®] is a registered trademark of Z-World, Inc.
- PLCBus[™] and Rabbit 2000[™] are trademarks of Z-World, Inc.
- Z80/Z180 is a trademark of Zilog Inc.



Z-World, Inc.

2900 Spafford Street
Davis, California 95616-6800
USA

Telephone: (530) 757-3737
Facsimile: (530) 757-3792
Web Site: <http://www.zworld.com>
E-Mail: zworld@zworld.com



TABLE OF CONTENTS

Introduction	5
Getting Started	7
Headers	7
Pinout	8
Connections	9
Rabbit 2000 Boards	9
Z180 Boards	12
Software	15
Dynamic C	16
SF1000.LIB Library Functions	16
Programming Information	18
Rabbit 2000 Boards	18
BL2000	19
Z180 Boards	20
Appendix. Specifications	21
General Specifications	21
Mechanical Specifications	22
Schematics	25

INTRODUCTION

The SF1000 is a serial-interfaced flash memory card designed to work with Z-World's single-board computers. Single-board computers equipped with the Rabbit 2000 processor can use the SF1000 with either a synchronous serial peripheral interface (SPI) or an emulated SPI via parallel I/O ports. Zilog Z180-based single-board computers must use the emulated SPI method.

Two SF1000 models are presently offered, as shown in Table 1.

Table 1. SF1000 Models

Model	Flash Memory Size
SF1000	8MB
SF1010	4MB

Larger memories will be possible in the future when parts become available.

These serial flash cards are ideal for applications that require the temporary storage of large amounts of data. This data can be retrieved or downloaded to another system via the controlling single-board computer using TCP/IP or serial communication, or the card itself may be removed to facilitate transferring the data to another location.

GETTING STARTED

Headers

The SF1000 comes with a 10-pin, 2 mm, 5×2 header located at J1 as shown in Figure 1. Headers, either plugs or sockets, SMT or through-hole, may also be installed at J2 or J3. The pinouts for these positions are identical, and allow for a connecting cable to be hooked up in different ways. There is also a location at J4 for a 7-pin in-line header or socket with 0.1" spacing. Position 6 at J4 is not used, which allows this connection to be keyed.

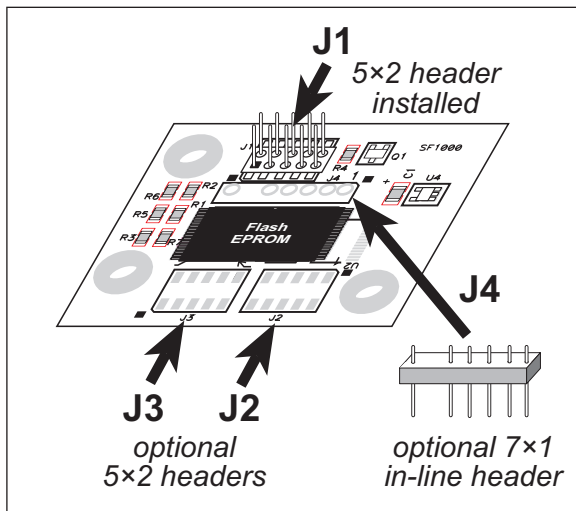

Figure 1. User Connection Points to SF1000

Pinout

Only six connections are required to interface the SF1000 with a Z-World single-board computer:

- +5 V
- Ground
- Chip Select input
- Serial Clock Input
- Serial Data Input
- Serial Data Output. This output is inverted because the serial flash is a 3 V part and the signal is converted to 5 V via an inverting transistor buffer.

Figure 2 shows the pinouts for the SF1000 header locations.

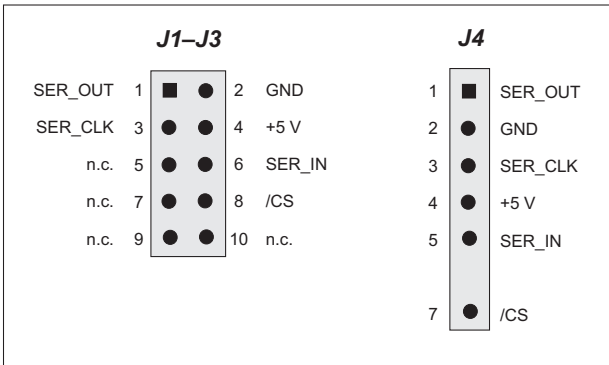

Figure 2. SF1000 Pinout

Connections

Rabbit 2000 Boards

Serial Port B on all the Rabbit-based boards (except the BL2000) is the recommended port to use to connect the SF1000 serial flash card. Table 2 lists the connections.

Table 2. SF1000 Connections to Rabbit-Based Board (except BL2000)

SF1000 Signal	Rabbit-Based Board	
+5 V	+5 V	
GND	GND	
SER_OUT	PC5 (RXB)	Serial Port B
SER_IN	PC4 (TXB)	
SER_CLK	PB0 (CLKB)	
/CS	user-selected output bit (default is PB7)	



Refer to the user’s manual for you Rabbit-based single-board computer for the locations of these connection pins.

While Serial Port B is the recommended port for connecting the SF1000 serial flash card, the programming port (Serial Port A), which is compatible with the header pinout on header J1 on the SF1000, or a parallel I/O port may also be used. A connector cable is available from Z-World if you wish to connect the SF1000 to the programming port (Serial Port A) on your Rabbit-based board.



Note that the programming port (Serial Port A) will not be available for application development and debugging if it is used to connect the SF1000 serial flash card.



Refer to the “Programming Information” section of the “Software” chapter for details of the software associated with your choice of connections.

A synchronous Serial Port B is not available on the BL2000, and so the following parallel-port connections are recommended instead.

Table 3. SF1000 Connections to BL2000

SF1000 Signal	BL2000 Board	
+5 V	+5 V	
GND	GND	
SER_OUT	IN10 (PB5)	
SER_IN	OUT3 (PA3)	Parallel Port A
SER_CLK	OUT2 (PA2)	
/CS	OUT1 (PA1)	

All three BL2000 outputs need to be pulled up to +5 V with a pull-up resistor of 1 kΩ to 2 kΩ. The following additional modifications need to be made.

- Remove R161 (removes GND from J9/J11 pin 12).
- Install R160 (adds VCC to J9/J11 pin 12).
- Remove C46, C47, and C48 (removes filter capacitors, which slow down the output signals).
- Remove C31 (removes filter capacitor, which slows down the input signals).

Figure 3 shows the locations of these components.

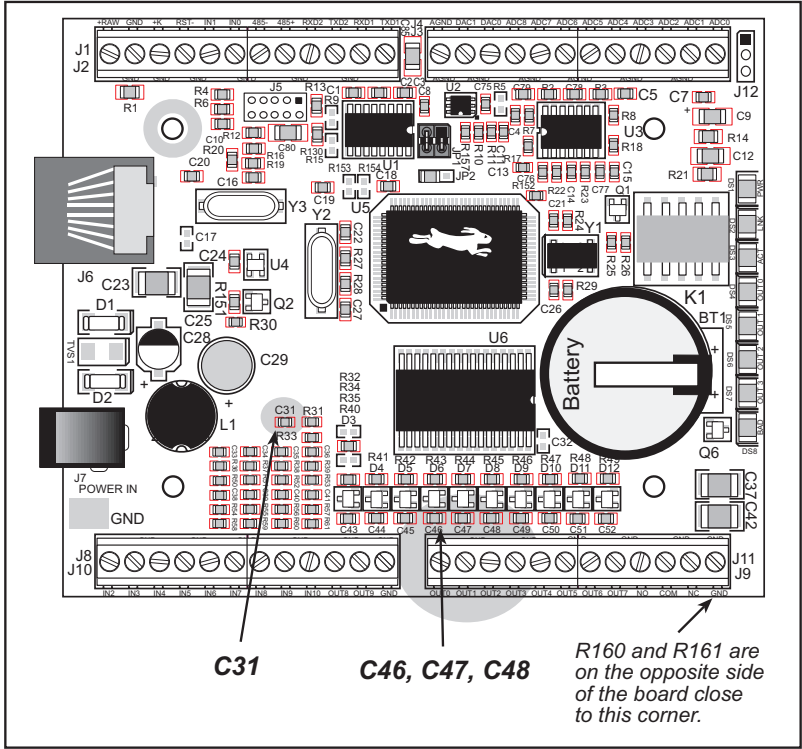

Figure 3. Locations of BL2000 Components to be Added or Removed

Z180 Boards

The following Z180-based boards are currently supported:

- BL1100
- BL1500
- BL1700
- LP3100
- PK2200

Figure 4 shows the connections to these boards. These connections may be modified as long as the library functions are also modified accordingly in the library specific to the single-board computer (e.g., **EZIOBL17.LIB**).

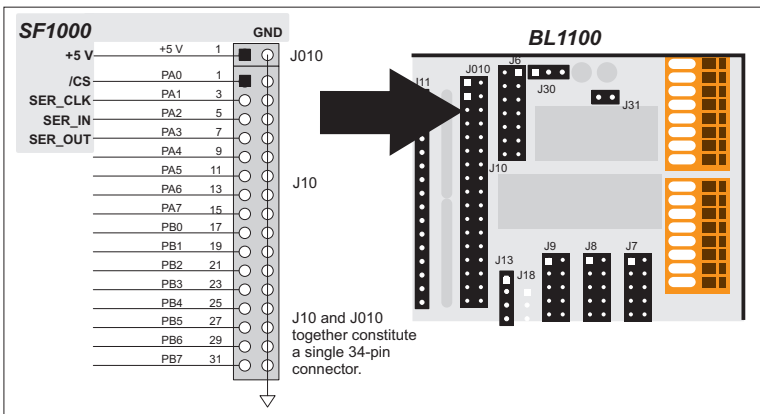

(a) BL1100 Connections

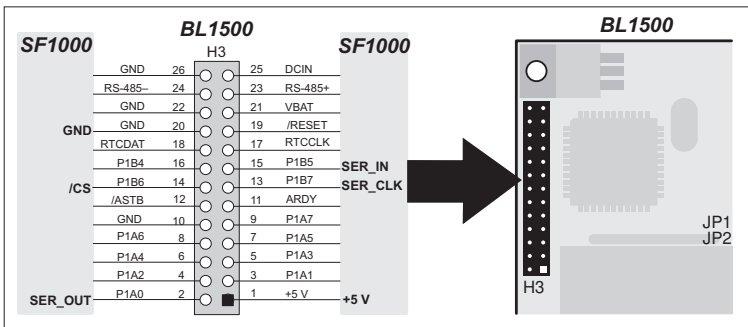

(b) BL1500 Connections

Figure 4. SF1000 Connections to Z180-Based Boards

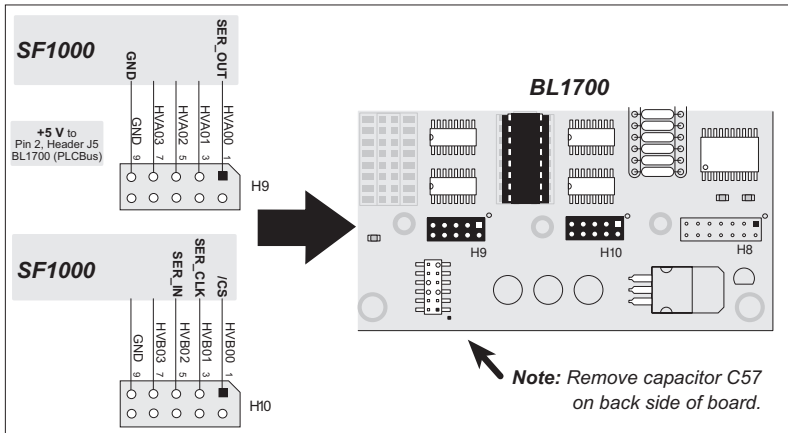

(c) BL1700 Connections



Note that a capacitor must be removed on the BL1700 as indicated in Figure 4(c) to keep the **SER_IN** signal from getting slowed down too much by the capacitor.

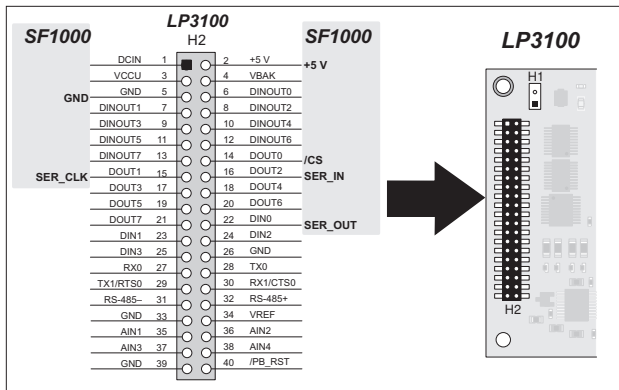

(d) LP3100 Connections

Figure 4. SF1000 Connections to Z180-Based Boards

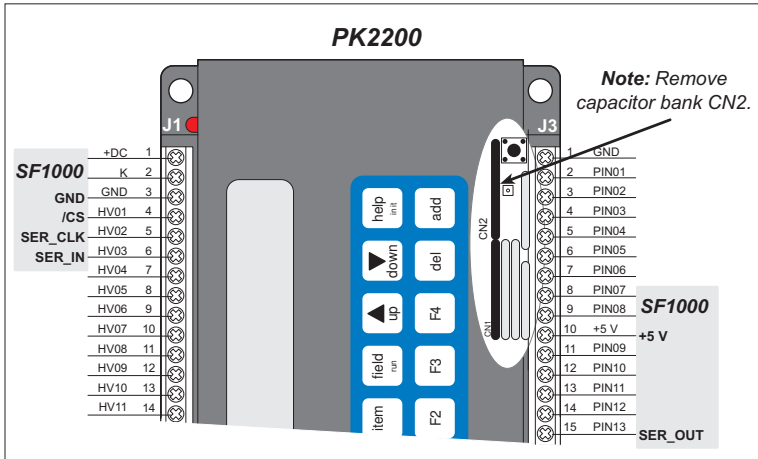

(e) PK220 Connections

Figure 4. SF1000 Connections to Z180-Based Boards



Note that a capacitor must be removed on the PK2200 as indicated in Figure 4(e) to keep the **SER_IN** signal from getting slowed down too much by the capacitor.

SOFTWARE

The SF1000 serial flash expansion card implements a flash memory chip with a single, large, linear address space. It is up to the user to maintain appropriate information within the program in order to store and retrieve data in the flash memory.

The flash memory chip consists of a series of “sectors.” The size of each sector is the same within a given chip, but can vary from one chip to another. A sector also contains extra bytes that are not made available to the user. Some of these bytes are used by the driver as follows:

- a fixed sync value, indicating that the sector has been written to at least once,
- a version number, and
- a long integer value for the number of times the sector has been written.

The user should keep in mind that a flash memory chip has a limited number of write cycles per sector, and that an entire sector must be written at a time. The chips used in the SF1000 serial flash cards are specified at 50,000 write cycles typical. The most efficient usage dictates that the user “block” all writing to the flash memory so that only full sectors are written.

More than one SF1000 serial flash card may be used in the control system built around the Z-World single-board computer. Users have to write their own **CS_enable/CS_disable** functions to control the chip select signals on the SF1000 serial flash cards. The only restriction is that all the SF1000 serial flash cards have the same size of flash memory chip, i.e., 4M or 8M.

Dynamic C

Z-World's Dynamic C integrated development software is used to add API functions from the **SF1000.LIB** library to your program. The **SF1000.LIB** library is available in Dynamic C Premier for Rabbit-based boards and in DC 32 for selected Z180-based boards.

SF1000.LIB Library Functions

The following API functions are available in the Dynamic C **SF1000.LIB** library. These functions are blocking functions, but do not disable interrupts. The functions are not re-entrant.

- **int SF1000Init (void);**

Minimum setup needed to verify correct flash operation.

PARAMETERS: None.

RETURN VALUES:

- 0 = success
- 1 = invalid density value read
- 2 = unknown response
- 3 = maybe no SF1000?

GLOBALS DEFINED:

```
int SF1000_Density_Value
int SF1000_Sector_size
int SF1000_Block_size
int SF1000_Nbr_of_Blocks
```

- **int SF1000Write (long FlashAddrDest, void* Data, int ByteCount);**

Write a block of data to the flash.

PARAMETERS:

- 1 = (**long**) address of destination
- 2 = (**void***) source RAM starting address
- 3 = (**int**) number of bytes to write

RETURN VALUES:

- 0 = success
- 1 = illegal byte count
- 2 = illegal flash address

- **int SF1000Read (long FlashAddrSource, void* Data, int ByteCount);**

Read a block of data from the flash.

PARAMETERS:

- 1 = (**long**) address of source
- 2 = (**void***) destination RAM starting address
- 3 = (**int**) number of bytes to write

RETURN VALUES:

- 0 = success
- 1 = illegal byte count
- 2 = illegal flash address

- **long SF1000CheckWrites (int Block);**

Read the number of times that a block has been written.

PARAMETER: (**int**) block number (0 relative)

RETURN VALUE: the number of times the block has been written.

Programming Information

Rabbit 2000 Boards

Define the following values *before* the `#use SF1000.LIB` statement.

1. Interface (default is `SF1000_SER_B`)

`SPI_SER_A` use Serial Port A
`SPI_SER_B` use Serial Port B
`SPI_PARALLEL` use a parallel I/O port

2. SPI bit rate (if using a serial port—default is 5)

`SPI_CLK_DIVISOR`

This is the divisor for the appropriate Timer A register.

3. I/O bit to be used for Chip Select (default is PB7)

`SF1000_CS_PORT`
`SF1000_CS_PORTSHADOW`
`SF1000_CS_BIT`

4. I/O bits for parallel interface

`SPI_TX_REG` register for clock and Tx data (default is PDDR)
`SPI_TXD_BIT` bit number for Tx data (default is bit 1)
`SPI_CLK_BIT` bit number for clock (default is bit 0)
`SPI_RX_REG` register for Rx data (default is PDDR)
`SPI_RXD_MASK` mask for Rx bit (default is 8, bit 3)

The default values will be used if `SPI_TX_REG` is not defined. If `SPI_TX_REG` is defined, then all the values must be defined.



The I/O port *must* be initialized for proper operation of the input and output!



If you are using the alternate Serial Port B I/O pins, you need to define `SERB_USEPORTD`.

BL2000

These are the required setup definitions when the BL2000 connections are made using Parallel Port A as described in this manual.

```
#define SPI_MODE_PARALLEL 1 // show using parallel I/O
#define SF1000_CS_PORT PADR
#define SF1000_CS_PORTSHADOW PADRShadow
#define SF1000_CS_BIT 1
#define SPI_TX_REG PADR
#define SPI_TXD_BIT 3
#define SPI_CLK_BIT 2
#define SPI_RX_REG PBDR
#define SPI_RXD_MASK 0x20
#define SPI_INVERT_CLOCK

// define the chip select macro

#define CS_ENABLE BitWrPortI ( SF1000_CS_PORT,
    &SF1000_CS_PORTSHADOW, 1, SF1000_CS_BIT );
#define CS_DISABLE BitWrPortI ( SF1000_CS_PORT,
    &SF1000_CS_PORTSHADOW, 0, SF1000_CS_BIT );
#define PROC_RABBIT
```

These are the initialization statements.

```
brdInit(); // initialize the I/O of the BL2000
SPIxor = 0xFF; // invert the received bits due to
                // inverter on SF1000
SPITXxor = 0xFF; // invert the transmitted bits
                // due to BL2000 output
```

Z180 Boards

The following Z180-based boards are currently supported.

- BL1100
- BL1500
- BL1700
- LP3100
- PK2200

Figure 3 in the “Getting Started” chapter shows the connections to these boards. These connections may be modified as long as the library functions are also modified accordingly in the library specific to the single-board computer (e.g., **EZIOBL17.LIB**).

APPENDIX. SPECIFICATIONS

General Specifications

Table A-1 lists the electrical, mechanical, and environmental specifications for an SF1000 serial flash card.

Table A-1. SF1000 General Specifications

Parameter	Specification	
Board Size	1.51" × 1.75" × 0.25" (38.4 mm × 44.5 mm × 6.4 mm)	
Operating Temperature	-40°C to 70°C	
Humidity	5% to 95%, noncondensing	
Input Voltage and Current	4.75 V to 5.25 V DC, 60 mA maximum	
Flash Memory	8M (SF1000) 4M (SF1010)	
Serial Data Rate*	BL1700 @ 18.4 MHz (SF1010)	Read 70 ms/block Write 88 ms/block
Block size SF1000: 1024 bytes SF1010: 512 bytes	RCM2000 @ 25.8 MHz (SF1000)	Read 14.0 ms/block Write 27.5 ms/block
	RCM2000 @ 25.8 MHz (SF1010)	Read 7.3 ms/block Write 23.5 ms/block

* The BL1700 measurements were made using a "bit-banged" parallel I/O port to simulate an SPI; the RCM2000 measurements were made using a synchronous serial interface (SPI).

Mechanical Specifications

Figure A-1 shows the mechanical dimensions of an SF1000.

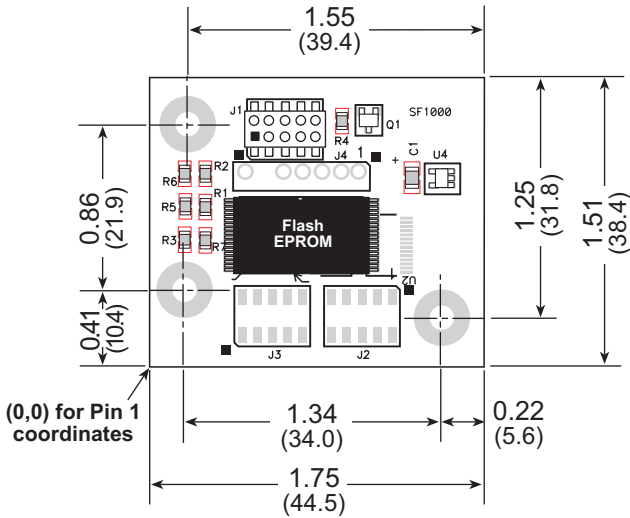

Figure A-1. SF1000 Dimensions

Table A-2 lists the pin 1 locations.

Table A-2. SF1000 Pin 1 Locations (in inches)

Header		Location
J1	installed	0.551, 1.202
J2	not installed	1.267, 0.306
J3	not installed	0.485, 0.230
J4	not installed	1.102, 1.021

Figure A-2 shows the footprint of another board that the SF1000 would be plugged into. These values are relative to the header connectors.

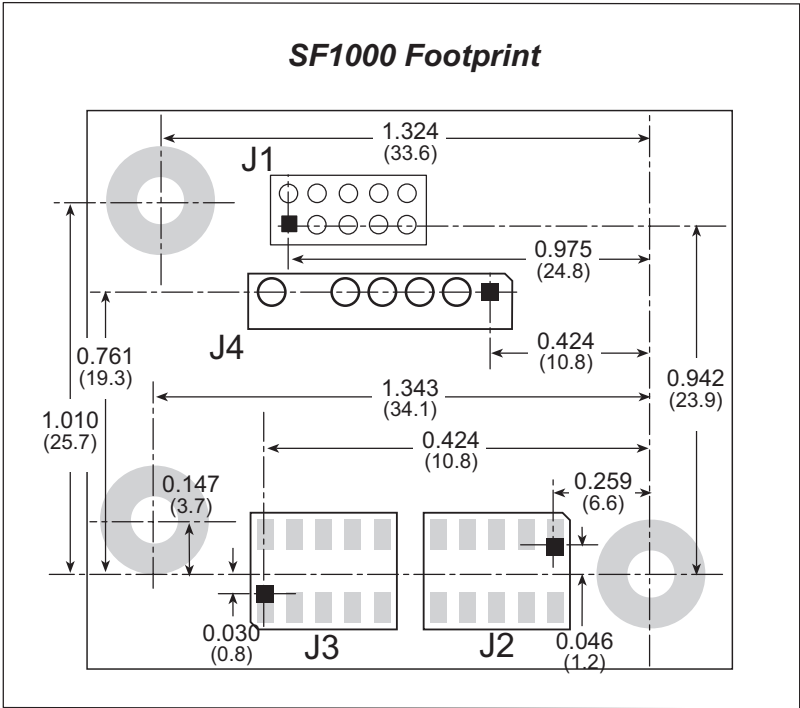

Figure A-2. User Board Footprint for SF1000



SSCHEMATICS