



Chipsmall Limited consists of a professional team with an average of over 10 year of expertise in the distribution of electronic components. Based in Hongkong, we have already established firm and mutual-benefit business relationships with customers from,Europe,America and south Asia,supplying obsolete and hard-to-find components to meet their specific needs.

With the principle of “Quality Parts,Customers Priority,Honest Operation,and Considerate Service”,our business mainly focus on the distribution of electronic components. Line cards we deal with include Microchip,ALPS,ROHM,Xilinx,Pulse,ON,Everlight and Freescale. Main products comprise IC,Modules,Potentiometer,IC Socket,Relay,Connector.Our parts cover such applications as commercial,industrial, and automotives areas.

We are looking forward to setting up business relationship with you and hope to provide you with the best service and solution. Let us make a better world for our industry!



Contact us

Tel: +86-755-8981 8866 Fax: +86-755-8427 6832

Email & Skype: info@chipsmall.com Web: www.chipsmall.com

Address: A1208, Overseas Decoration Building, #122 Zhenhua RD., Futian, Shenzhen, China





All rights strictly reserved. Reproduction or issue to third parties in any form whatever is not permitted without written authority from the proprietor. Property of Fci. Copyright FCI.

Tous droits strictement reserves. Reproduction ou communication a des tiers interdite sous quelque forme que ce soit sans autorisation ecrite du proprietaire. Propriete de c FCI. Droits de reproduction FCI.

PART NUMBER
10103332-AXPLF

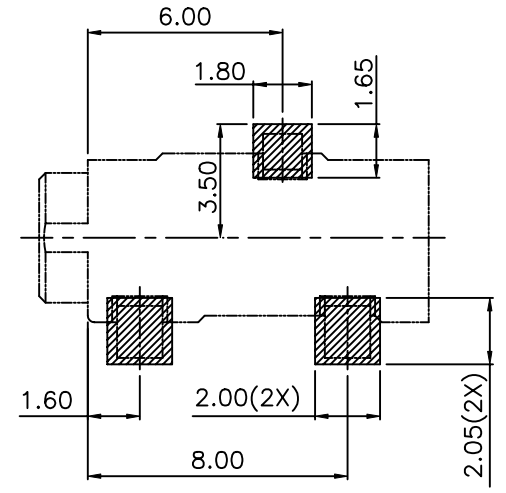
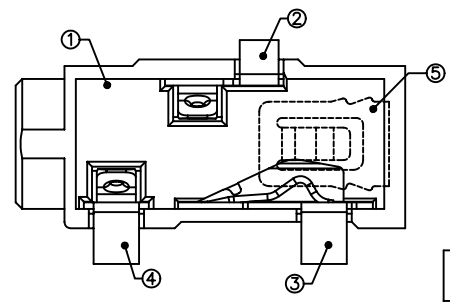
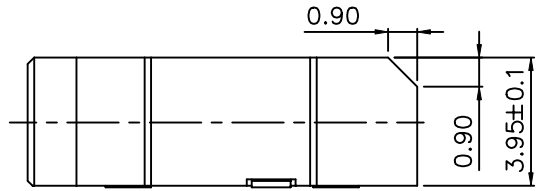
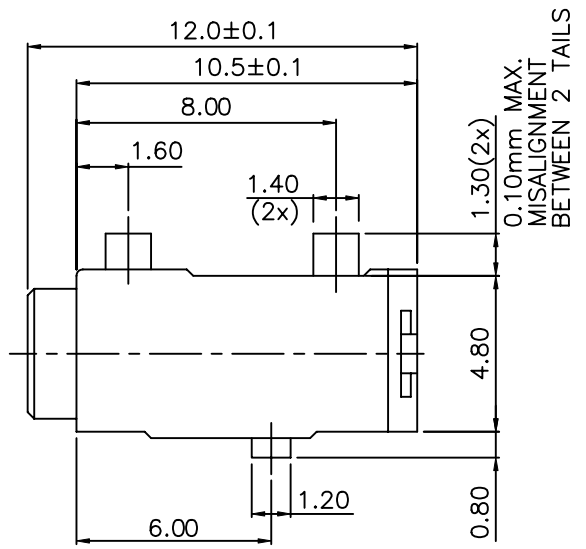
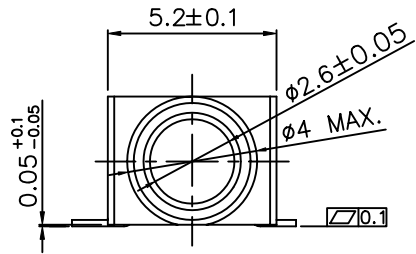

RECOMMENDED PCB LAYOUT
GENERAL TOLERANCE ±0.05mm(BOTTOM VIEW)

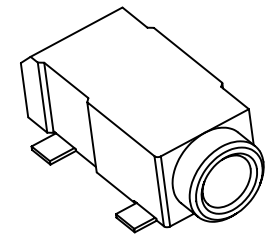

mat'l. code				tolerances unless otherwise specified			CUSTOMER COPY		FCI		www.fciconnect.com	
ltr	ecn no	dr	date	linear	.X ±0.30		projection	title				
A	T10-0044	WL	03/09/10		.XX ±0.20			Ø2.5 PHONE JACK				
B	T10-0087	WL	06/29/10		.XXX ±0.10			product family				
C	T10-0133	WL	08/12/10	angles	±2°		MM		size		code	
				dr	WENDY CHEN	07/30/09	scale		A4		TWN	
				enr	WENDY CHEN	07/30/09			10103332		sheet	
				chr	GARY HSIEH	07/30/09					1 of 2	
				appd	JOSEPH HSIA	07/30/09						
sheet	revision	C	C									
index	sheet	1	2									

ACAD

PDM: Rev:C

STATUS: Released 2010 Aug 17, 2010



NOTES :

1. MATERIALS :
 - a. ITEM 1: HOUSING : THERMOPLASTIC UL94 V-0, COLOR; BLACK.
 - b. ITEM 2,3,4 : CONTACT : COPPER ALLOY.
 - c. ITEM 5 : SPRING : STAINLESS STEEL.
2. PLATING :
CONTACT AND SOLDER AREA: SELECTIVE GOLD PLATED OVERALL,
AND 50u" MIN. NICKEL UNDER PLATED.
3. PRODUCT SPECIFICATION: GS-12-637.
4. PACKING SPECIFICATION: GS-14-1442.
5. THIS PRODUCT MEETS THE EUROPEAN UNION DIRECTIVE AS DESCRIBED IN GS-22-008.
6. THE HOUSING WILL WITHSTAND EXPOSURE TO 260°C PEAK TEMPERATURE FOR 10 SECONDS IN A CONVECTION, IR OR VAPER PHASE REFLOW OVEN.
7. PART NUMBER DESCRIPTION:

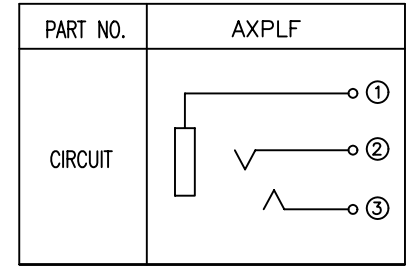
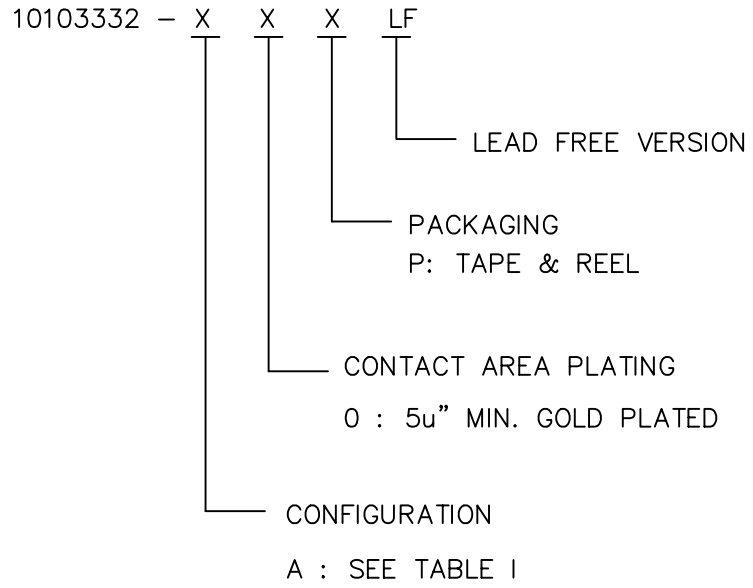

TABLE I

mat'l. code				tolerances unless otherwise specified		CUSTOMER COPY		FCI		www.fciconnect.com		
ltr	ecn no	dr	date	linear	.X ±0.30		projection	title				
C					.XX ±0.20				ø2.5 PHONE JACK			
					.XXX ±0.10				MM	product family		code
				angles	±2"		scale	size		sheet		
				dr	WENDY CHEN	07/30/09		A4	10103332		2 of	
				enr	WENDY CHEN	07/30/09			dwg no		TWN	
				chr	GARY HSIEH	07/30/09						
				appd	JOSEPH HSIA	07/30/09						
sheet index	revision sheet											