



Chipsmall Limited consists of a professional team with an average of over 10 year of expertise in the distribution of electronic components. Based in Hongkong, we have already established firm and mutual-benefit business relationships with customers from,Europe,America and south Asia,supplying obsolete and hard-to-find components to meet their specific needs.

With the principle of “Quality Parts,Customers Priority,Honest Operation,and Considerate Service”,our business mainly focus on the distribution of electronic components. Line cards we deal with include Microchip,ALPS,ROHM,Xilinx,Pulse,ON,Everlight and Freescale. Main products comprise IC,Modules,Potentiometer,IC Socket,Relay,Connector.Our parts cover such applications as commercial,industrial, and automotives areas.

We are looking forward to setting up business relationship with you and hope to provide you with the best service and solution. Let us make a better world for our industry!



## Contact us

Tel: +86-755-8981 8866 Fax: +86-755-8427 6832

Email & Skype: info@chipsmall.com Web: www.chipsmall.com

Address: A1208, Overseas Decoration Building, #122 Zhenhua RD., Futian, Shenzhen, China



PRODUCT NUMBER	PLATING OPT.	HSG&FRAME COLOR
10112633-101	OPTION 1	BLACK
10112633-101LF	OPTION 2	BLACK
10112633-121	OPTION 1	NATURAL
10112633-121LF	OPTION 2	NATURAL

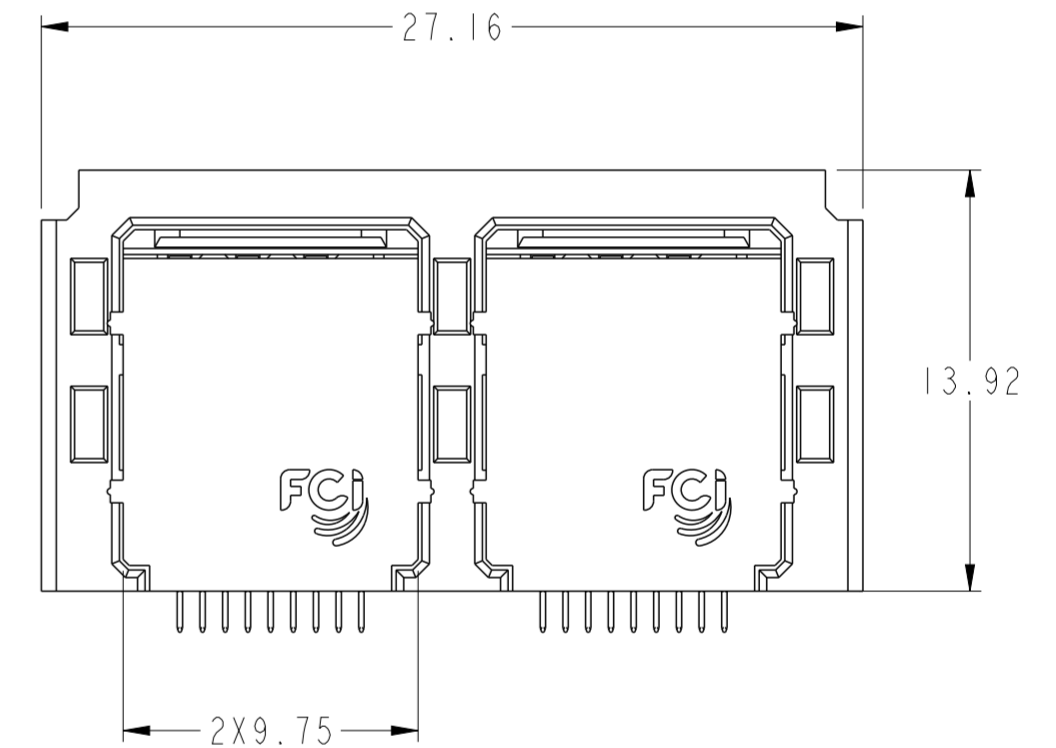
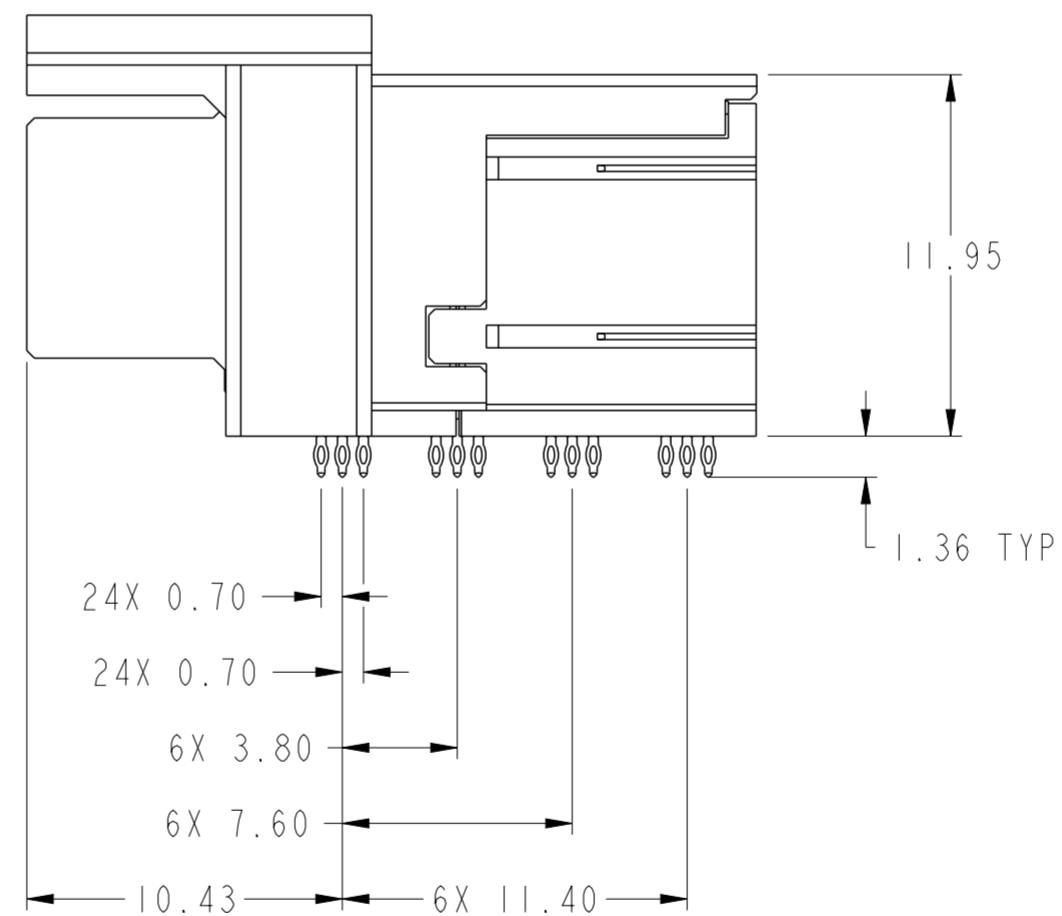
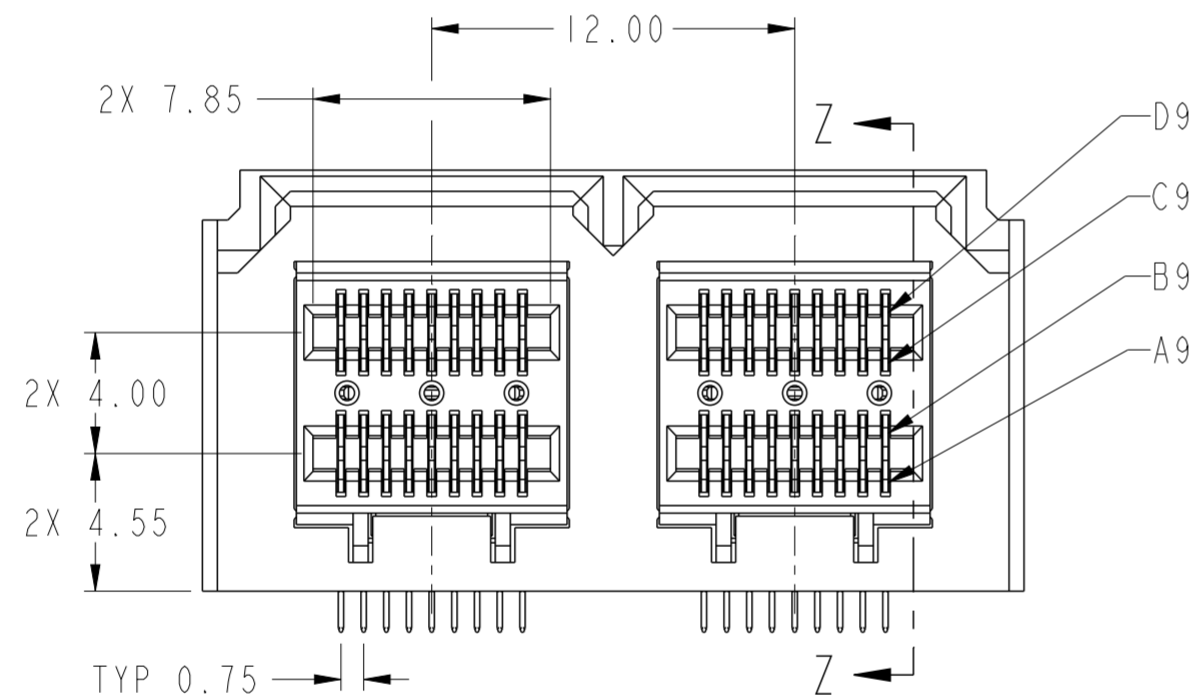
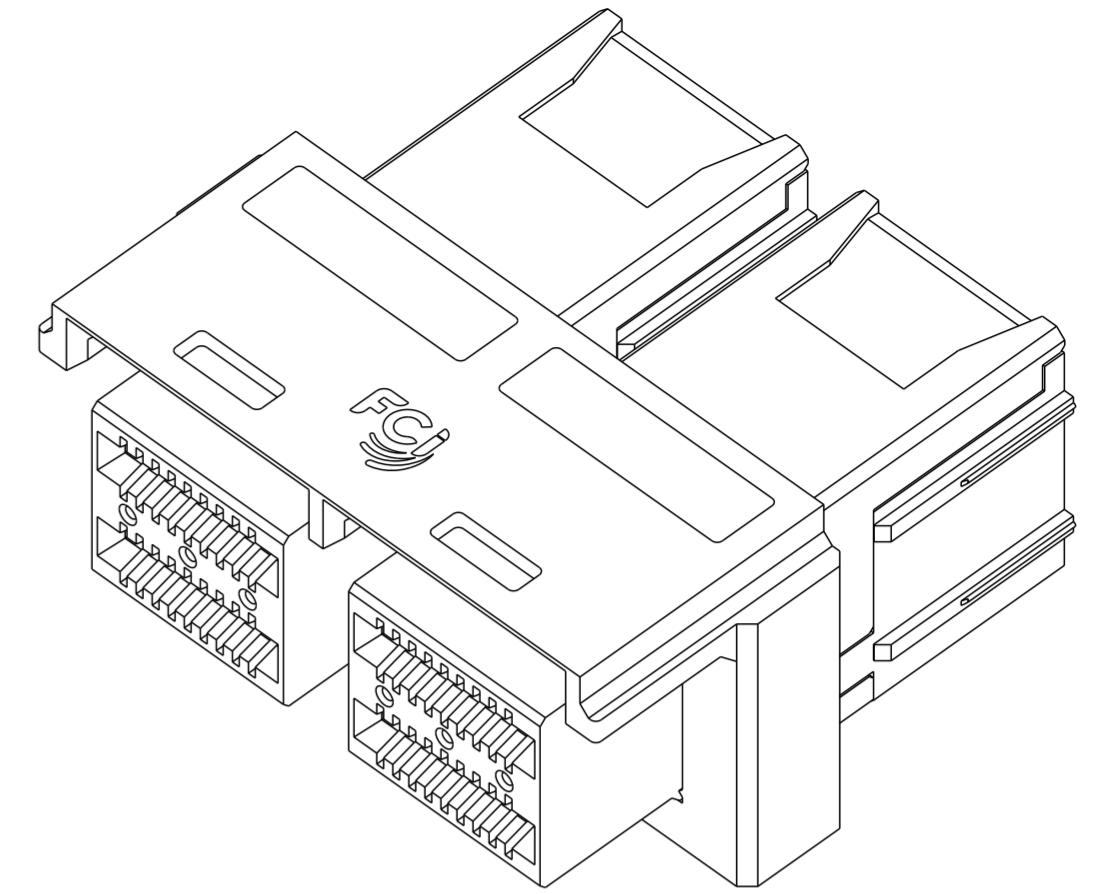
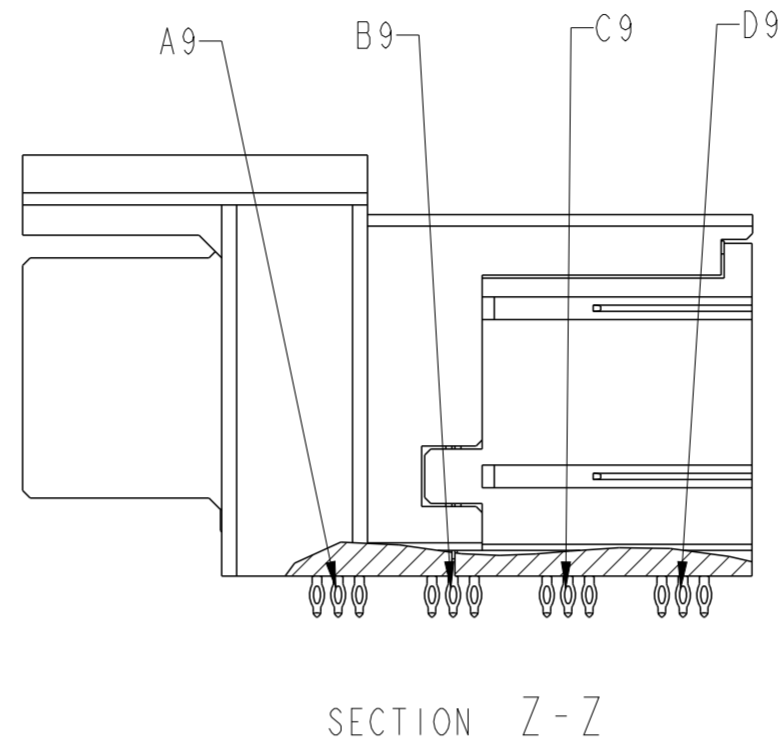
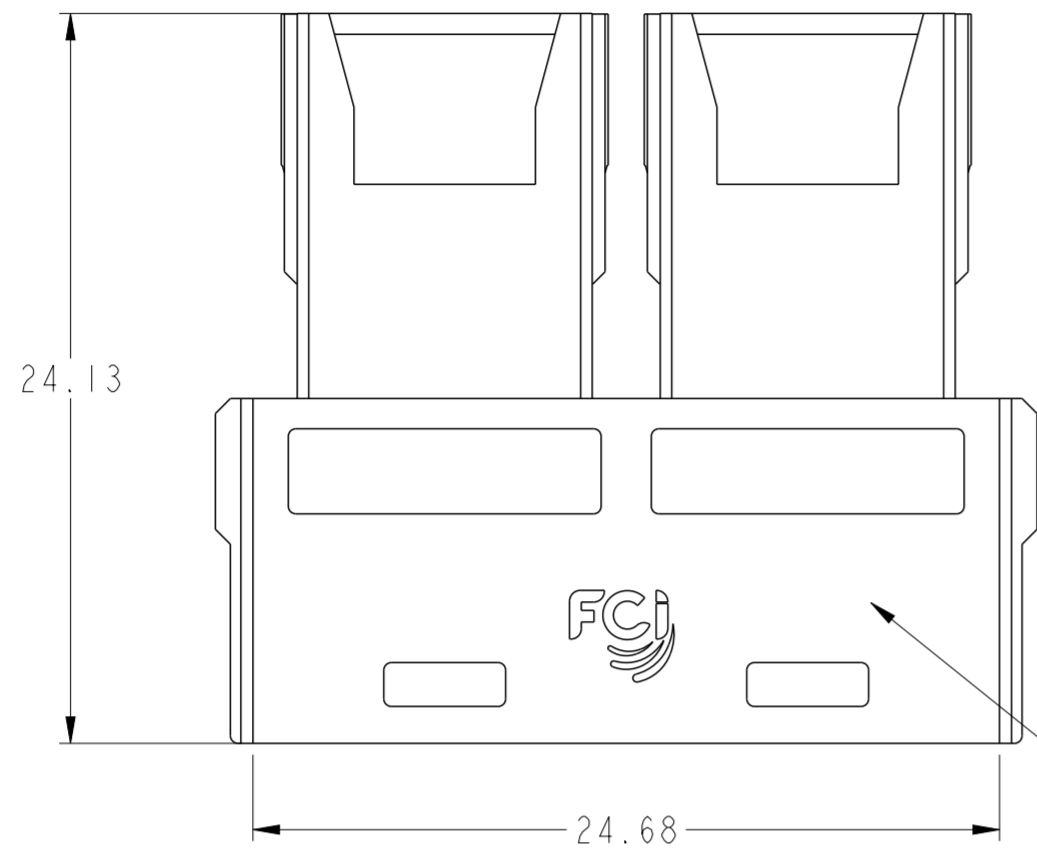

NOTES:

- MATERIALS:  
CONNECTOR HOUSING: HIGH TEMPERATURE THERMOPLASTIC, GLASS FILLED, UL 94V-0  
TERMINALS: COPPER ALLOY
- FINISHES:  
CONTACT AREA: 0.76µm GOLD OVER 2.54µm MIN NICKEL  
TAIL AREA:  
OPTION 1: 0.76µm - 1.52µm TIN/LEAD (90/10) OVER 2.54µm MIN NICKEL.  
OPTION 2: 0.76µm - 1.52µm TIN (LEAD FREE) OVER 2.54µm MIN NICKEL.
- PRODUCT SPECIFICATION: GS-12-650.  
APPLICATION SPECIFICATION: GS-20-0356  
PACKAGING SPECIFICATION: GS-14-1490
- RECOMMENDED MOUNTING HARDWARE:  
OPTION 1: M2 X 0.91mm SELF-THREADING SCREW  
OPTION 2: M2 X 0.80mm SELF-THREADING SCREW  
OPTION 3: M2 X 0.40mm SELF-THREADING SCREW  
RECOMMENDED MOUNTING SCREW LENGTH: PCB THICKNESS + (2.5±0.35)mm
- THIS CONNECTOR IS DESIGNED TO MEET THE REQUIREMENTS OF INDUSTRY SPECIFICATION SFF-8643.
- A  $\triangle$  SYMBOL WILL BE NEXT TO ANY DIMENSION, VIEW, OR NOTE THAT HAS BEEN MODIFIED WITH THE CURRENT DRAWING REVISION.

MATES WITH MINI-SAS HD ENDS IN:
10119217 SERIES (4i)
10119312 SERIES (4i)
10120086 SERIES (4i)
10120087 SERIES (4i)
10119576 SERIES (8i)
10119577 SERIES (8i)
10120088 SERIES (8i)
10120089 SERIES (8i)

spec ref	-	dr	Mark Gray	2010/08/04	projection	MM	size	A2	scale	4:1												
tolerance std	ASME Y14.5	eng	Jacklin Zou	2015/12/09			ecn no	ELX-DG-17937-1	rel level	Released												
		chr	Zhen Luo	2015/12/22																		
surface	<table border="1"> <tr><td>linear</td><td>0.X</td><td>±0.25</td></tr> <tr><td></td><td>0.XX</td><td>±0.15</td></tr> <tr><td></td><td>0.XXX</td><td>±</td></tr> <tr><td>angular</td><td>0°</td><td>±1/2°</td></tr> </table>	linear	0.X	±0.25		0.XX	±0.15		0.XXX	±	angular	0°	±1/2°	apppr	Pei-Ming Zheng	2015/12/23	product family	MINI-SAS HD	rel level	Released	rev	C
linear	0.X	±0.25																				
	0.XX	±0.15																				
	0.XXX	±																				
angular	0°	±1/2°																				
ASME Y14.5		www.fci.com			cat. no.		Product - Customer Drw	sheet 1 of 4														



# RECOMMENDED PCB BOARD LAYOUT

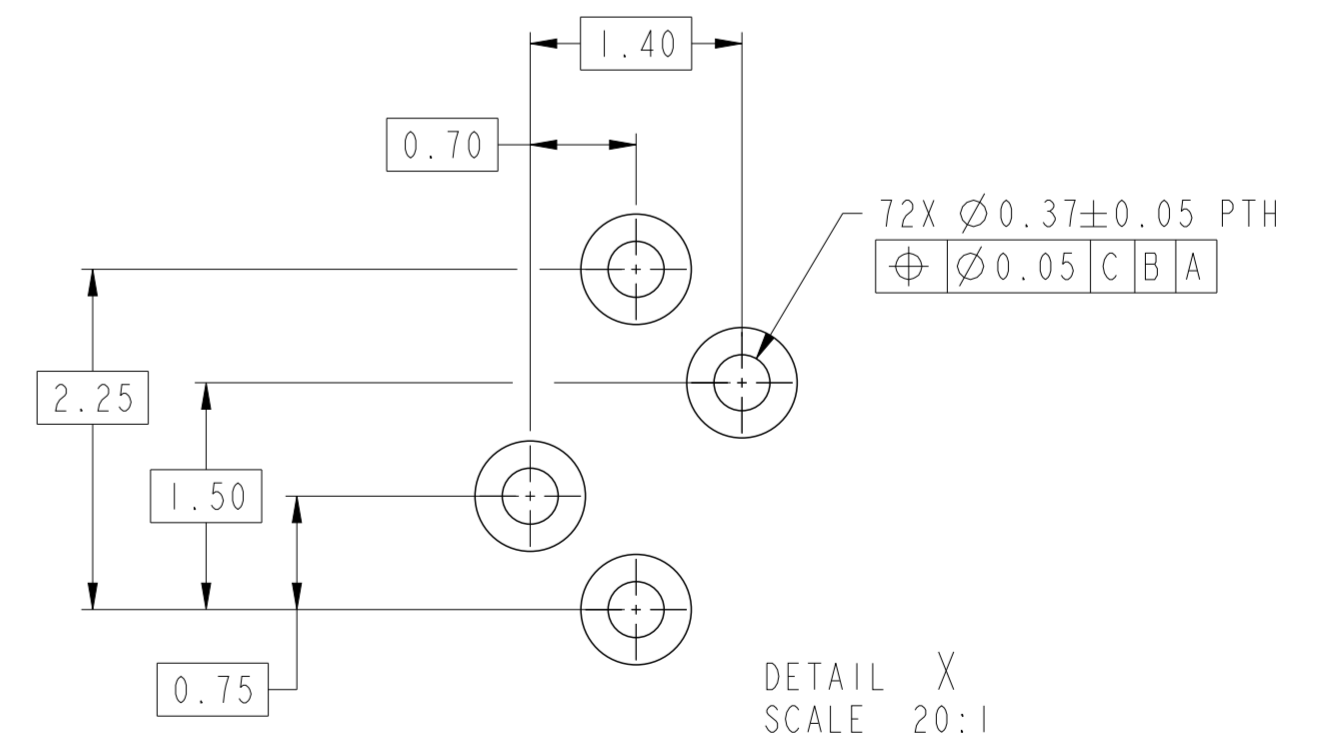
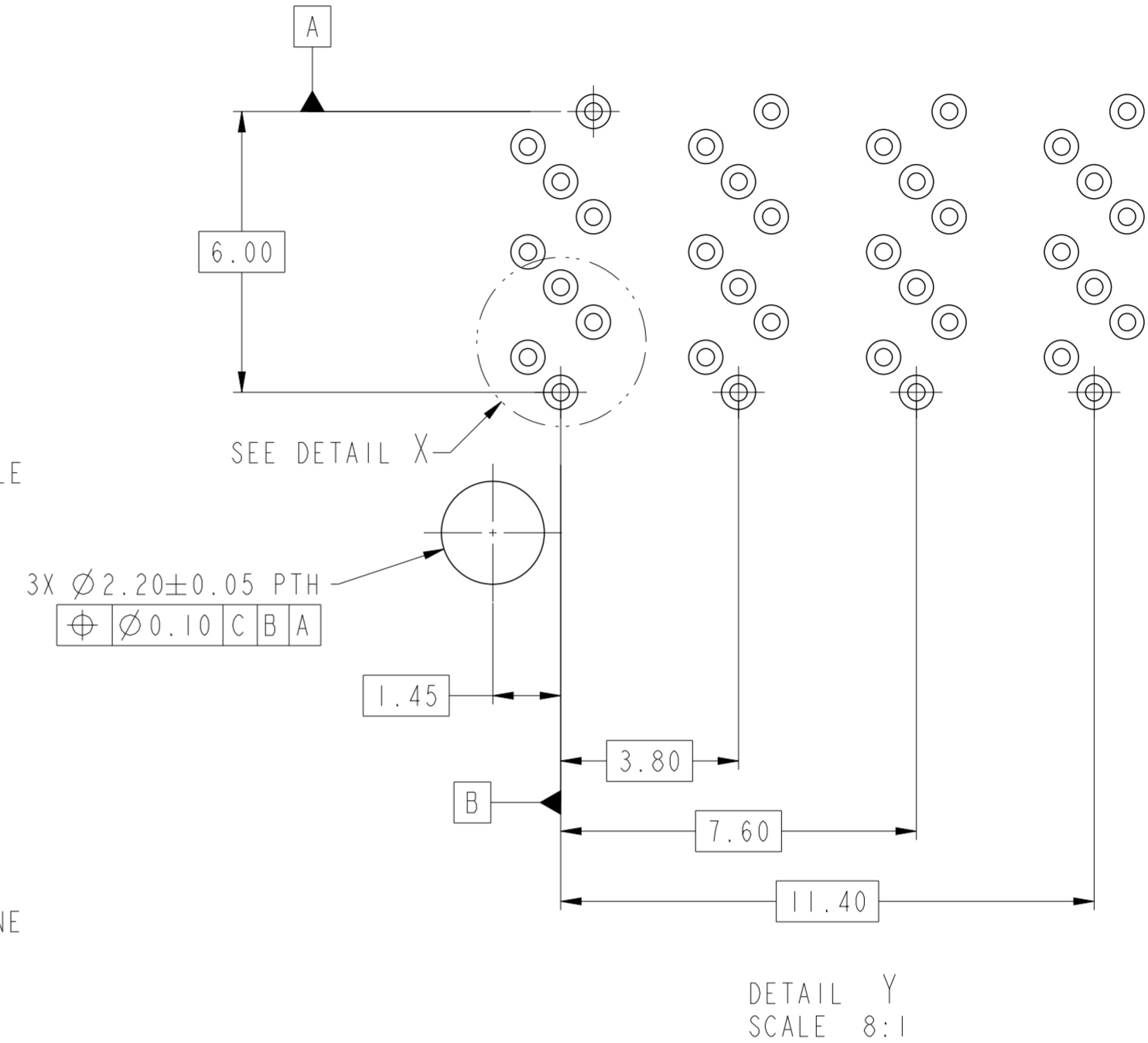
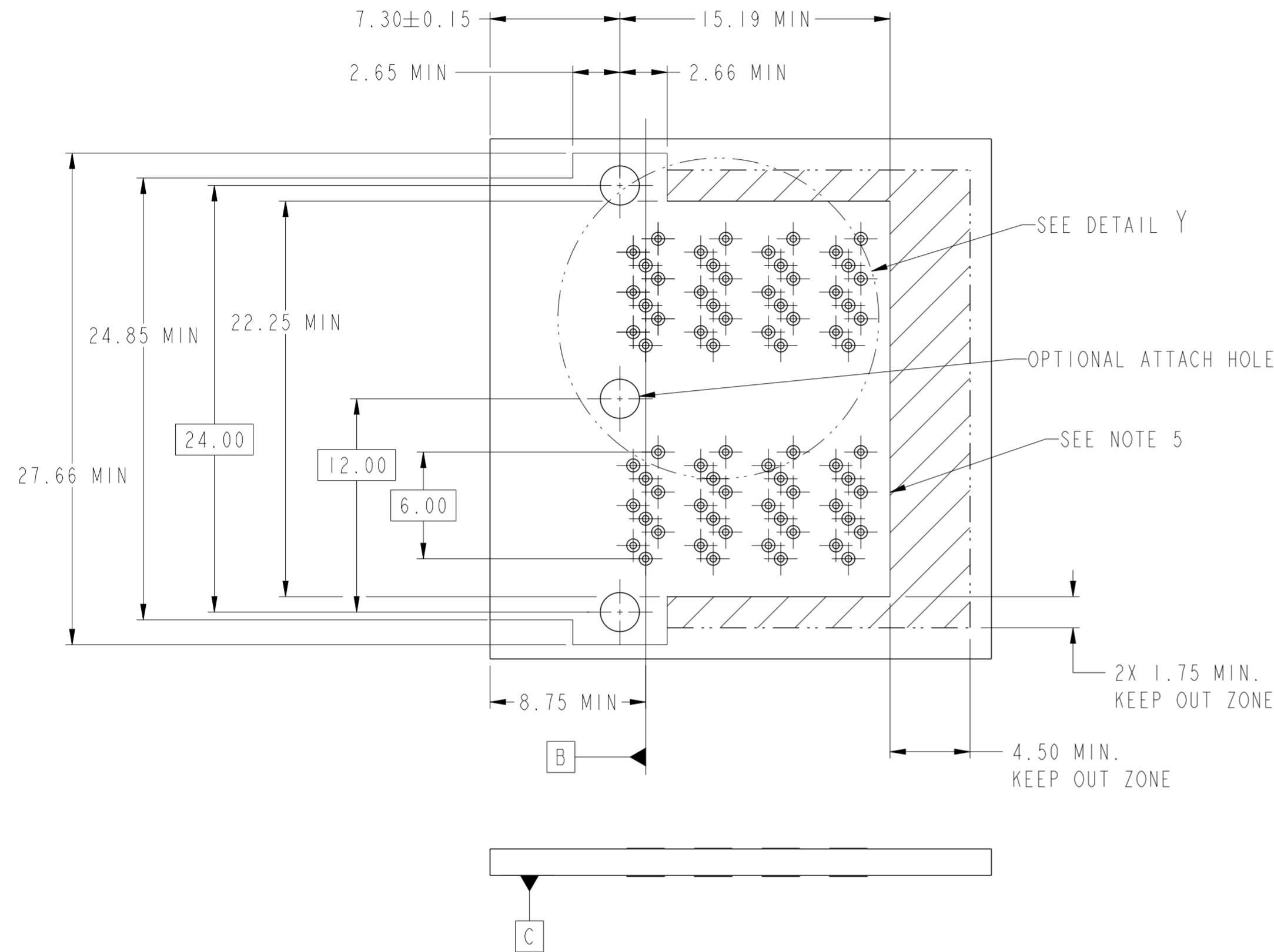

## NOTES:

1. RECOMMENDED DRILL SIZE FOR A Ø0.37 FINISHED PTH IS Ø0.457 (#77 DRILL).
2. RECOMMENDED ANNULAR RING AROUND Ø0.37 FINISHED PTH IS Ø0.73.
3. MINIMUM RECOMMENDED SPACING : 14.00mm.
4. MINIMUM PCB THICKNESS : 1.57mm.
5. CONNECTOR KEEP OUT AREA.

spec ref	-	dr	Mark Gray	2010/08/04	projection	MM	size	A2	scale	2:1		
tolerance std	ASME Y14.5	eng	Jacklin Zou	2015/12/09			ecn no	ELX-DG-17937-1				
TOLERANCES UNLESS OTHERWISE SPECIFIED		chr	Zhen Luo	2015/12/22			rel level	Released				
		appr	Pei-Ming Zheng	2015/12/23			product family	MINI-SAS HD				
surface	✓	linear	0.X	±0.25		TITLE IX2 INTERNAL ASSEMBLY MINI-SAS HD	dwg no 10112633	rev C	ASME Y14.5			
			0.XX	±0.15					cat. no.	Product - Customer Drw		sheet 2 of 4
		angular	0°	±1/2°								

# PIN OUT DESIGNATIONS

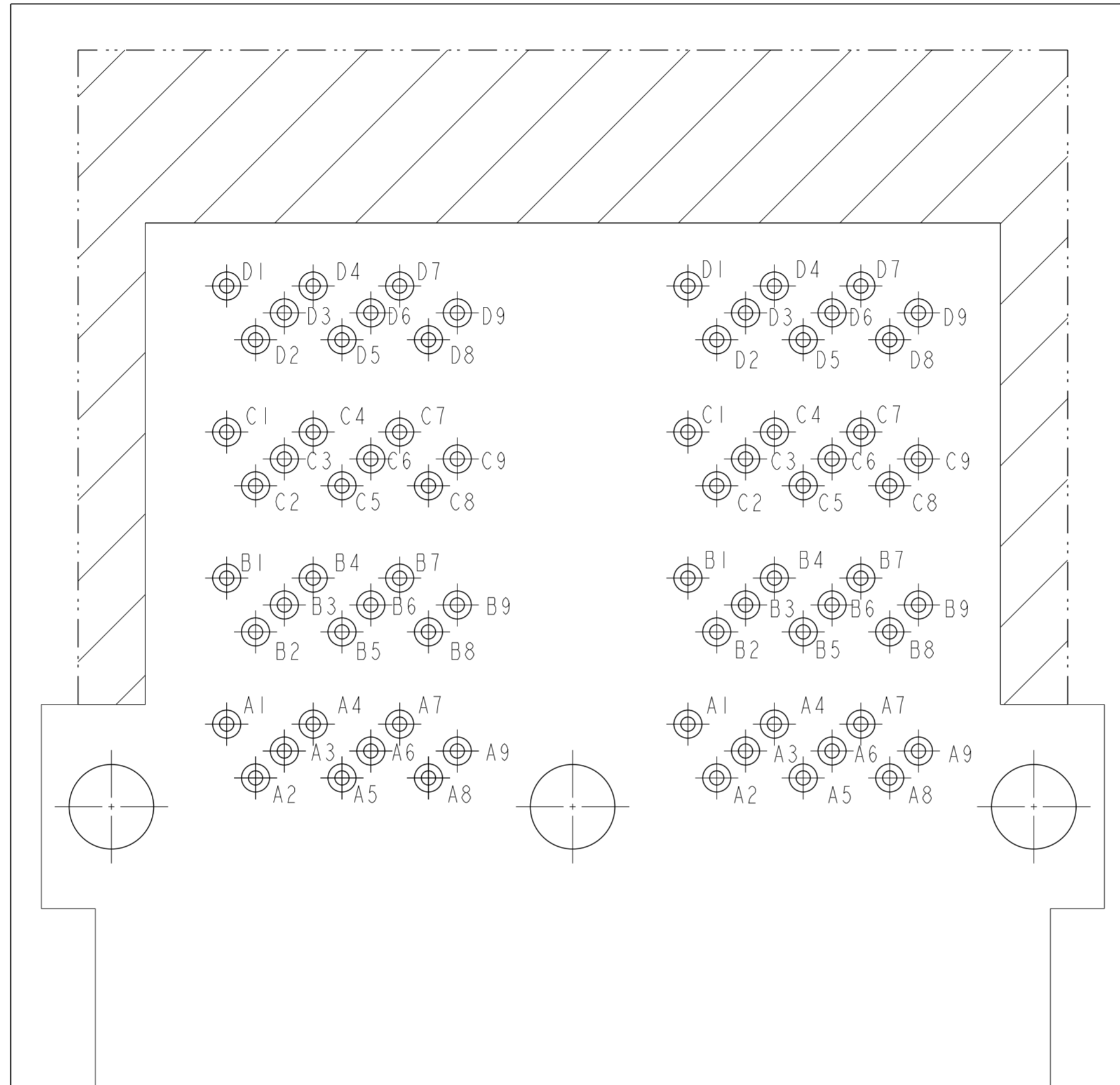

spec ref	-	dr	Mark Gray	2010/08/04	projection	MM	size	A2	scale	2:1												
tolerance std	ASME Y14.5	eng	Jacklin Zou	2015/12/09			ecn no	ELX-DG-17937-1	rel level	Released												
TOLERANCES UNLESS OTHERWISE SPECIFIED		chr	Zhen Luo	2015/12/22							product family	MINI-SAS HD										
surface	<table border="1"> <tr> <td>linear</td> <td>0.X</td> <td>±0.25</td> </tr> <tr> <td></td> <td>0.XX</td> <td>±0.15</td> </tr> <tr> <td></td> <td>0.XXX</td> <td>±</td> </tr> <tr> <td>angular</td> <td>0°</td> <td>±1/2°</td> </tr> </table>	linear	0.X	±0.25								0.XX	±0.15		0.XXX	±	angular	0°	±1/2°	appr	Pei-Ming Zheng	2015/12/23
linear	0.X	±0.25																				
	0.XX	±0.15																				
	0.XXX	±																				
angular	0°	±1/2°																				
ASME Y14.5		www.fci.com	cat. no.	-	Product - Customer Drw	sheet 3 of 4																



Copyright FCI.

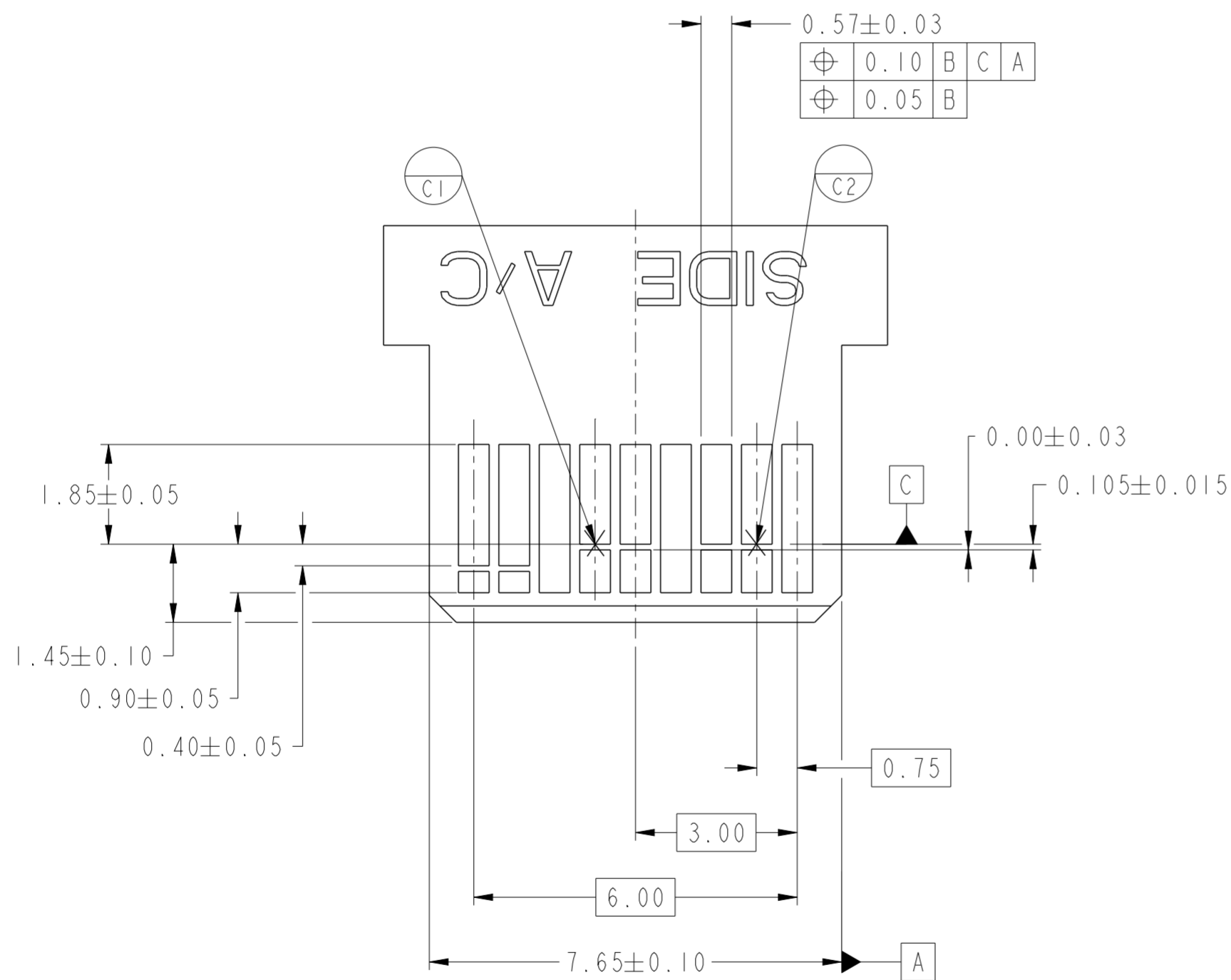
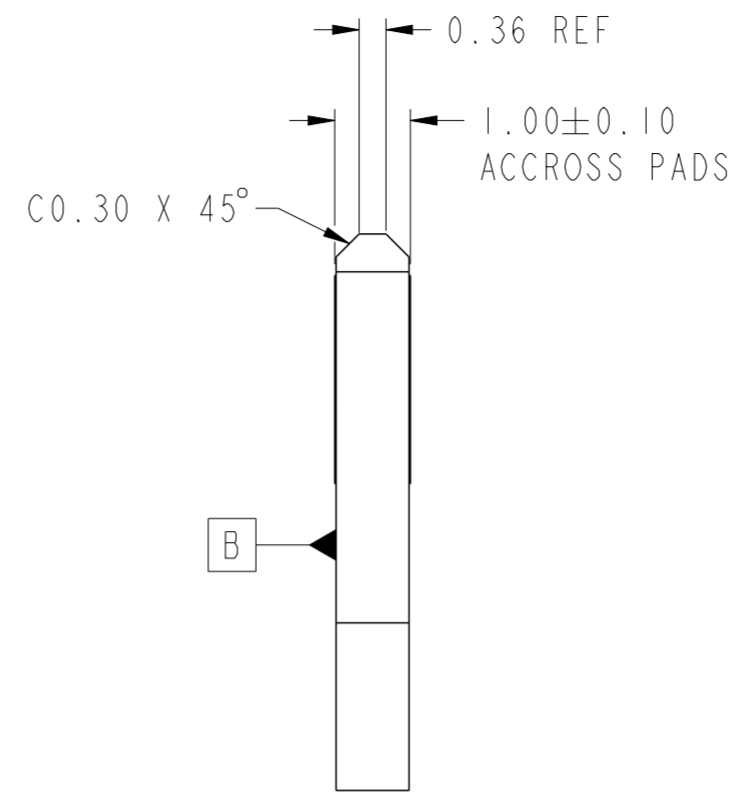
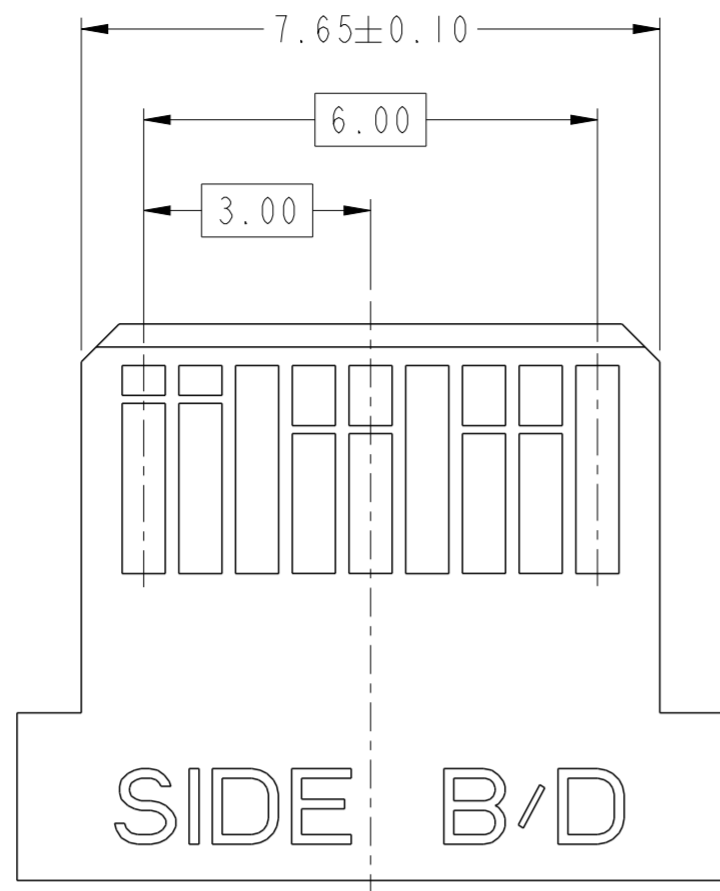

NOTES:

- 0.05 MINIMUM KEEP OUT SOLDER MASK AROUND ALL PADS.
- DATUM C TARGETS ARE DEFINED BY THE RESPECTIVE PAD CENTER LINES AND THE LEADING EDGE OF THE TARGET PADS.

spec ref	-	dr	Mark Gray	2010/08/04	projection	MM	size	A2	scale	2:1			
tolerance std	ASME Y14.5	eng	Jacklin Zou	2015/12/09			ecn no	ELX-DG-17937-1					
TOLERANCES UNLESS OTHERWISE SPECIFIED		chr	Zhen Luo	2015/12/22			rel level	Released					
		appr	Pei-Ming Zheng	2015/12/23			product family	MINI-SAS HD					
surface	✓	linear	0.X	±0.25		title IX2 INTERNAL ASSEMBLY MINI-SAS HD	dwg no 10112633	rev C	ASME Y14.5 angular 0° ±1/2°				
			0.XX	±0.15					www.fci.com cat. no.		Product - Customer Drw		sheet 4 of 4
			0.XXX	±									

