



Chipsmall Limited consists of a professional team with an average of over 10 year of expertise in the distribution of electronic components. Based in Hongkong, we have already established firm and mutual-benefit business relationships with customers from,Europe,America and south Asia,supplying obsolete and hard-to-find components to meet their specific needs.

With the principle of "Quality Parts,Customers Priority,Honest Operation,and Considerate Service",our business mainly focus on the distribution of electronic components. Line cards we deal with include Microchip,ALPS,ROHM,Xilinx,Pulse,ON,Everlight and Freescale. Main products comprise IC,Modules,Potentiometer,IC Socket,Relay,Connector.Our parts cover such applications as commercial,industrial, and automotives areas.

We are looking forward to setting up business relationship with you and hope to provide you with the best service and solution. Let us make a better world for our industry!



Contact us

Tel: +86-755-8981 8866 Fax: +86-755-8427 6832

Email & Skype: info@chipsmall.com Web: www.chipsmall.com

Address: A1208, Overseas Decoration Building, #122 Zhenhua RD., Futian, Shenzhen, China

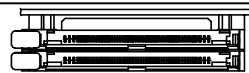

DESCRIPTION : ABOVE PCB, DECK AND PUSH ROD LOCATION ARE AS VIEW BY USER.

PRODUCT NO.	PUSH ROD LOCATION		STAND-OFF HEIGHT		CLOSEST TO PCB	FARTHEST FROM PCB	MATING RECEPTACLE	P.C.B SIDE	RECOMMENDED P.C.B LAYOUT	MOUNT STYLE TO PCB AND PUSH ROD SIDE
	DECK CLOSEST TO PCB	DECK FARTHEST TO PCB	DECK CLOSEST TO PCB	DECK FARTHEST TO PCB	EJ HDR ASS'Y	EJ HDR ASS'Y				
Ⓐ 10114582-xxxxxxx					Ⓑ	Ⓒ	Ⓓ			
8501CALF	LEFT	LEFT	5.0	0.5	61125-650CALF	10114583-615CALF	RECEPTACLE PART NO. 91931-31169LF	BELOW	(SEE PAGE 2)	

PART NUMBER DESCRIPTION :

10114582-□□□□□□□□

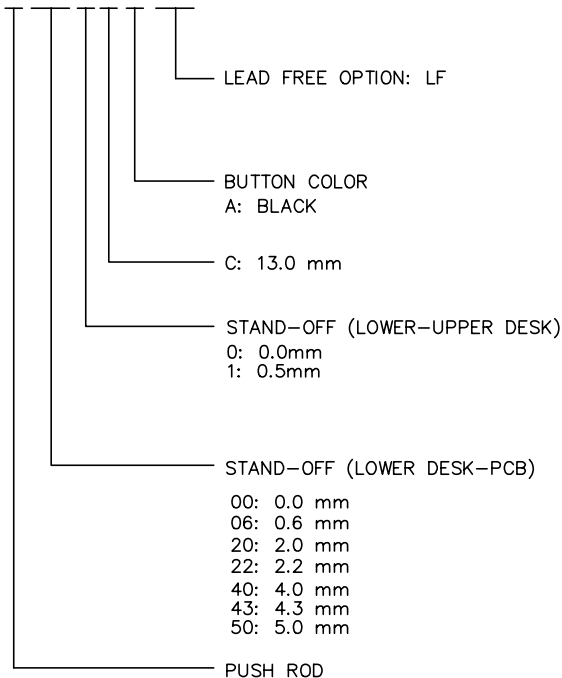

NOTES:

1. THE HOUSING WILL WITHSTAND EXPOSURE TO 260°C PEAK TEMPERATURE FOR 10 SECONDS IN A WAVE SOLDER APPLICATION WITH A 1.00MM MINIMUM THICK CIRCUIT BOARD.
2. THE PRODUCTS FOR SUFFIX " LF " MEET EUROPEAN UNION DIRECTIVES AND OTHER COUNTRY REGULATIONS AS DESCRIBED IN GS-22-008 OTHER PRODUCTS ARE COMPLIANT EXCEPT FOR Pb.
3. LEAD FREE P/N PACKAGING MEETS GS-14-920 SPECIFICATION
4. FINISH (PIN)
UNDER PLATING: 1.27 um MIN. Ni
CONTACT AREA: 0.076 um MIN. GOLD
SOLDER TAIL: 2.5 um MIN. MATTE PURE Sn
5. PRODUCT SPEC 110-263
6. PACKAGE SPEC GS-14-341

TOP MOUNT		BOTTOM MOUNT	
0: RIGHT-LEFT	5: RIGHT-LEFT		
1: LEFT-RIGHT	6: LEFT-RIGHT		
2: RIGHT-RIGHT	7: RIGHT-RIGHT		
3: LEFT-LEFT	8: LEFT-LEFT		

rev	ecn no	dr	date
1	-	-	-
2	-	SH	2010-12-21
A	N11-0095	SH	2011-05-05
B	ELX-N-011457	ZK	2012-04-02
-	-	-	-
-	-	-	-
-	-	-	-

www.fciconnect.com			surface 6.4 / tolerance std ISO 1302 / ISO 406 ISO 1101	projection	MM
			TOLERANCES UNLESS OTHERWISE SPECIFIED		↔
Dr	SH MIAO	2011-05-05	ANGULAR	0.X	±0.3
Eng	SH MIAO	2011-05-05	LINEAR	0.XX	±0.15
Chr	RICK BIAN	2011-05-05	0° ±2°	0.XXX	±0.05
Appr	JOSEPH HSIA	2011-05-05	Product family		10114582
Spec ref					N11-0095
title				dwg no	Rev.
EJECTOR HEADER ASS'Y 3.3V SMT, TYPE 1/2/3				10114582	B
catalog no				CUSTOMER	sheet 1 of 2



Copyright FCI.

1

2

3

4

(A) PART NUMBER	DIM.L	DIM.S	DIM.A
10114582-8501CALF	5.0	-0.3	89.05

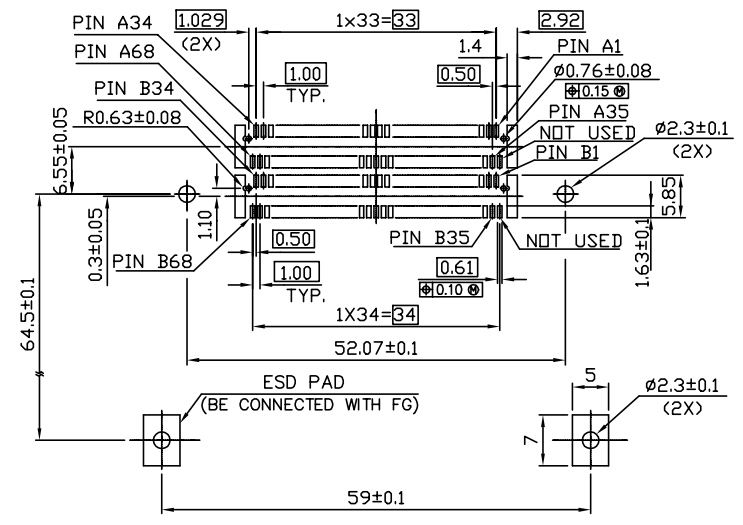
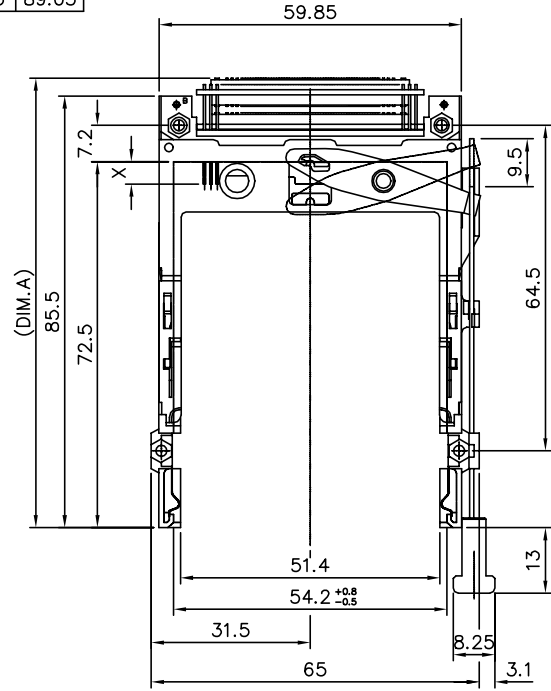
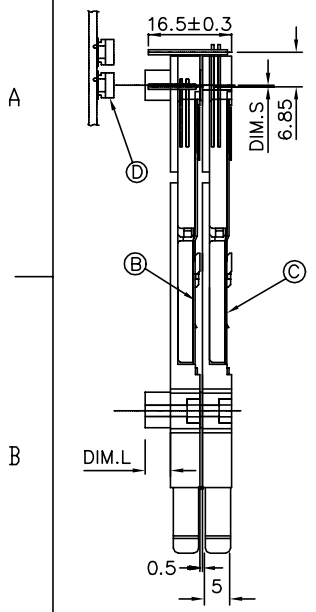

4 CARD INSERTION DIRECTION
RECOMMENDED P.C.B. LAYOUT (MOUNTED SIDE)

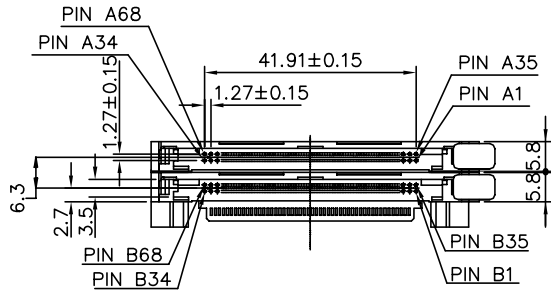

Copyright FCI.

www.fciconnect.com			surface 6.4 ISO 1302	tolerance std ISO 406 ISO 1101	projection MM	MM
			TOLERANCES UNLESS OTHERWISE SPECIFIED			
Dr	SH MIAO	2011-05-05	ANGULAR	0.X	±0.3	size A4
Eng	SH MIAO	2011-05-05	LINEAR	0.XX	±0.15	Scale 1.000
Chr	RICK BIAN	2011-05-05	0° ±2°	0.XXX	±0.05	ECN N11-0095
Appr	JOSEPH HSIA	2011-05-05	Product family 10114582		Spec ref	
FCI			title EJECTOR HEADER ASS'Y 3.3V SMT, TYPE 1/2/3		dwg no 10114582	
			catalog no		CUSTOMER sheet 2 of 2	

REV F - 2006-04-17

1

2

3

4

PDS: Rev :B

STATUS:Released

Printed: Sep 12, 2013