



Chipsmall Limited consists of a professional team with an average of over 10 year of expertise in the distribution of electronic components. Based in Hongkong, we have already established firm and mutual-benefit business relationships with customers from,Europe,America and south Asia,supplying obsolete and hard-to-find components to meet their specific needs.

With the principle of “Quality Parts,Customers Priority,Honest Operation,and Considerate Service”,our business mainly focus on the distribution of electronic components. Line cards we deal with include Microchip,ALPS,ROHM,Xilinx,Pulse,ON,Everlight and Freescale. Main products comprise IC,Modules,Potentiometer,IC Socket,Relay,Connector.Our parts cover such applications as commercial,industrial, and automotives areas.

We are looking forward to setting up business relationship with you and hope to provide you with the best service and solution. Let us make a better world for our industry!



## Contact us

Tel: +86-755-8981 8866 Fax: +86-755-8427 6832

Email & Skype: info@chipsmall.com Web: www.chipsmall.com

Address: A1208, Overseas Decoration Building, #122 Zhenhua RD., Futian, Shenzhen, China



PART NUMBER  
10120045-200LF

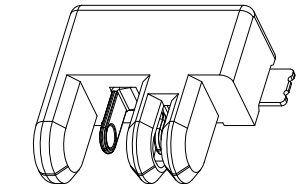
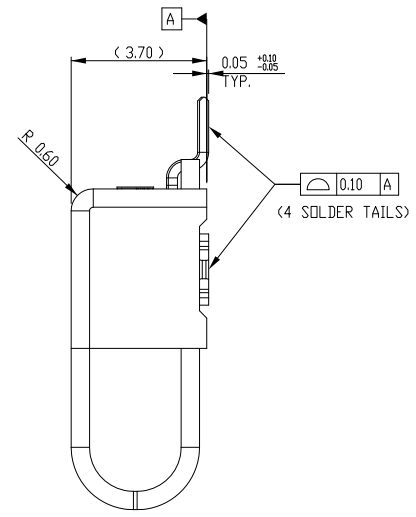
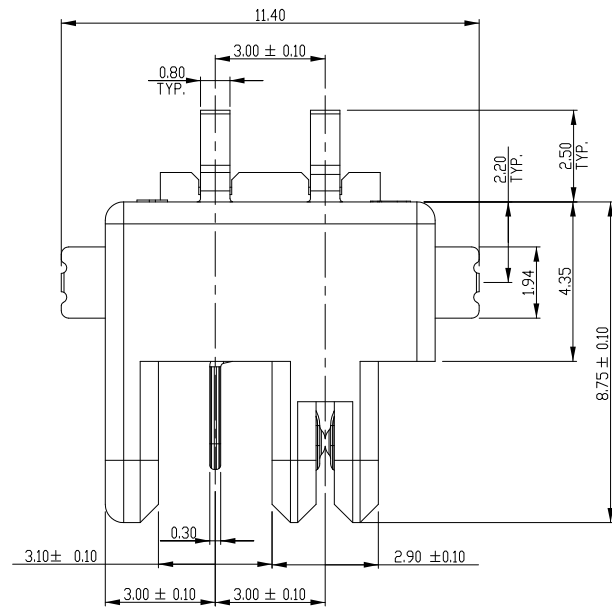

SCALE 3.000

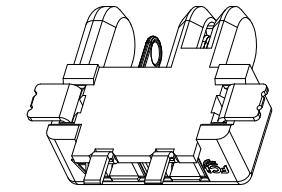

SCALE 3.000

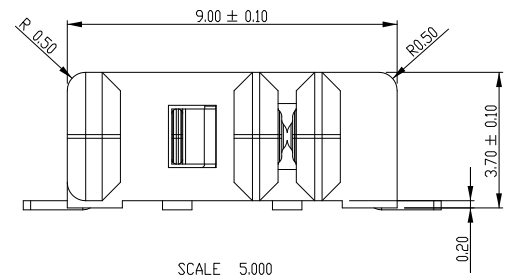

SCALE 5.000

NOTES:  
 1. MATERIAL:  
 HOUSING: HIGH TEMPERATURE LCP,NATURAL  
 UL 94 V-0 FLAME RETARDANT.  
 CONTACTS: COPPER ALLOY.  
 PLATING SPEC AS BELOW:  
 FOR CONTACT AREA:  
 \* 0.76um GXT™ (30°GXT™);  
 FOR SOLDER AREA:  
 MATTE PURE TIN 3 um MIN.  
 FOR UNDERPLATING:  
 1.27 um MIN.THICKNESS NICKEL  
 2. PRODUCT SPEC. GS-12-1079.  
 3. LEAD FREE NOTES:  
 3a.THE HOUSING WILL WITHSTAND EXPOSURE TO 260°C PEAK  
 TEMPERATURE FOR 10 SECONDS IN A CONVECTION, INFRA-RED  
 OR VAPOR PHASE REFLOW OVEN.  
 3b.THIS PRODUCT MEETS EUROPEAN UNION DIRECTIVES AND  
 OTHER COUNTRY REGULATIONS AS DESCRIBED IN GS-22-008.  
 \* GXT™ is an FCI Electronics patented process of palladium-nickel alloy plated with a gold flash.



Copyright FCI.

rev	ecn no	dr	date
A	-	MJA	2013-06-10
-	-	-	-
-	-	-	-
-	-	-	-
-	-	-	-
-	-	-	-

www.fciconnect.com		surface ISO 1302	tolerance std ISO 406 ISO 1101	projection MM
Dr	M JACOB	2013-06-10	ANGULAR	size A4
Eng	M JACOB	2013-06-10	LINEAR	Scale 5.000
Chr	M JACOB	2013-06-10	0° ±2°	ECN -
Appr	BIJU K PAUL	2013-06-10	Product family-RotaConnect Spec ref -	
FCI		title ASSEMBLY, 2 POS HDR TYPE ROTATABLE BOARD TO BOARD CONNECTOR		part no 10120045-200C
		catalog no : 10120045-200LF		Rev. A
				CUSTOMER DRAWING sheet 1 of 3

PART NUMBER  
10120045-200LF

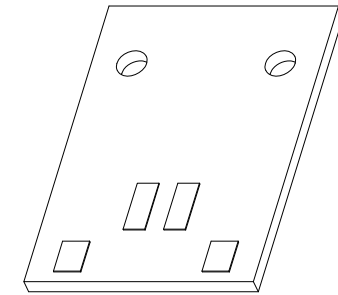

SCALE 2.000

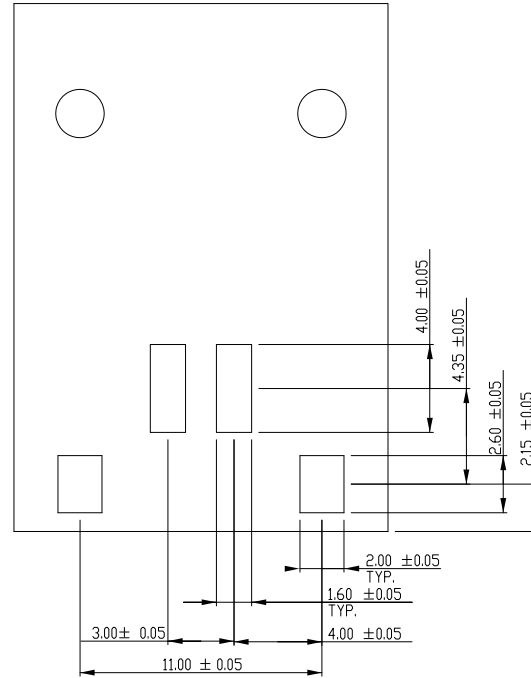

SCALE 3.000



Copyright FCI.

www.fciconnect.com			surface ISO 1302	tolerance std ISO 406 ISO 1101	projection MM		
			TOLERANCES UNLESS OTHERWISE SPECIFIED				
Dr	M JACOB	2013-06-10	ANGULAR	0.X	±X	size	A4
Eng	M JACOB	2013-06-10	LINEAR	0.XX	±0.2	Scale	3.000
Chr	M JACOB	2013-06-10	0° ±2°	0.XXX	±X	ECN	-
Appr	BIJU K PAUL	2013-06-10	Product family-RotaConnect			Spec ref	-
			title			no	
			ASSEMBLY, 2 POS HDR TYPE			10120045-200C	
			ROTATABLE BOARD TO BOARD CONNECTOR			Rev.	
			catalog no : 10120045-200LF			A	
			CUSTOMER DRAWING			sheet 2 of 3	

rev	ecn no	dr	date
-	-	-	-
-	-	-	-
-	-	-	-
-	-	-	-
-	-	-	-
-	-	-	-
-	-	-	-

PART NUMBER  
10120045-200LF

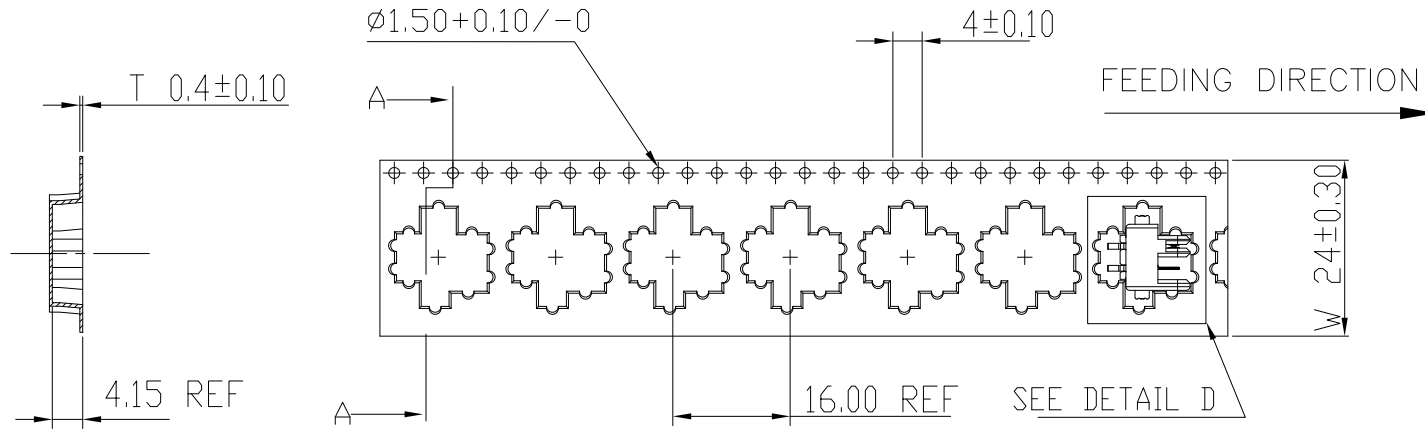

SECTION A-A

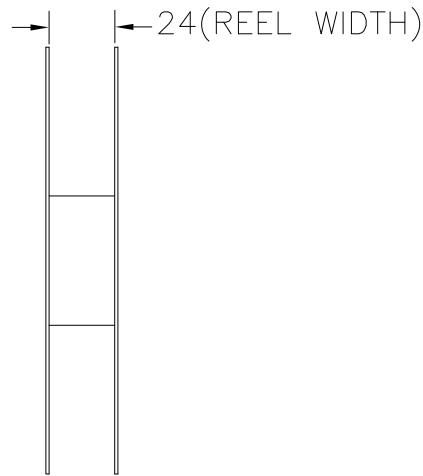
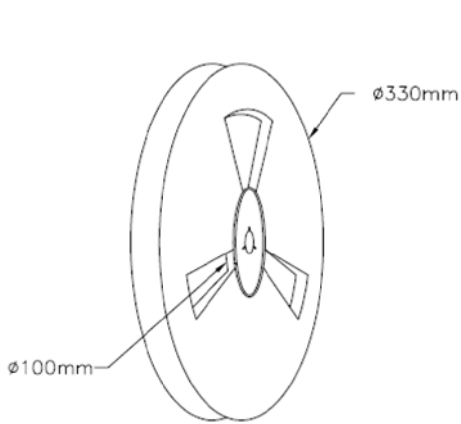

Component inside carrier tape

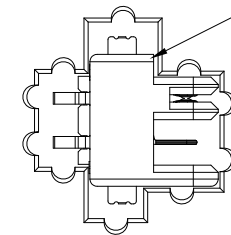

DETAIL D  
SCALE 2:1

NOTES :

1. MATERIAL : ANTI-STATIC POLYSTYRENE
2. PACKAGING AS PER EIA-481 STD.
3. QTY PER REEL : 975 NOS

rev	ecn no	dr	date
-	-	-	-
-	-	-	-
-	-	-	-
-	-	-	-
-	-	-	-

www.fciconnect.com			surface ISO 1302	tolerance std ISO 406 ISO 1101	projection MM
Dr	M JACOB	2013-06-10	ANGULAR	0.X ±X	size A4
Eng	M JACOB	2013-06-10	LINEAR	0.XX ±0.2	Scale 1.000
Chr	M JACOB	2013-06-10	0° ±2°	0.XXX ±X	ECN -
Appr	BIJU K PAUL	2013-06-10	Product family	Spec ref -	
			title ASSEMBLY, 2 POS HDR TYPE ROTATABLE BOARD TO BOARD CONNECTOR		no 10120045-200C Rev. A
catalog no : 10120045-200LF			CUSTOMER DRAWING sheet 3 of 3		