



Chipsmall Limited consists of a professional team with an average of over 10 year of expertise in the distribution of electronic components. Based in Hongkong, we have already established firm and mutual-benefit business relationships with customers from,Europe,America and south Asia,supplying obsolete and hard-to-find components to meet their specific needs.

With the principle of "Quality Parts,Customers Priority,Honest Operation,and Considerate Service",our business mainly focus on the distribution of electronic components. Line cards we deal with include Microchip,ALPS,ROHM,Xilinx,Pulse,ON,Everlight and Freescale. Main products comprise IC,Modules,Potentiometer,IC Socket,Relay,Connector.Our parts cover such applications as commercial,industrial, and automotives areas.

We are looking forward to setting up business relationship with you and hope to provide you with the best service and solution. Let us make a better world for our industry!



Contact us

Tel: +86-755-8981 8866 Fax: +86-755-8427 6832

Email & Skype: info@chipsmall.com Web: www.chipsmall.com

Address: A1208, Overseas Decoration Building, #122 Zhenhua RD., Futian, Shenzhen, China



PRODUCT NUMBER	STAND OFF
10120751-015LF	1.5MM

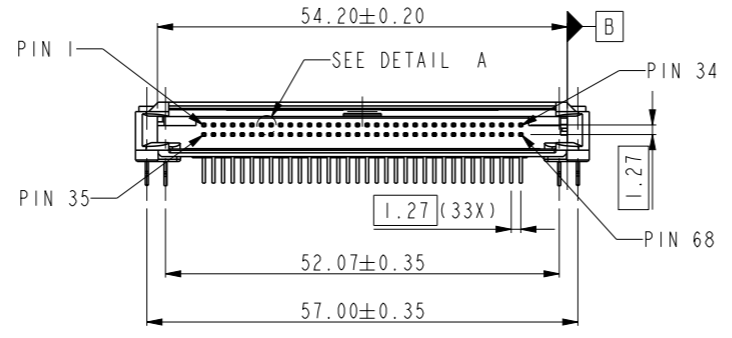
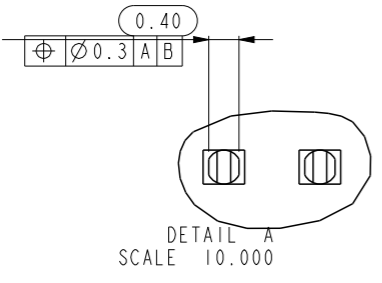
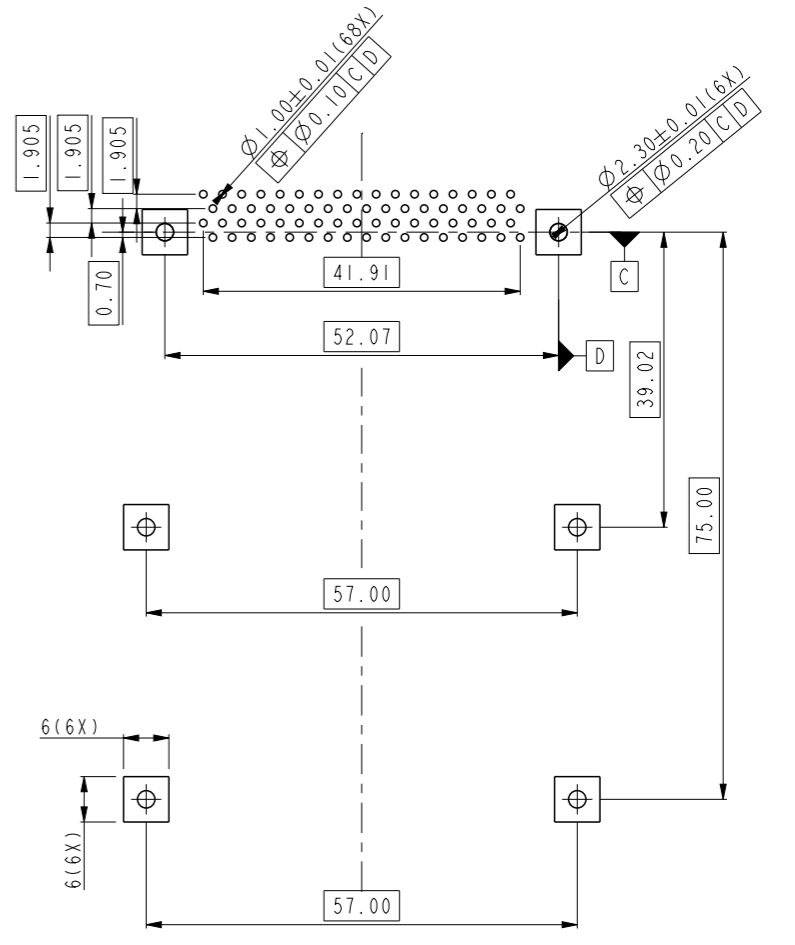
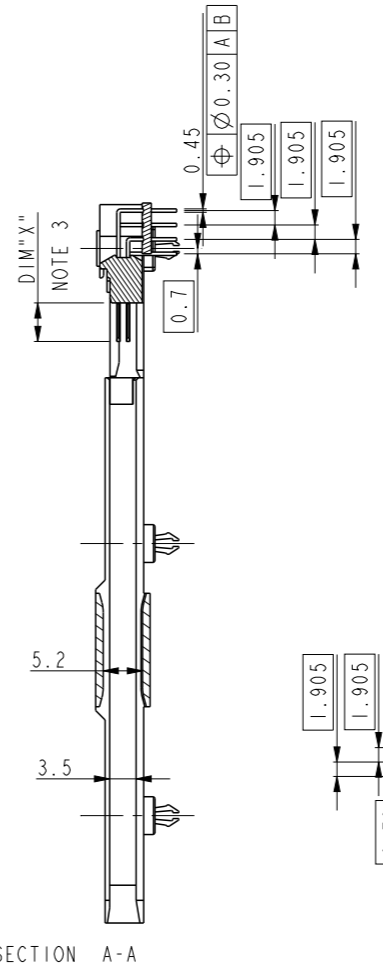
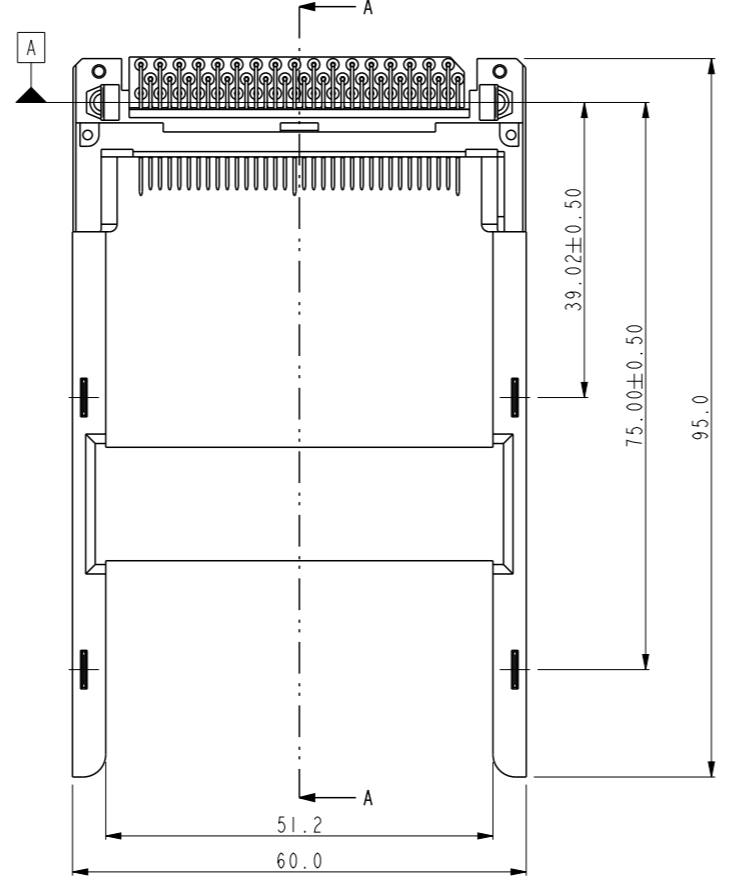
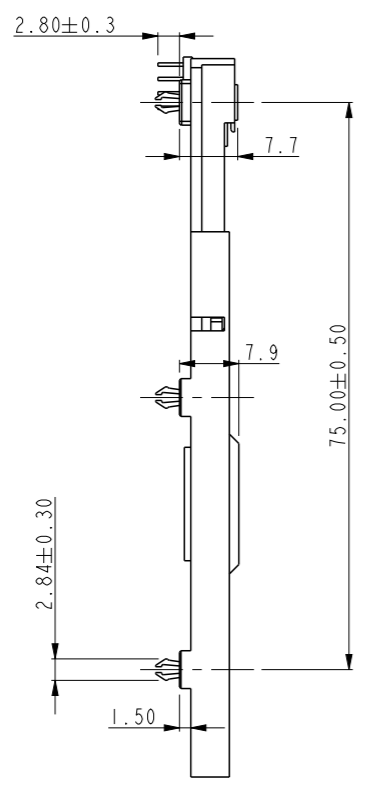

- NOTES:
- MATERIAL:
HOUSING : HIGH TEMPERATURE THERMOPLASTIC, UL94-V0 BLACK.
PIN: COPPER ALLOY
 - FINISH(PIN)
2-1. Ni UNDER PLATING 1.27MM THICKNESS MIN. ALL OVER
2-2. 0.076uM Au MIN. AT CONTACT AREA
2-3. PURE TIN PLATING 2.5uM THICKNESS MIN.
 - | | | | |
|------------|--------|----------|-----------------------|
| PIN NUMBER | OTHERS | 36, 37 | 1, 17, 34, 35, 51, 68 |
| DIM"X" | | 4.25±0.1 | 3.5±0.1 |
| | | | 5.0±0.1 |
 - THIS PART WILL WITHSTAND EXPOSURE TO 260°C PEAK TEMPERATURE FOR 10 SECOND IN A WAVE SOLDER APPLICATION WITH 1.60MM MINIMUM THICK CIRCUIT BOARD.
 - THIS PART MEETS EUROPEAN UNION DIRECTIVES AND OTHER COUNTRY REGULATIONS AS DESCRIBED IN GS-22-008
 - PRODUCT SPEC: 110-263.

spec ref	-	dr	Zheng-Kun Hu	2013/03/12
tolerance std	ISO 406 ISO 1101	eng	Zheng-Kun Hu	2013/03/13
	TOLERANCES UNLESS OTHERWISE SPECIFIED	chr	-	-
surface	linear	appr	Rick Bian	2013/03/13
	angular			

projection	MM	size	A3	scale	1.000
product family	-	ecn no	-	rel level	Released
title	68POS 3.3V PCMCIA ASSEMBLY		dwg no	10120751	rev
	HALOGEN-FREE PRODUCT				A
cat. no.	-	Product - Customer Drw	sheet 1 of 1		



Copyright FCI.