



Chipsmall Limited consists of a professional team with an average of over 10 year of expertise in the distribution of electronic components. Based in Hongkong, we have already established firm and mutual-benefit business relationships with customers from,Europe,America and south Asia,supplying obsolete and hard-to-find components to meet their specific needs.

With the principle of “Quality Parts,Customers Priority,Honest Operation,and Considerate Service”,our business mainly focus on the distribution of electronic components. Line cards we deal with include Microchip,ALPS,ROHM,Xilinx,Pulse,ON,Everlight and Freescale. Main products comprise IC,Modules,Potentiometer,IC Socket,Relay,Connector.Our parts cover such applications as commercial,industrial, and automotives areas.

We are looking forward to setting up business relationship with you and hope to provide you with the best service and solution. Let us make a better world for our industry!



Contact us

Tel: +86-755-8981 8866 Fax: +86-755-8427 6832

Email & Skype: info@chipsmall.com Web: www.chipsmall.com

Address: A1208, Overseas Decoration Building, #122 Zhenhua RD., Futian, Shenzhen, China



PRODUCT NUMBER	TAIL PLATING OPTION, SEE NOTE 2	1X2 EXTERNAL ASSEMBLY	1X2 LIGHT PIPE SUB-ASSEMBLY WITH MOUNTING CLIP	DESCRIPTION
10120959-101	OPTION 1	10112627-101	10121257-001LF	WITH SAME LENGTH LIGHT PIPES
10120959-101LF	OPTION 2	10112627-101LF		
10120959-102LF	OPTION 2	10112627-101LF	10121257-002LF	WITH DIFFERENT LENGTH LIGHT PIPES

NOTES:

- MATERIALS:**
CONNECTOR HOUSING: HIGH TEMPERATURE THERMOPLASTIC
GLASS FILLED, UL 94V-0
EMI CAGE: NICKEL SILVER ALLOY
EMI FINGERS: COPPER ALLOY
TERMINALS: COPPER ALLOY
LIGHT PIPE CLIP: STAINLESS STEEL
LIGHT PIPE: POLYCARBONATE
- FINISHES:**
EMI FINGERS: 0.50um MIN NICKEL
CONTACT AREA: 0.76um MIN GOLD OVER 2.54um MIN NICKEL
TAIL AREA:
OPTION 1: 0.76um - 1.52um TIN/LEAD (90/10) OVER 2.54um MIN NICKEL
OPTION 2: 0.76um - 1.52um TIN (LEAD FREE) OVER 2.54um MIN NICKEL
- PRODUCT SPECIFICATION:** GS-12-651
- PRODUCT PACKING SPECIFICATION:** GS-14-1490
EXTERNAL ASSEMBLY WILL BE IN ONE BOX.
LIGHT PIPE SUB-ASSEMBLY WITH MOUNTING CLIP WILL BE IN ONE BOX.
BOTH BOXES WILL BE IN A MASTER CARTON.
- APPLICATION SPECIFICATION:** GS-20-0327
- MOUNTING HARDWARE:** M2X0.4 BUTTON HEAD SCREW
MOUNTING SCREW LENGTH: BOARD THICKNESS + 1.4mm MAX (0.9mm MIN).
2 REQUIRED PER ASSEMBLY.
MOUNTING HARDWARE NOT SUPPLIED.
- THIS CONNECTOR IS DESIGNED TO MEET THE REQUIREMENTS OF INDUSTRY SPECIFICATION SFF-8644.**
- LIGHT PIPE SUB-ASSEMBLY WITH MOUNTING CLIP FINAL ASSEMBLY AFTER EXTERNAL ASSEMBLY APPLIED TO PCB.**
- A \triangle B SYMBOL WILL BE NEXT TO ANY DIMENSION, VIEW, OR NOTE THAT HAS BEEN MODIFIED WITH THE CURRENT DRAWING REVISION.**

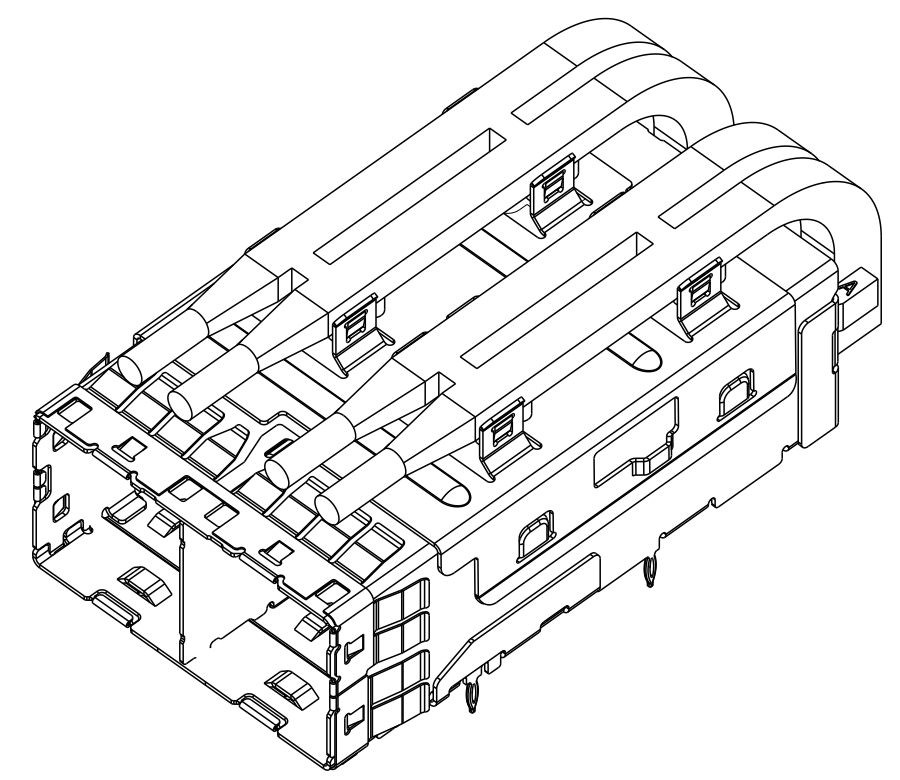
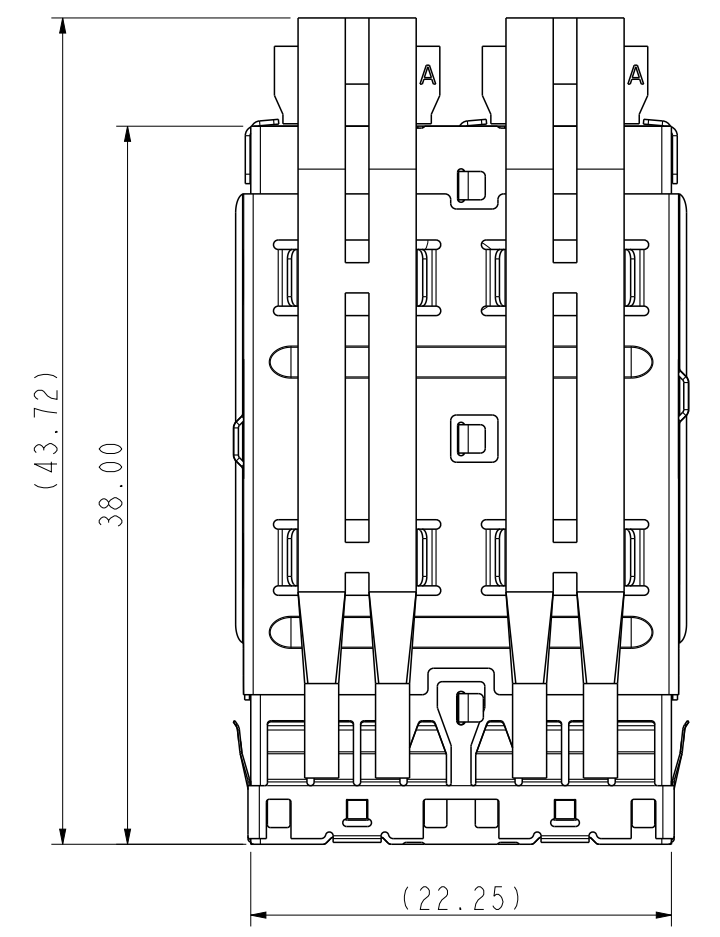

10120959-101 & 101LF SHOWN WITH SAME LENGTH LIGHT PIPES SCALE 2.500

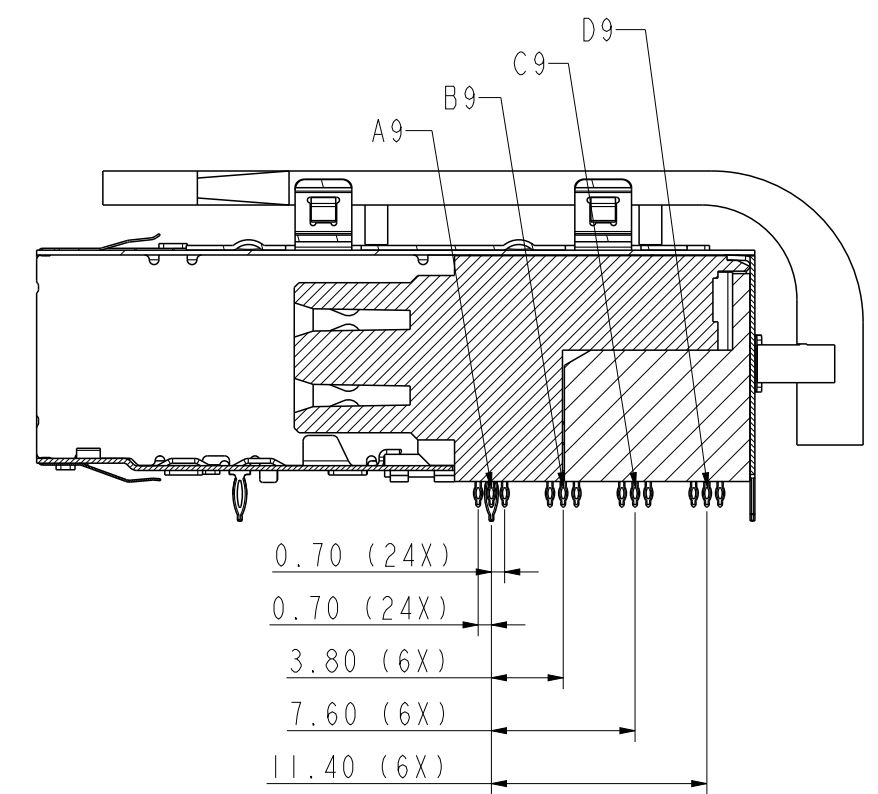
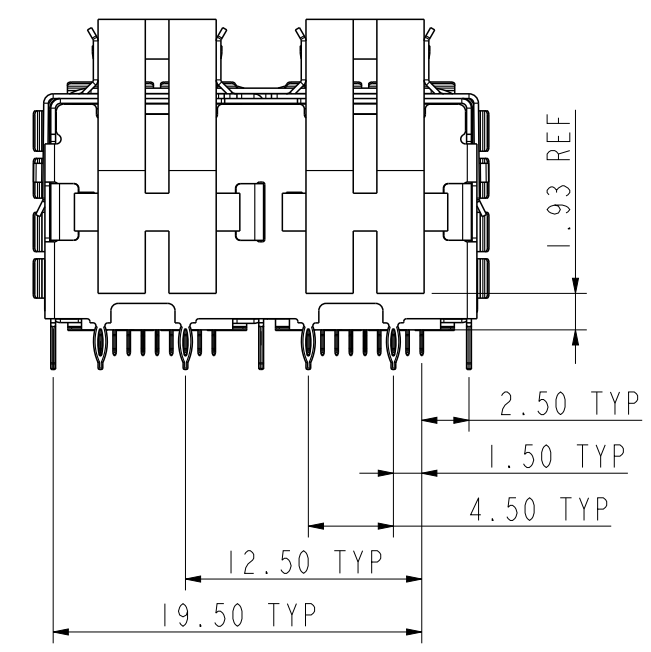
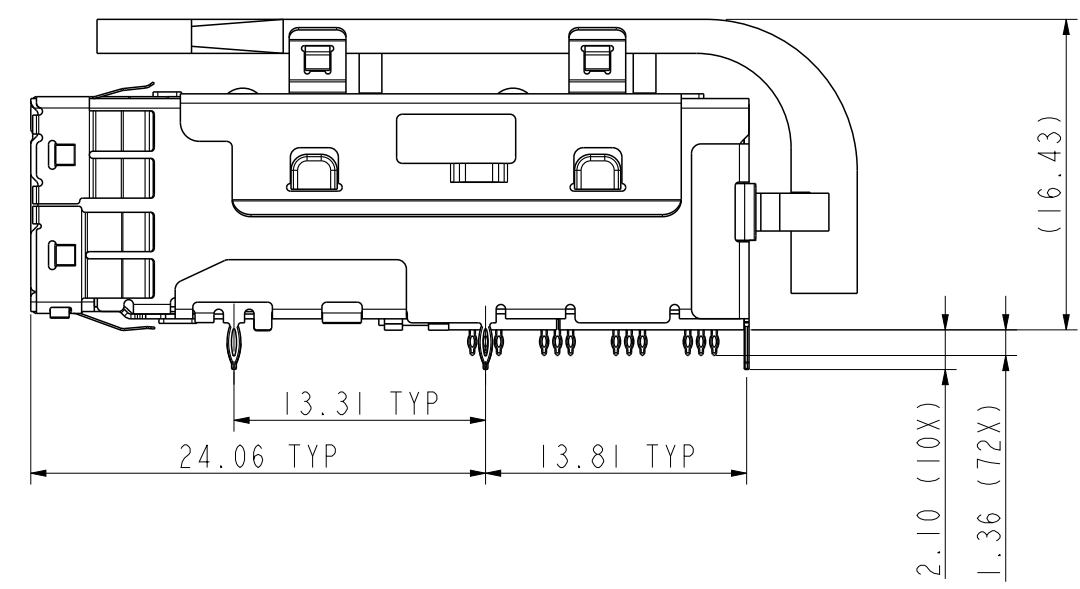
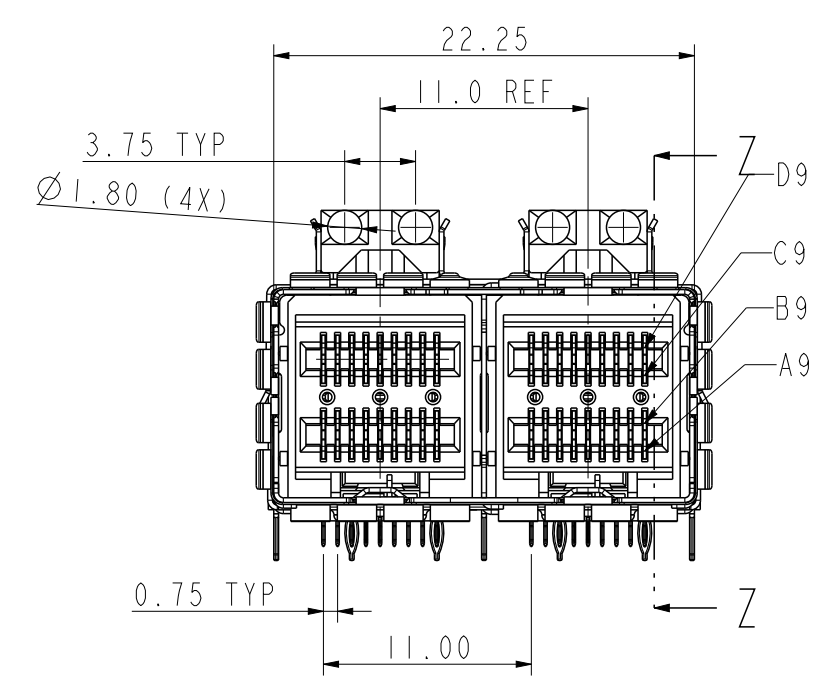

SECTION Z-Z

MATES WITH MINI-SAS HD ENDS IN:

10112041 SERIES (4X)
10117771 SERIES (4X)
10117946 SERIES (4X)
10117949 SERIES (4X)
10117947 SERIES (8X)
10112359 SERIES (8X)
10117950 SERIES (8X)
10117948 SERIES (8X)

spec ref	-	dr	Qin De-Feng	2012/11/21	projection	MM	size	A2	scale	2.500
tolerance std	ISO 406 ISO 1101	eng	Jerry Zhang	2018/01/15			ecn no	ELX-DG-28824-1	rel level	Released
surface	-	chr	Stone Li	2018/01/15						
		appr	Heaven Cen	2018/01/18			cat. no.	Product - Customer Drw		sheet 1 of 7
		Amphenol FCI www.fci.com		TITLE 1X2 EXTERNAL ASSEMBLY WITH LIGHT PIPE MINI-SAS HD		dwg no 10120959	rev B			

PDS: Rev :B

STATUS:Released

Printed: Jan 18, 2018

Amphenol FCI

© 2016 AFCI

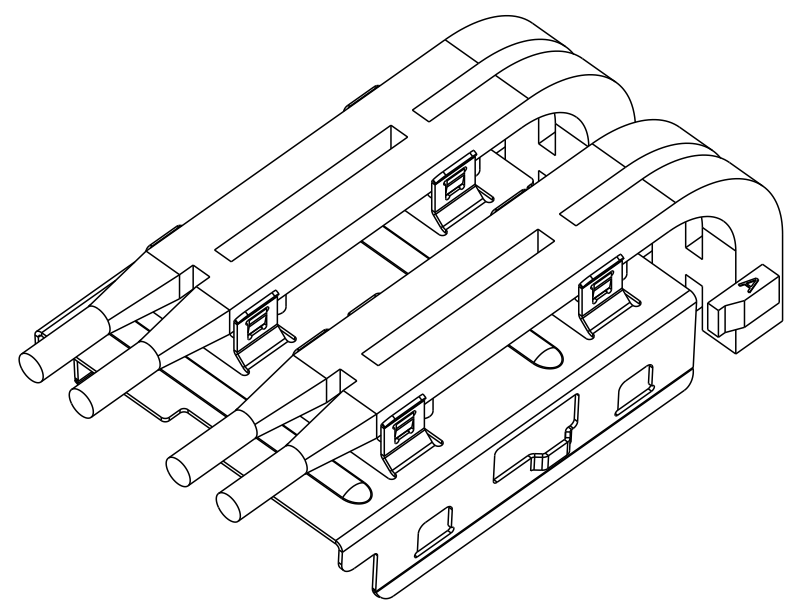

1X2 LIGHT PIPE SUB-ASSEMBLY
WITH MOUNTING CLIP
10121257-001LF SHOWN

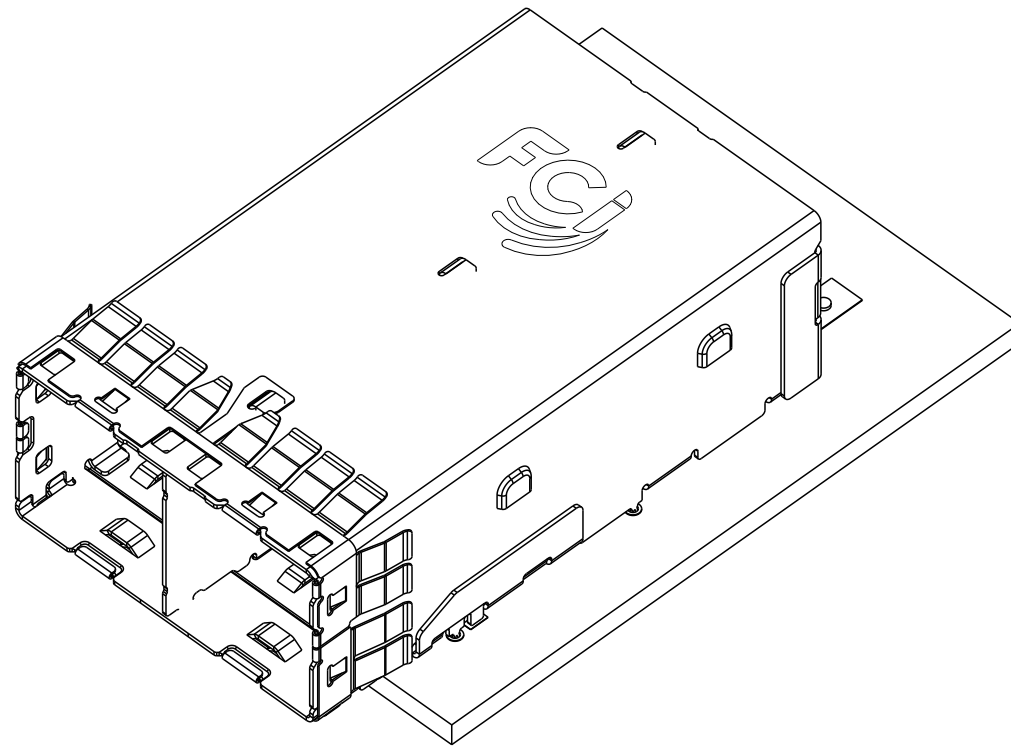

1X2 EXTERNAL ASSEMBLY
APPLIED TO PCB
10112627-101 & 101LF

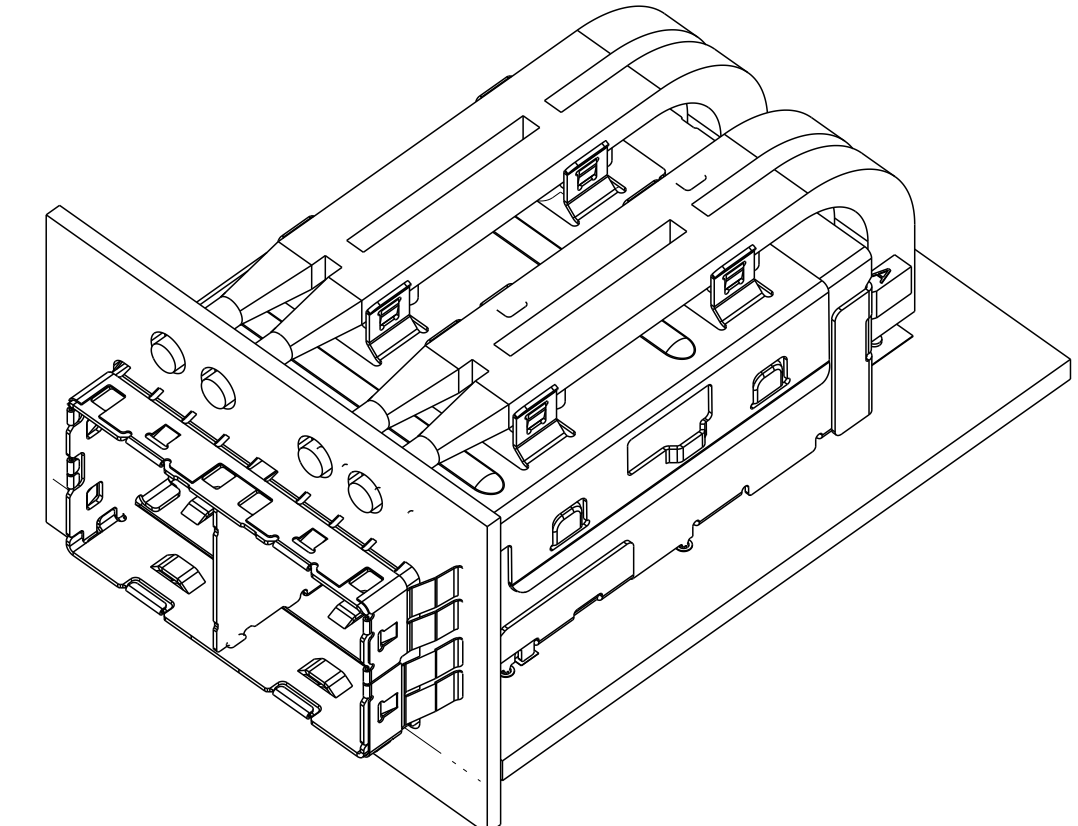

1X2 LIGHT PIPE SUB-ASSEMBLY
APPLIED TO CONNECTOR
10120959-101 & 101LF SHOWN
(LIGHT PIPE SUB-ASSEMBLY
FINAL ASSEMBLY BY CUSTOMER)

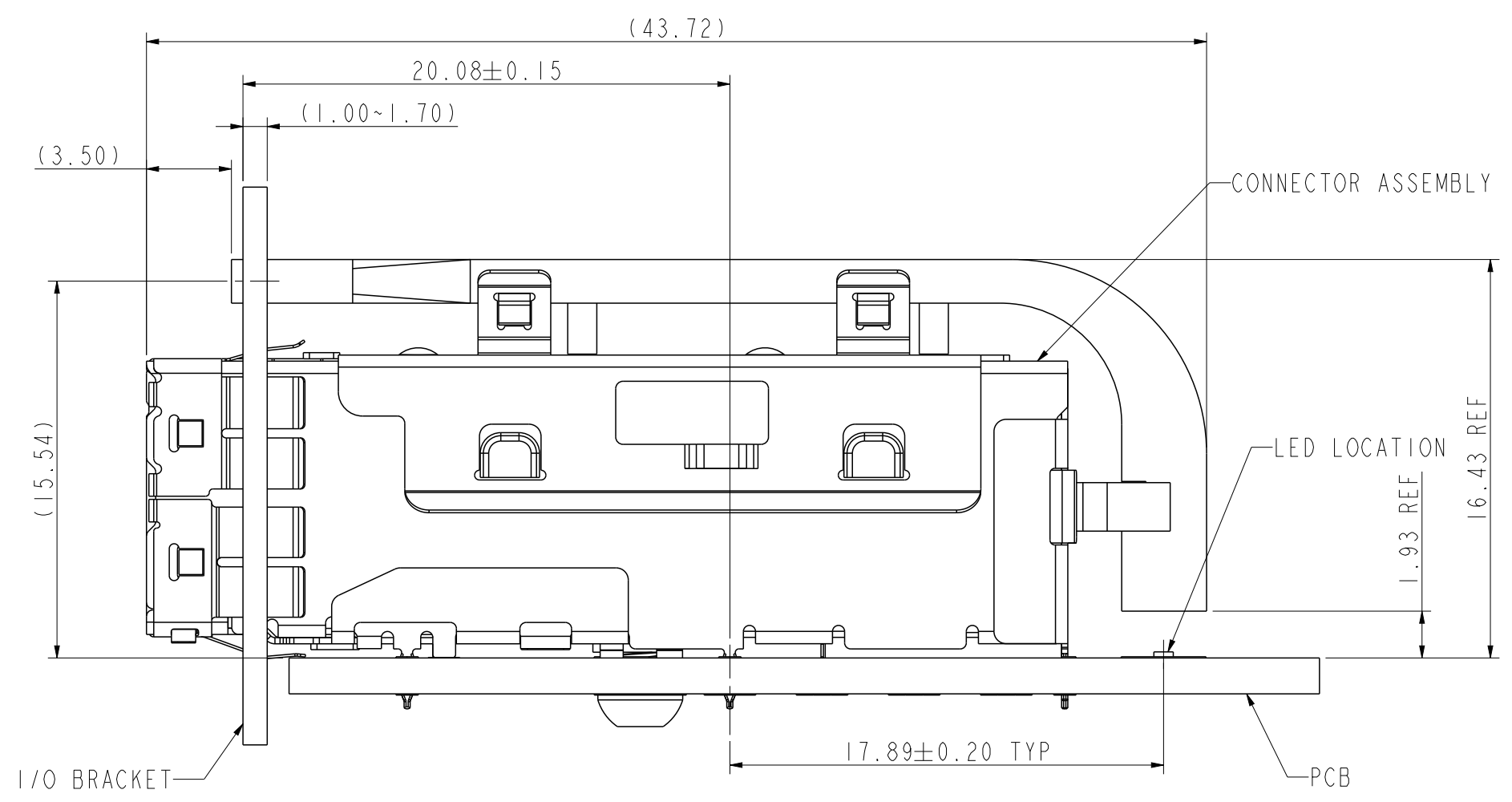

10120959-101 & 101LF ASSEMBLED VIEW
WITH SAME LENGTH LIGHT PIPES
SCALE 4.000

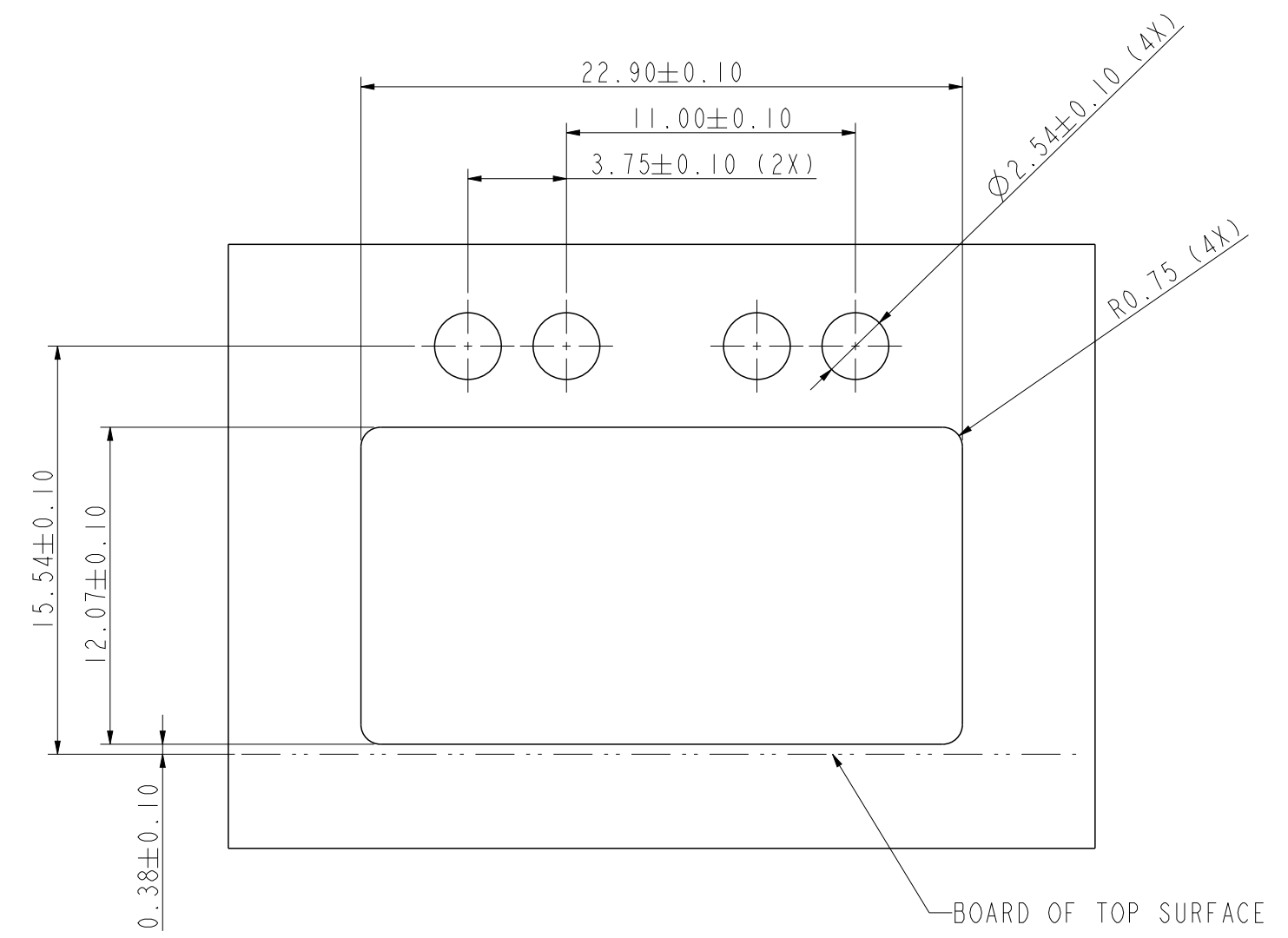

I/O BRACKET CUT OUT
(BRACKET NOT INCLUDED)
SCALE 4.000

Amphenol
FCI

© 2016 APCI

spec ref	-	dr	Qin De-Feng	2012/11/21	projection	MM	size	A2	scale	2.500
tolerance std	ISO 406 ISO 1101	eng	Jerry Zhang	2018/01/15			ecn no	ELX-DG-28824-1	rel level	Released
TOLERANCES UNLESS OTHERWISE SPECIFIED		chr	Stone Li	2018/01/15			product family	MINI-SAS HD		
surface	-	appr	Heaven Cen	2018/01/18			cat. no.	10120959	rev	B
ISO 1302	linear	0.X	±0.5	www.fci.com		Product - Customer Drw	sheet 2 of 7			
		0.XX	±0.3							
		0.XXX	±							
	angular	0°	±3°							

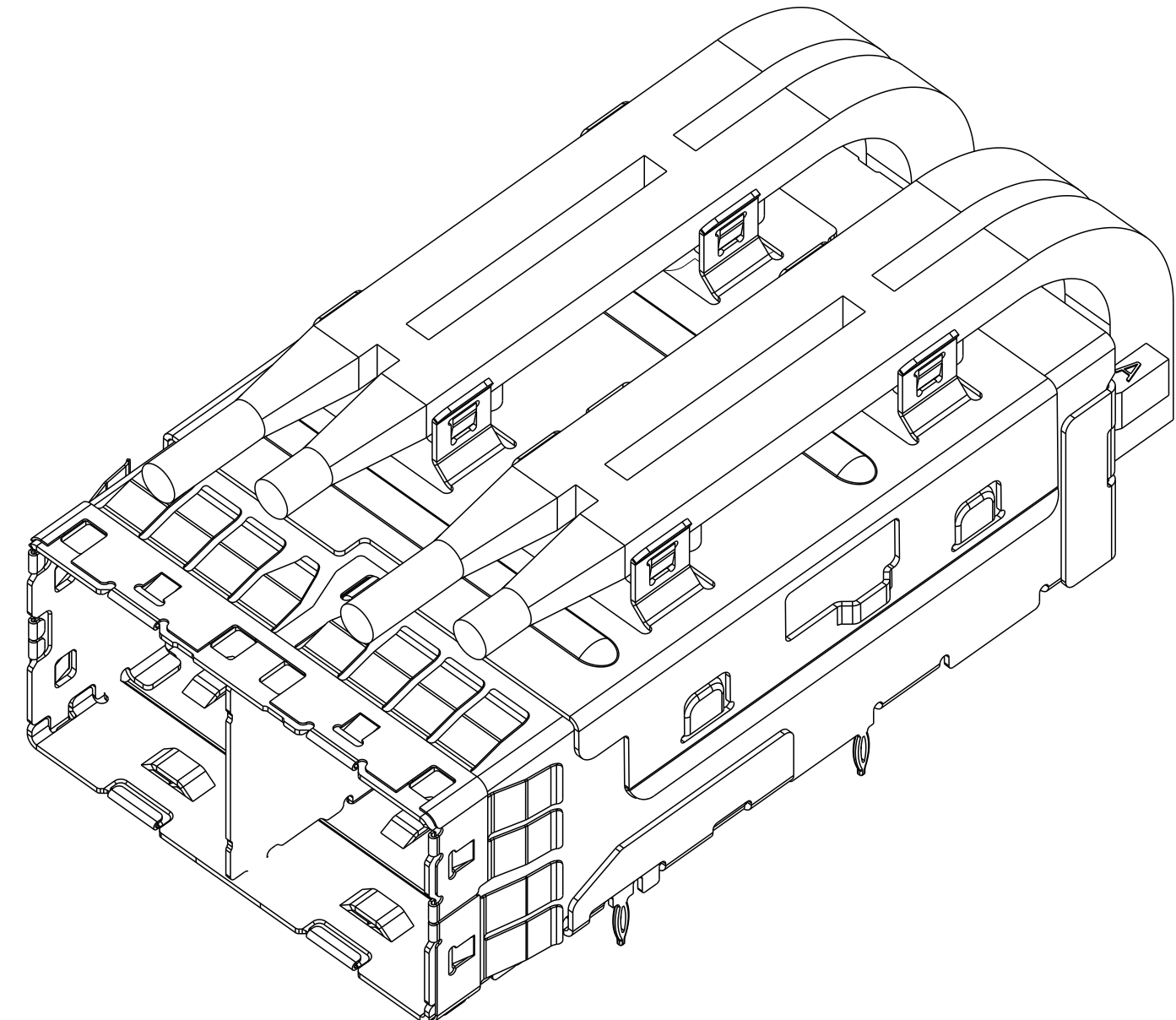
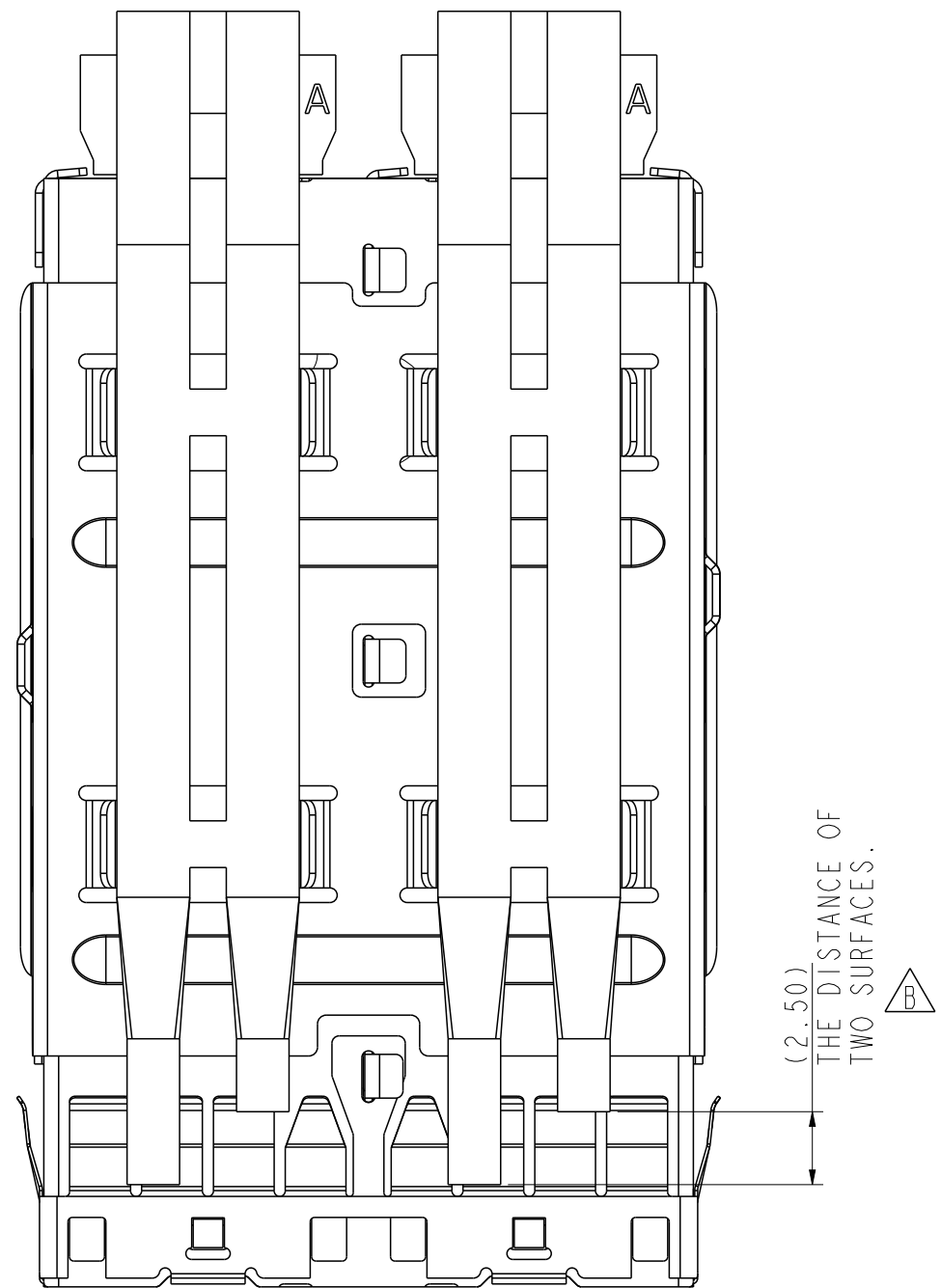

10120959-102LF SHOWN
WITH DIFFERENT LENGTH LIGHT PIPES
SCALE 4.000

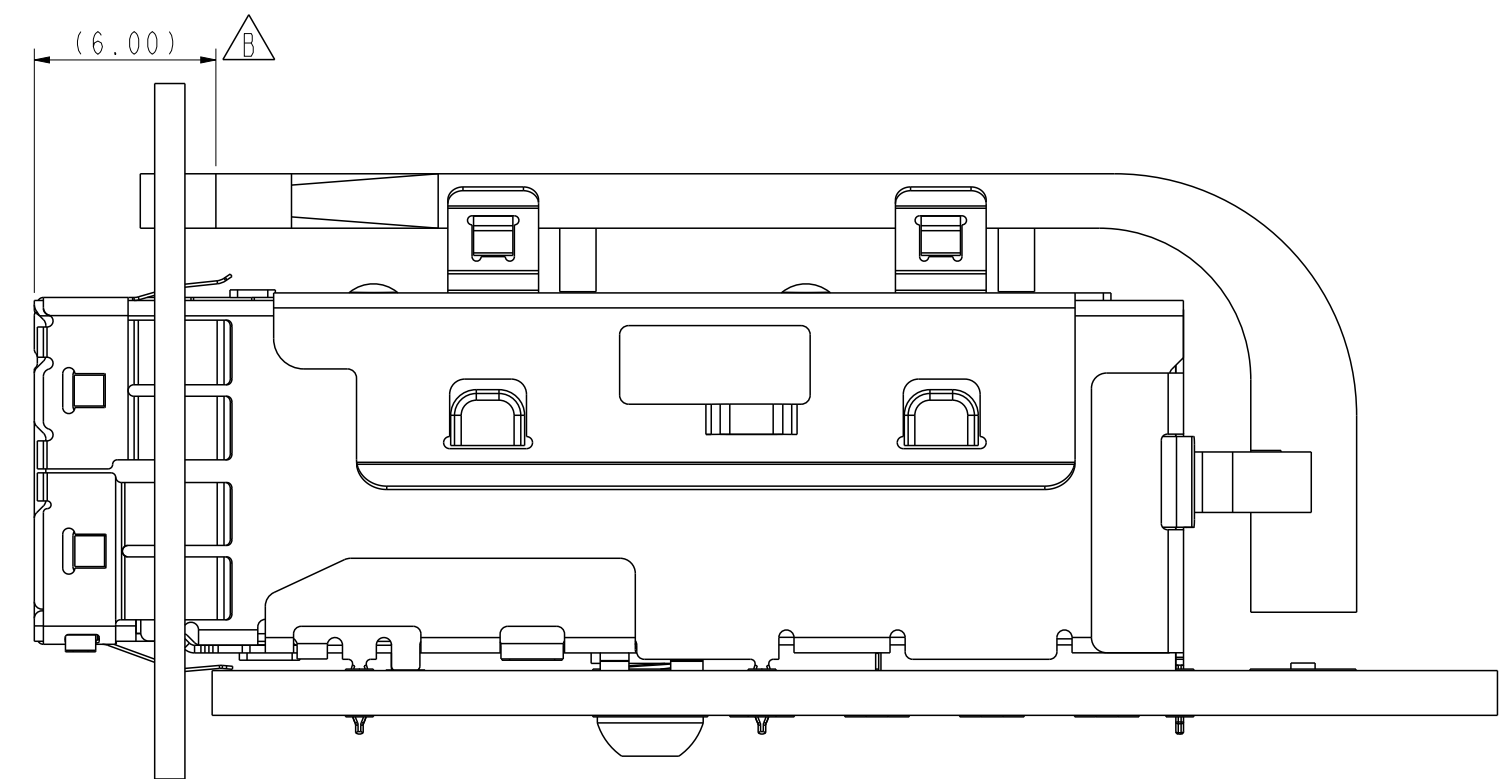

10120959-102LF ASSEMBLED VIEW
WITH DIFFERENT LENGTH LIGHT PIPES
SCALE 4.000

ALL DIMENSIONS ARE SAME AS 10120959-101LF EXCEPT AS SHOWN.

Amphenol
FCi

© 2016 AFCI

spec ref	-	dr	Qin De-Feng	2012/11/21	projection	MM	size	A2	scale	2.500	
tolerance std	ISO 406 ISO 1101	eng	Jerry Zhang	2018/01/15			ecn no	ELX-DG-28824-1			
TOLERANCES UNLESS OTHERWISE SPECIFIED		chr	Stone Li	2018/01/15			rel level	Released			
surface	ISO 1302	appr	Heaven Cen	2018/01/18	product family	MINI-SAS HD		rel level	Released		
					Amphenol FCi	title	1X2 EXTERNAL ASSEMBLY WITH LIGHT PIPE		dwg no	10120959	
					www.fci.com	cat. no.	-	Product - Customer Drw	sheet 3 of 7	rev	B

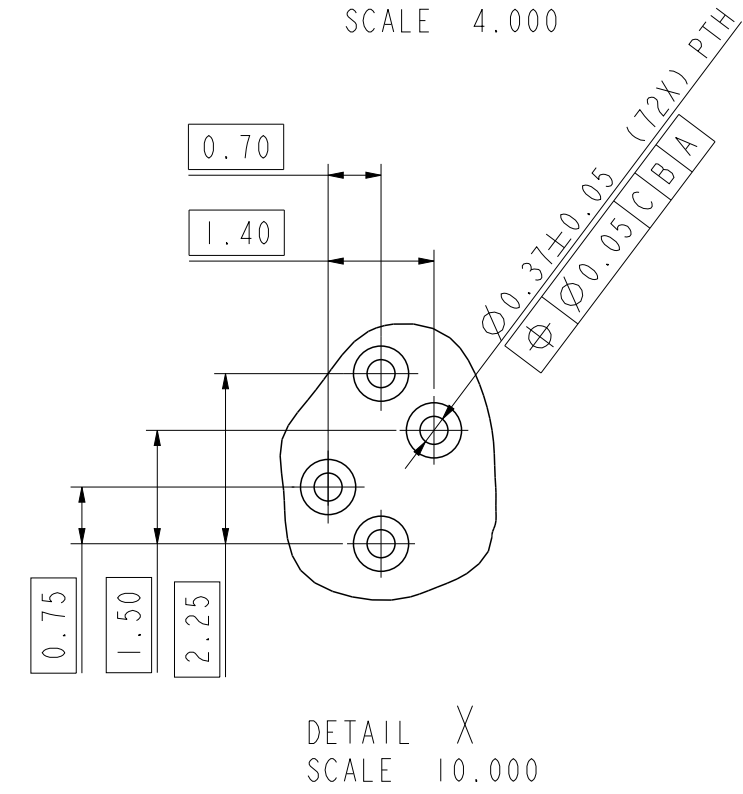
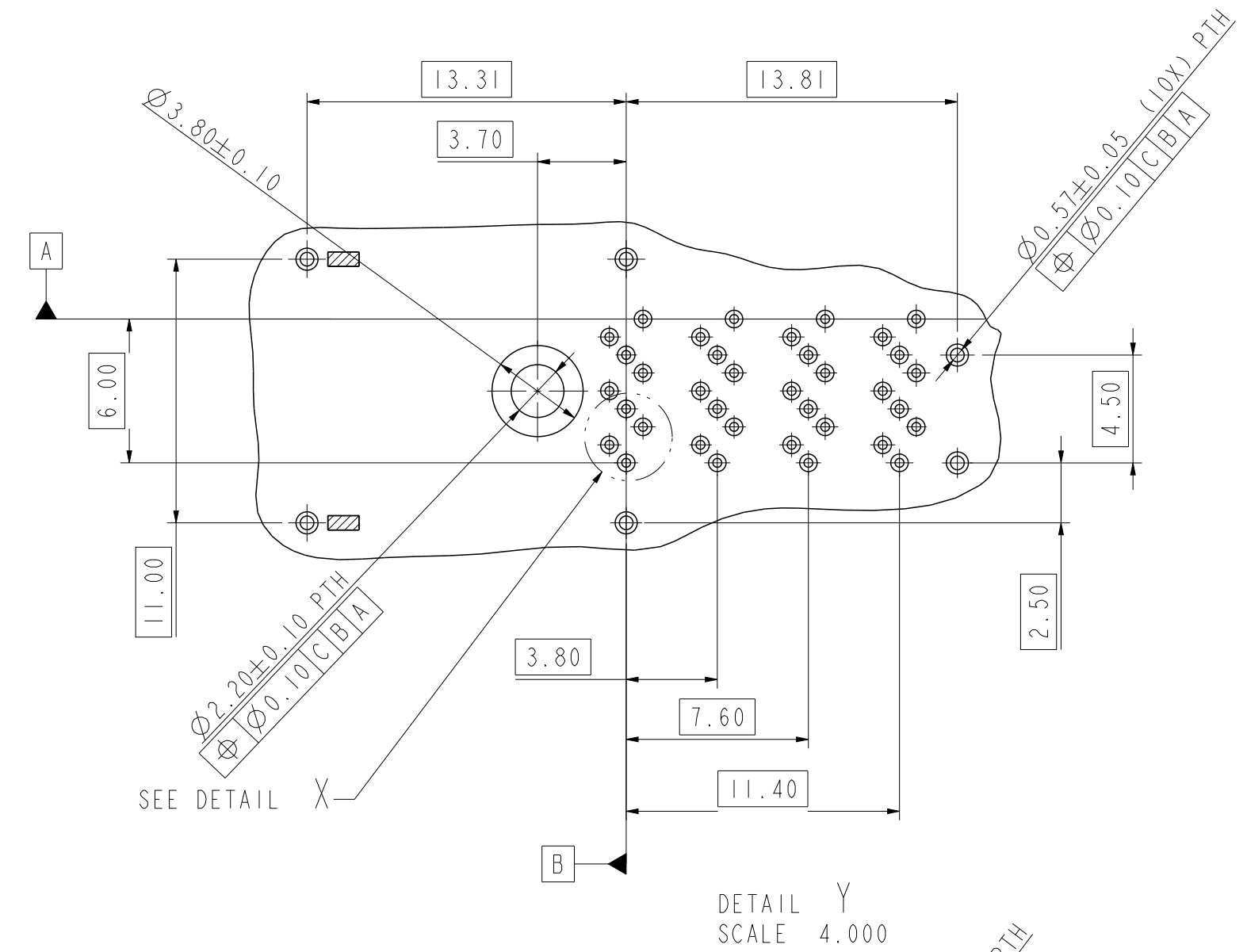
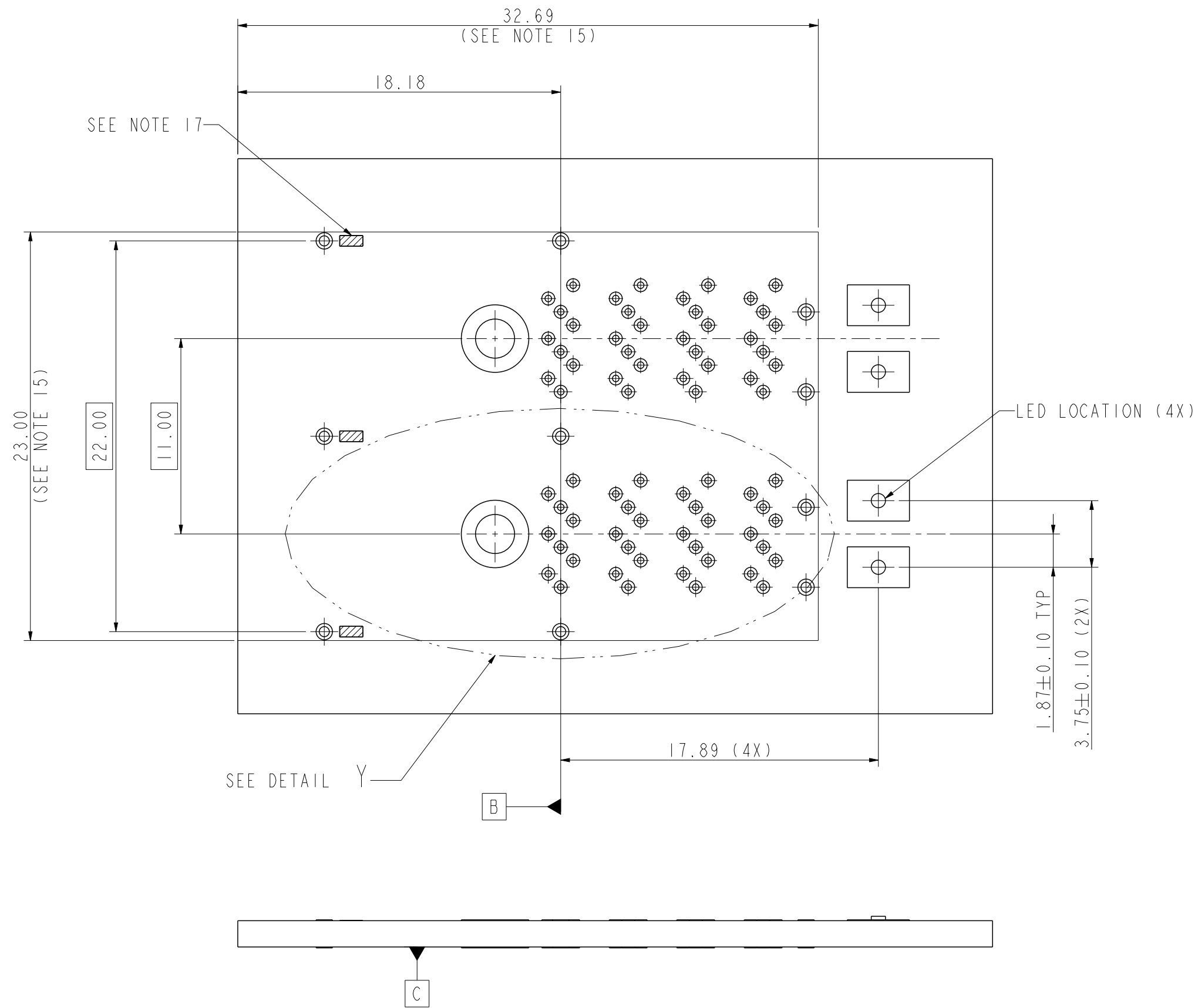

RECOMMENDED BOARD LAYOUT
SEE SFF-8644 FOR DETAIL

NOTES:

10. RECOMMENDED DRILL SIZE FOR $\varnothing 0.37$ FINISHED PTH IS $\varnothing 0.457$.
11. RECOMMENDED ANNULAR RING AROUND $\varnothing 0.37$ FINISHED PTH IS $\varnothing 0.73$.
12. RECOMMENDED DRILL SIZE FOR $\varnothing 0.57$ FINISHED PTH IS $\varnothing 0.68$.
13. RECOMMENDED ANNULAR RING AROUND $\varnothing 0.57$ FINISHED PTH IS $\varnothing 0.93$.
14. MINIMUM RECOMMENDED CENTER TO CENTER SPACING BETWEEN ADJACENT CONNECTORS: 47.00mm.
15. CONNECTOR KEEP OUT AREA.
16. MINIMUM PCB THICKNESS: 1.57mm.
17. CAGE STAND OFF AREA, NO TRACES ON SURFACE OF PCB IN THE AREAS.

spec ref	-	dr	Qin De-Feng	2012/11/21	projection	MM	size	A2	scale	4.000									
tolerance std	ISO 406 ISO 1101	eng	Jerry Zhang	2018/01/15			ecn no	ELX-DG-28824-1	rel level	Released									
TOLERANCES UNLESS OTHERWISE SPECIFIED		chr	Stone Li	2018/01/15															
surface	-	appr	Heaven Cen	2018/01/18	product family	MINI-SAS HD	dwg no	10120959	rev	B									
ISO 1302	<table border="1"> <tr> <td>linear</td> <td>0.X</td> <td>±0.5</td> </tr> <tr> <td></td> <td>0.XX</td> <td>±0.3</td> </tr> <tr> <td></td> <td>0.XXX</td> <td>±-</td> </tr> <tr> <td>angular</td> <td>0°</td> <td>±3°</td> </tr> </table>	linear	0.X	±0.5		0.XX	±0.3		0.XXX	±-	angular	0°	±3°			Amphenol FCI MINI-SAS HD www.fci.com	cat. no.	Product - Customer Drw	sheet 4 of 7
linear	0.X	±0.5																	
	0.XX	±0.3																	
	0.XXX	±-																	
angular	0°	±3°																	

RECOMMENDED KEEP OUT AREAS

RECOMMENDED INSERTION TOOL
KEEP OUT AREA
NO COMPONENTS IN THIS AREA
MORE THAN 7.50mm TALL

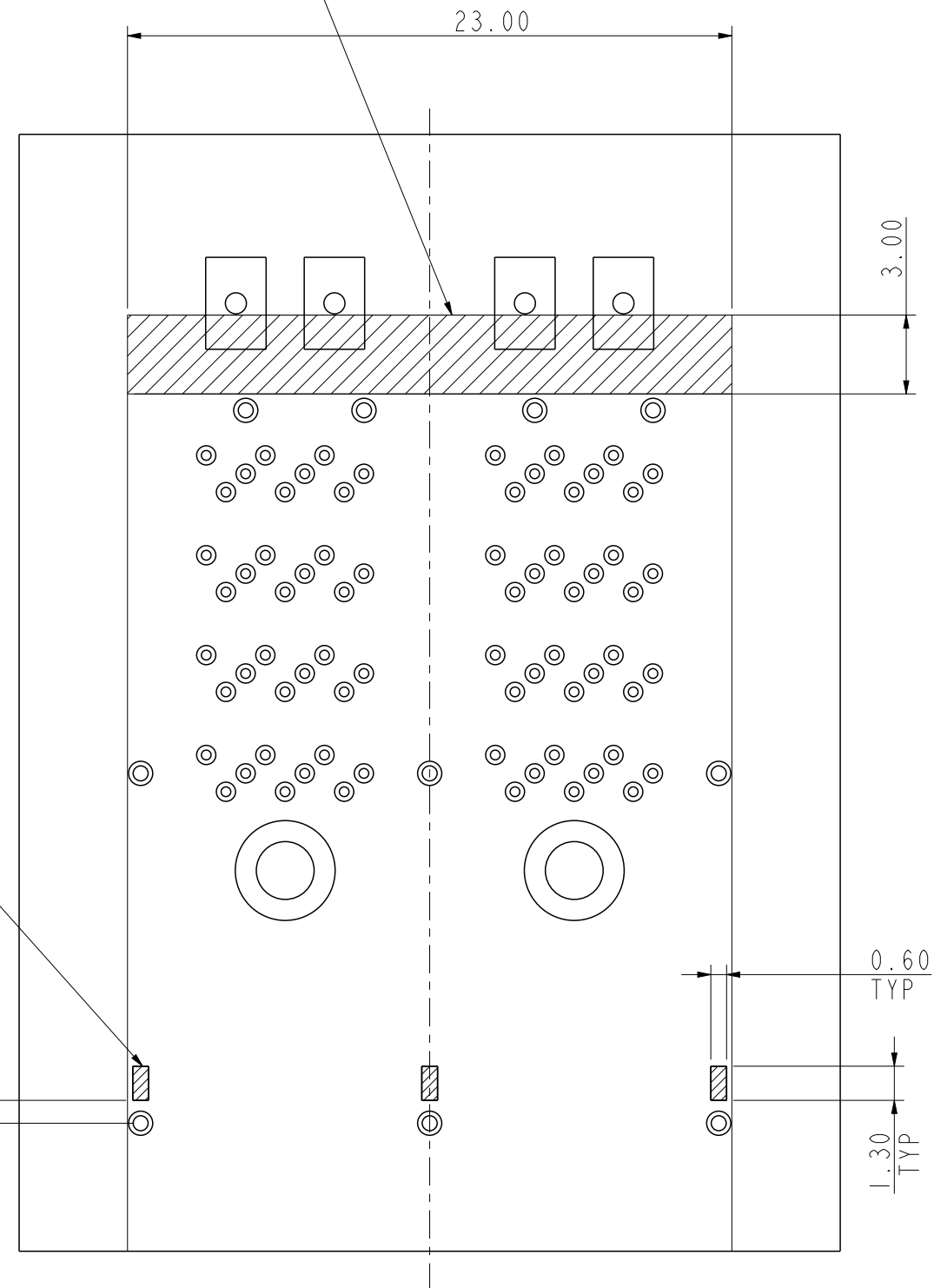

RECOMMENDED EXTRACTION TOOL
KEEP OUT AREA
NO COMPONENTS IN THESE AREAS

RECOMMENDED EXTRACTION TOOL
KEEP OUT AREA
NO COMPONENTS IN THESE AREAS

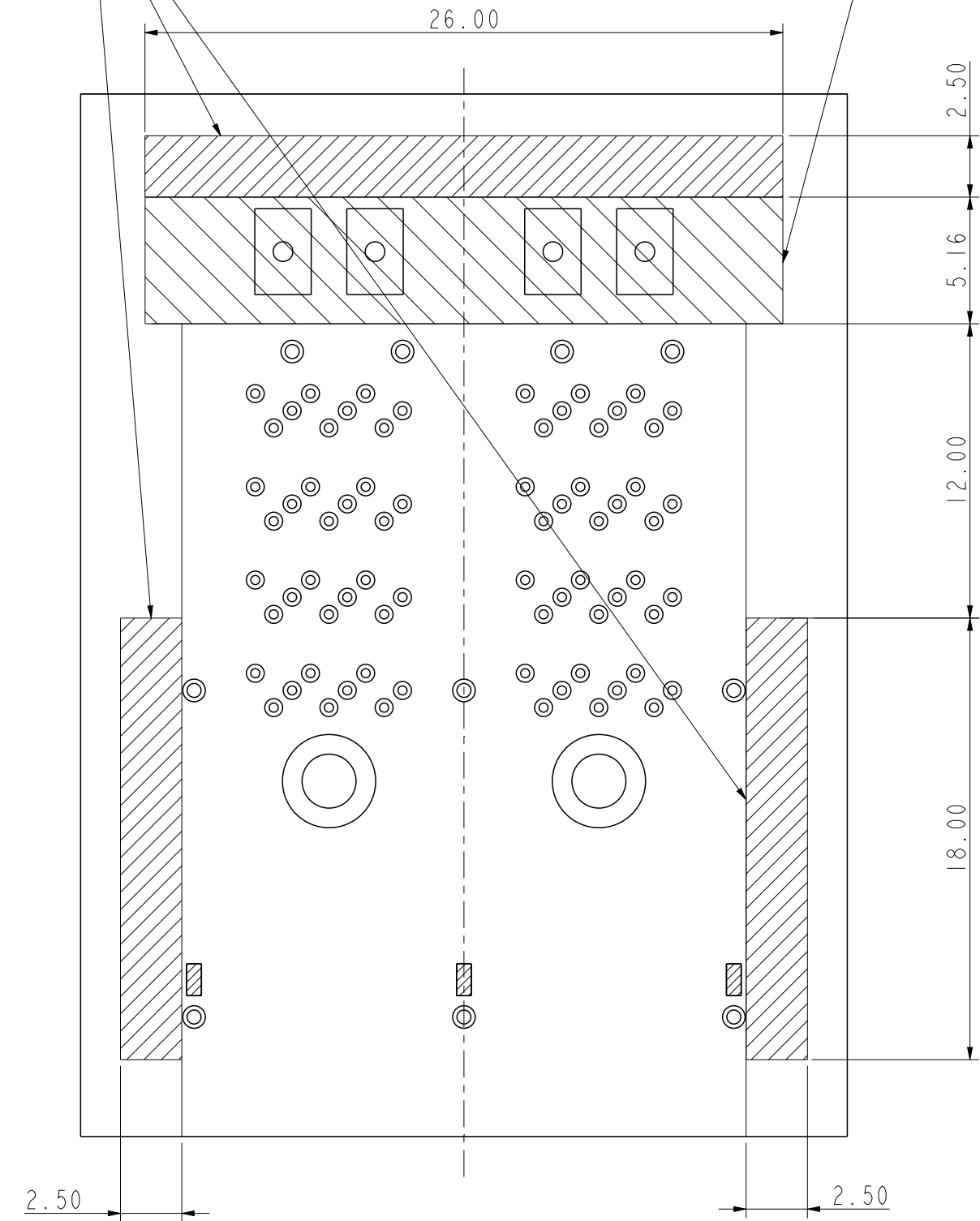

CAGE STAND OFF KEEP OUT AREA

Amphenol
FCi

spec ref	-	dr	Qin De-Feng	2012/11/21	projection	MM	size	A2	scale	4.000
tolerance std	ISO 406 ISO 1101	eng	Jerry Zhang	2018/01/15			ecn no	ELX-DG-28824-1		
TOLERANCES UNLESS OTHERWISE SPECIFIED		chr	Stone Li	2018/01/15			rel level	Released		
surface	ISO 1302	appr	Heaven Cen	2018/01/18			product family	MINI-SAS HD	dwg no	10120959
					www.fci.com	cat. no.	-	Product - Customer Drw	sheet 5 of 7	

PDS: Rev :B

STATUS:Released

Printed: Jan 18, 2018

PIN OUT DESIGNATIONS

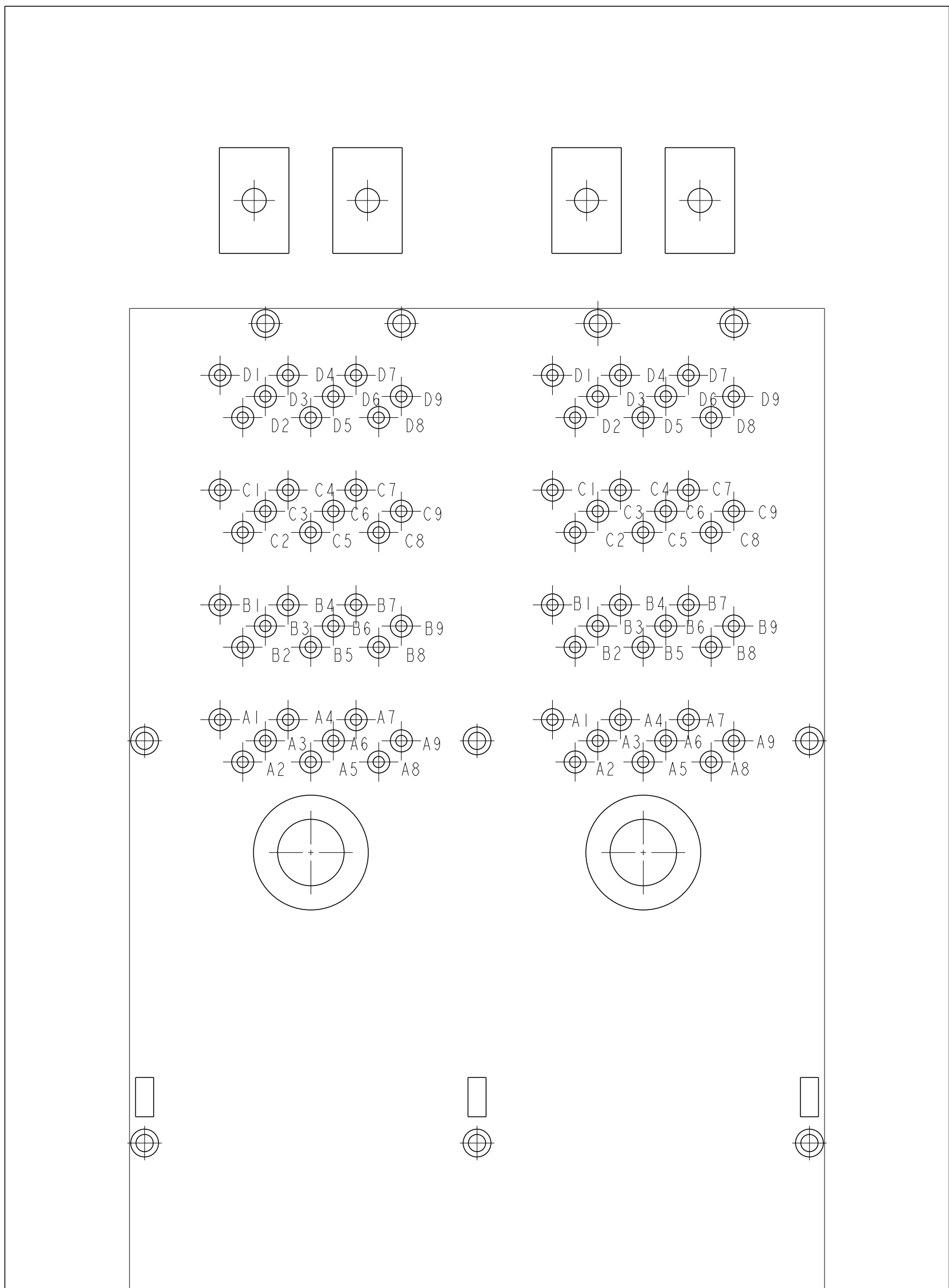

Amphenol
FCi

© 2016 AFCi

spec ref	-	dr	Qin De-Feng	2012/11/21	projection	MM	size	A2	scale	7.000
tolerance std	ISO 406 ISO 1101	eng	Jerry Zhang	2018/01/15			ecn no	ELX-DG-28824-1	rel level	Released
TOLERANCES UNLESS OTHERWISE SPECIFIED		chr	Stone Li	2018/01/15						
surface	ISO 1302	appr	Heaven Cen	2018/01/18	product family	MINI-SAS HD	rel level	Released	title	1X2 EXTERNAL ASSEMBLY WITH LIGHT PIPE MINI-SAS HD
		linear	0.X	±0.5	www.fci.com	cat. no.	-	Product - Customer Drw	divg no	10120959
			0.XX	±0.3				rev		B
		angular	0°	±3°				sheet 6 of 7		

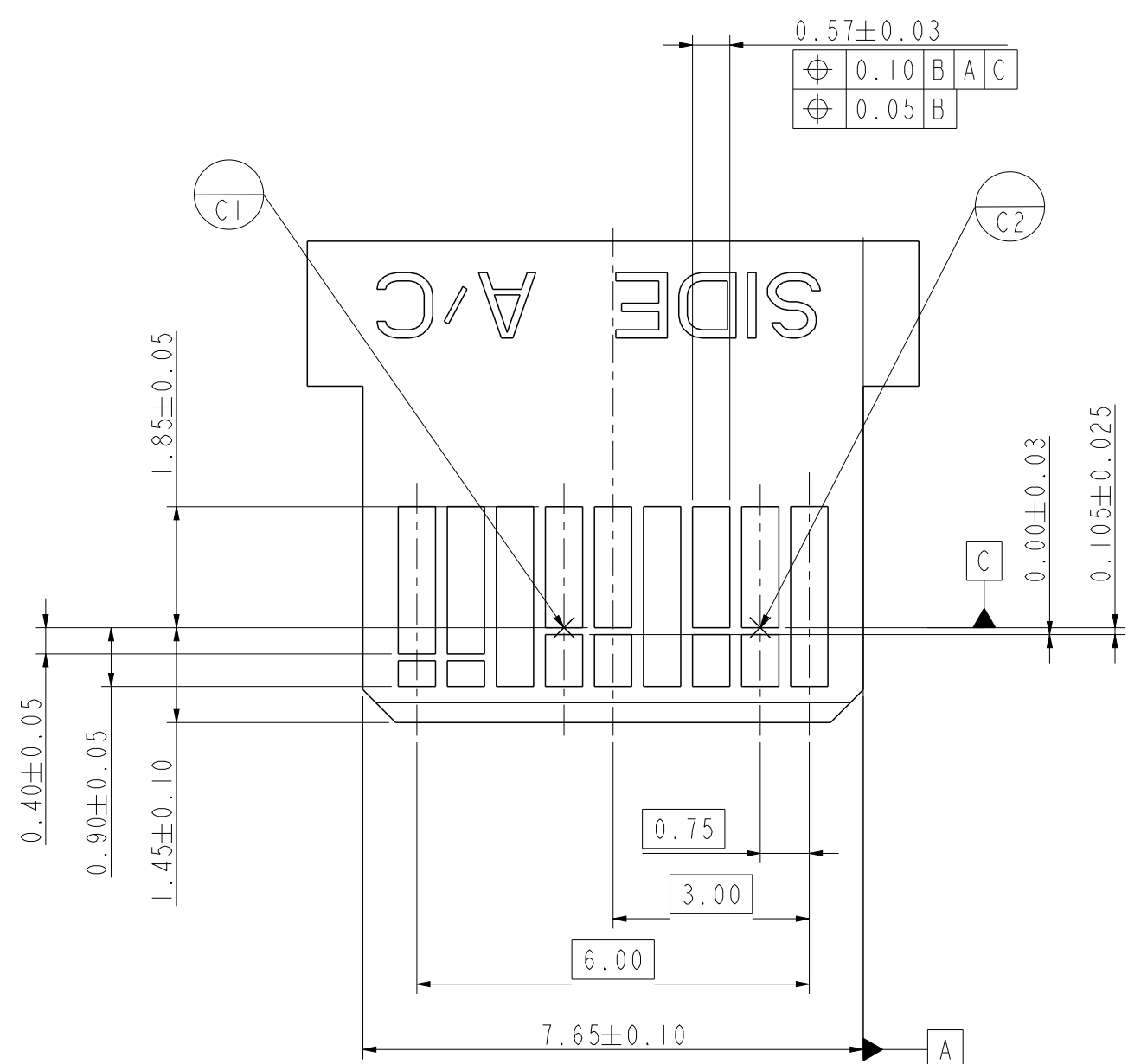
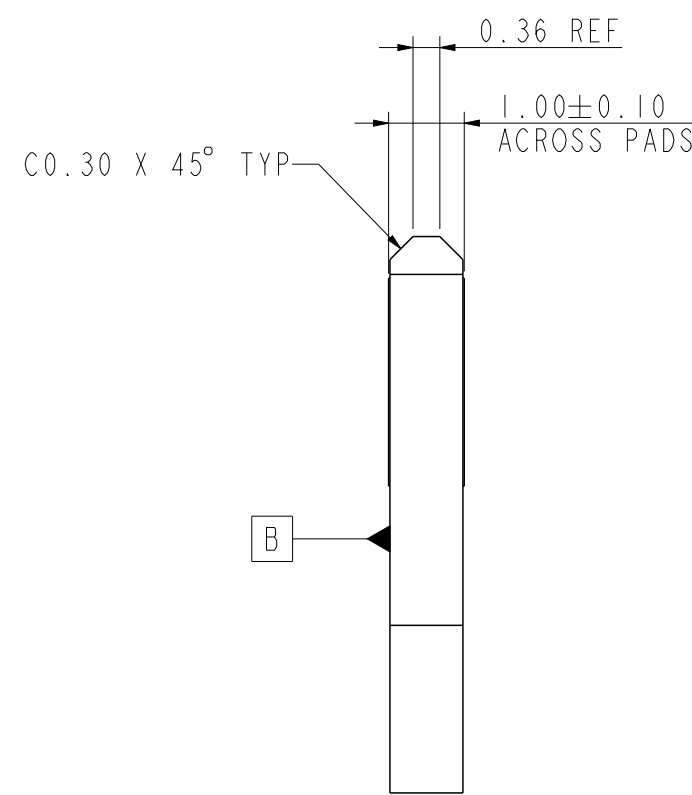
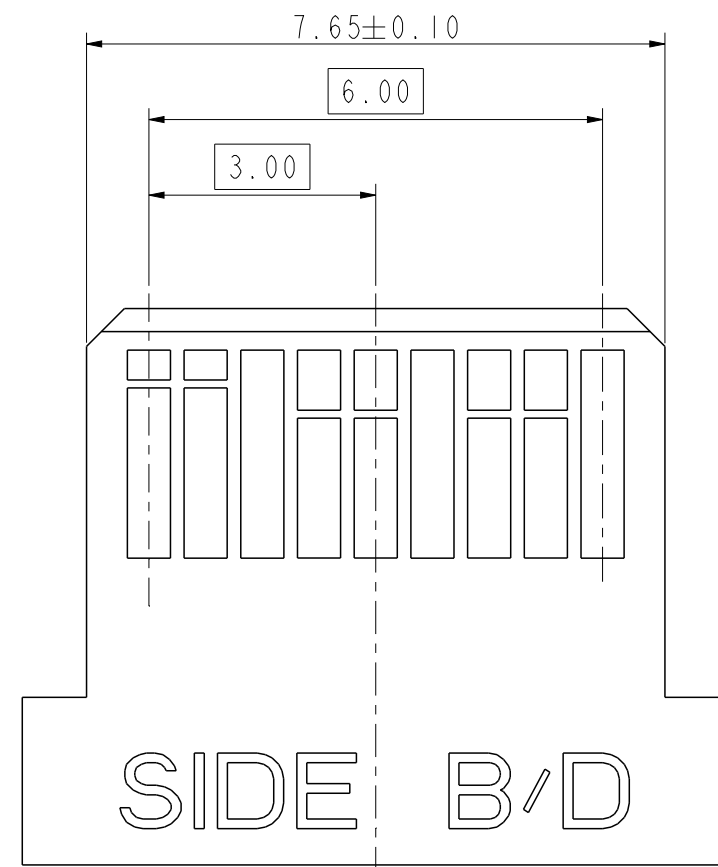

RECOMMENDED PLUG PADDLE CARD
SEE SFF-8644 FOR DETAIL

- NOTES:
- 18. 0.05 MINIMUM KEEP OUT FOR SOLDER MASK AROUND ALL PADS.
 - 19. DATUM C TARGETS ARE DEFINED BY THE RESPECTIVE PAD CENTER LINES AND THE LEADING EDGE OF THE TARGET PADS.

spec ref	-	dr	Qin De-Feng	2012/11/21	projection	MM	size	A2	scale	10.000
tolerance std	ISO 406 ISO 1101	eng	Jerry Zhang	2018/01/15			ecn no	ELX-DG-28824-1		
surface	-	chr	Stone Li	2018/01/15			rel level	Released		
		appr	Heaven Cen	2018/01/18	product family	MINI-SAS HD	rel level	Released		
linear	0.X ±0.5 0.XX ±0.3 0.XXX ±-			title	1X2 EXTERNAL ASSEMBLY WITH LIGHT PIPE			cat. no.	10120959	
angular	0° ±3°	www.fci.com		cat. no.	-			Product - Customer Drw	sheet 7 of 7	