



Chipsmall Limited consists of a professional team with an average of over 10 year of expertise in the distribution of electronic components. Based in Hongkong, we have already established firm and mutual-benefit business relationships with customers from,Europe,America and south Asia,supplying obsolete and hard-to-find components to meet their specific needs.

With the principle of “Quality Parts,Customers Priority,Honest Operation,and Considerate Service”,our business mainly focus on the distribution of electronic components. Line cards we deal with include Microchip,ALPS,ROHM,Xilinx,Pulse,ON,Everlight and Freescale. Main products comprise IC,Modules,Potentiometer,IC Socket,Relay,Connector.Our parts cover such applications as commercial,industrial, and automotives areas.

We are looking forward to setting up business relationship with you and hope to provide you with the best service and solution. Let us make a better world for our industry!



## Contact us

Tel: +86-755-8981 8866 Fax: +86-755-8427 6832

Email & Skype: info@chipsmall.com Web: www.chipsmall.com

Address: A1208, Overseas Decoration Building, #122 Zhenhua RD., Futian, Shenzhen, China



# 3-Axis Digital Compass IC HMC5883

**Honeywell**

*Advanced Information*

The Honeywell HMC5883 is a surface mount multi-chip module designed for low field magnetic sensing with a digital interface for applications such as low cost compassing and magnetometry. The HMC5883 includes our state of the art, high-resolution HMC118X series magneto-resistive sensors plus Honeywell developed ASIC containing amplification, automatic degaussing strap drivers, offset cancellation, 12-bit ADC that enables 1° to 2° compass heading accuracy. The I<sup>2</sup>C serial bus allows for easy interface. The HMC5883 is a 3.0x3.0x0.9mm surface mount 16-pin leadless chip carrier (LCC). Applications for the HMC5883 include Mobile Phones, Netbooks, Consumer Electronics, Auto Navigation Systems, and Personal Navigation Devices.

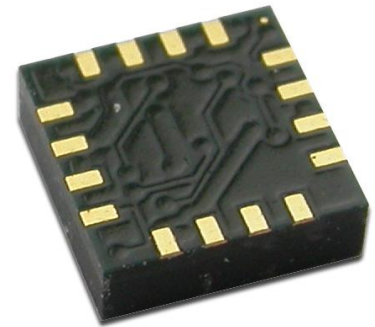

The HMC5883 utilizes Honeywell's Anisotropic Magneto-resistive (AMR) technology that provides advantages over other magnetic sensor technologies. These anisotropic, directional sensors feature precision in-axis sensitivity and linearity, solid-state construction with very low cross-axis sensitivity designed to measure both direction and magnitude of Earth's magnetic fields, from milli-gauss to 8 gauss. Honeywell's Magnetic Sensors are among the most sensitive and reliable low-field sensors in the industry.

## FEATURES

- ▶ 3-Axis Magneto-resistive Sensors and ASIC in a 3.0x3.0x0.9mm LCC Surface Mount Package
- ▶ 12-Bit ADC Coupled with Low Noise AMR Sensors Achieves 5 milli-Gauss Resolution in ±8 Gauss Fields
- ▶ Built-In Self Test
- ▶ Low Voltage Operations (1.6 to 3.3V)
- ▶ Built-In Strap Drive Circuits
- ▶ I<sup>2</sup>C Digital Interface
- ▶ Lead Free Package Construction
- ▶ Wide Magnetic Field Range (+/-8 Oe)
- ▶ Software and Algorithm Support Available
- ▶ Fast 116 Hz Maximum Output Rate

## BENEFITS

- ▶ Small Size for Highly Integrated Products. Just Add a Micro-Controller Interface, Plus Two External SMT Capacitors Designed for High Volume, Cost Sensitive OEM Designs Easy to Assemble & Compatible with High Speed SMT Assembly
- ▶ Enables 1° to 2° Degree Compass Heading Accuracy
- ▶ Enables Low-Cost Functionality Test after Assembly in Production
- ▶ Compatible for Battery Powered Applications
- ▶ Set/Reset and Offset Strap Drivers for Degaussing, Self Test, and Offset Compensation
- ▶ Popular Two-Wire Serial Data Interface for Consumer Electronics
- ▶ RoHS Compliance
- ▶ Sensors Can Be Used in Strong Magnetic Field Environments with a 1° to 2° Degree Compass Heading Accuracy
- ▶ Compassing Heading, Hard Iron, Soft Iron, and Auto Calibration Libraries Available
- ▶ Enables Pedestrian Navigation and LBS Applications

# HMC5883

## SPECIFICATIONS (\* Tested at 25°C except stated otherwise.)

Characteristics	Conditions*	Min	Typ	Max	Units
-----------------	-------------	-----	-----	-----	-------

### Power Supply

Supply Voltage	AVDD Referenced to AGND	2.5		3.3	Volts
	DVDD Referenced to DGND	1.6	1.8	2.0	Volts
Current Draw	Sleep Mode (dual supply)	-	2.5	-	µA
	Idle Mode (dual supply)	-	240	-	µA
	Measurement Mode (8Hz averaged)	-	640	-	µA
	Dual supply (AVDD = 2.5V, DVDD = 1.8V)				
	Sleep Mode (single supply)	-	110	-	µA
	Idle Mode (single supply)	-	340	-	µA
	Measurement Mode (8Hz averaged)	-	740	-	µA
	Single supply (AVDD = 2.5V)				

### Performance

Field Range	Full scale (FS) – total applied field (Typical)	-8		+8	gauss
Mag Dynamic Range	3-bit gain control	±1		±8	gauss
Resolution	AVDD=3.0V, GN2		10		milli-gauss
Linearity	±2.0 gauss input range			0.1	±% FS
Hysteresis	±2.0 gauss input range		±25		ppm
Cross-Axis Sensitivity	Test Conditions: Cross field = 0.5 gauss, Happlied = ±3 gauss		±0.2%		%FS/gauss
Disturbing Field	Sensitivity starts to degrade. Use S/R pulse to restore sensitivity.			20	gauss
Output Rate	Refer to Configuration Register A section		15	116	Hz
Measurement Period	From receiving command to data ready		8.3		msec
Turn-on Time			200		µs
Gain Tolerance	All gain/dynamic range settings		±5		%
I <sup>2</sup> C Address	7-bit address		0x1E		hex
	8-bit read address		0x3D		hex
	8-bit write address		0x3C		hex
I <sup>2</sup> C Rate	Controlled by I <sup>2</sup> C Master			400	kHz
I <sup>2</sup> C Hysteresis	Hysteresis of Schmitt trigger inputs on SCL and SDA - Fall (DVDD=1.8V) Rise (DVDD=1.8V)		0.603		Volts
			1.108		Volts
Self Test	X & Y Axes		±0.64		gauss
	Z Axis		±0.59		gauss

### General

ESD Voltage	Human Body Model (all pins)			700	Volts
	Machine Model (all pins)			170	Volts
Operating Temperature	Ambient	-30		85	°C
Storage Temperature	Ambient, unbiased	-40		125	°C
Reflow Classification	MSL 3, 260 °C Peak Temperature				
Package Size	Length and Width	2.85	3.00	3.15	mm
Package Height			0.9	1.0	mm

# HMC5883

## Absolute Maximum Ratings (\* Tested at 25°C except stated otherwise.)

Characteristics	Min	Max	Units
Supply Voltage AVDD	-0.3	5	Volts
Supply Voltage DVDD	-0.3	2	Volts

## PIN CONFIGURATIONS

(Arrow indicates direction of applied field that generates a positive output voltage after a SET pulse.)

Pin	Name	Description
1	SCL	Serial Clock – I2C Master/Slave Clock
2	AVDD	Analog Positive Supply
3	NC	Not to be Connected
4	NC	No Connection
5	NC	No Connection
6	NC	No Connection
7	NC	No Connection
8	SETP	Set/Reset Strap Positive – S/R Capacitor (C2) Connection
9	GND	Supply Ground/Return
10	C1	Reservoir Capacitor (C1) Connection
11	GND	Supply Ground/Return
12	SETC	S/R Capacitor (C2) Connection
13	DVDD	Digital Positive Supply
14	VREN	Voltage Regulator Enable, (GND = Dual Supply, AVDD = Single Supply)
15	DRDY	Data Ready, Interrupt Pin. Nominally high. Low for 5usec when data is placed in the output registers
16	SDA	Serial Data – I2C Master/Slave Data

Table 1: Pin Configurations



# HMC5883

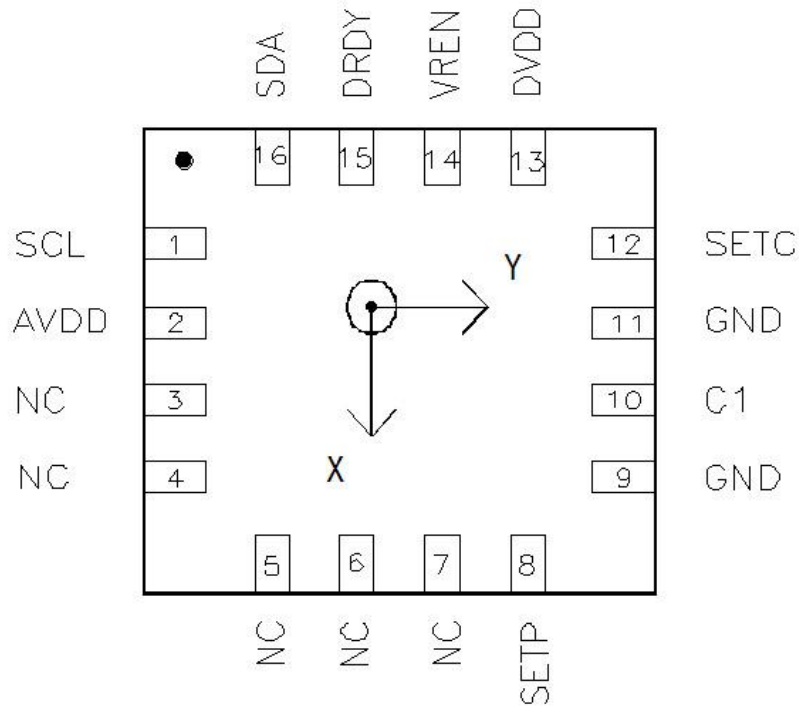

TOP VIEW (looking through)

## PACKAGE OUTLINES

### PACKAGE DRAWING HMC5883 (16-PIN LPCC, dimensions in millimeters)

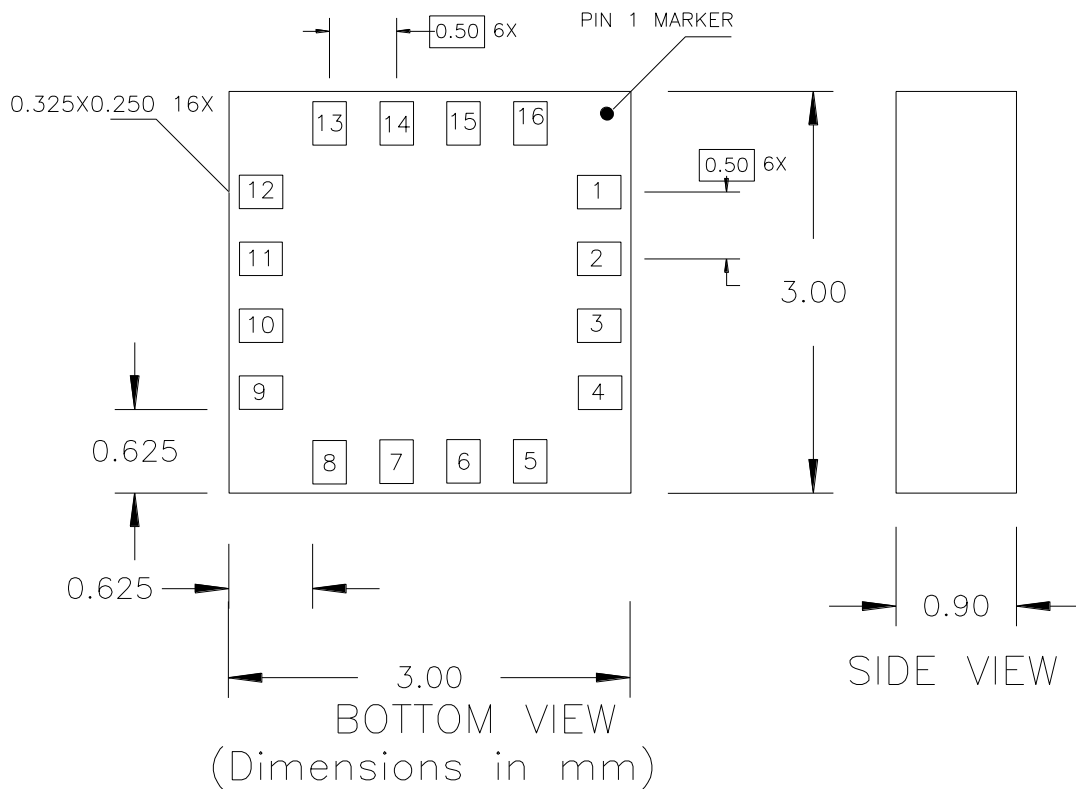

# HMC5883

## MOUNTING CONSIDERATIONS

The following is the recommend printed circuit board (PCB) footprint for the HMC5883.

### PCB Pad Definition and Traces

The HMC5883 is a fine pitch LCC package with a 0.50mm pin pitch (spacing), with the pin pads defined as 0.325mm by 0.25mm in size. PCB pads are recommended to be oversized by 0.025mm from each pad for a short dimension oversize of 0.05mm. The interior PCB pad is recommended to be 0.05mm oversized per pin with an exterior oversize of 0.20mm for proper package centering and to permit test probing. Size the traces between the HMC5883 and the external capacitors (C1 and C2) to handle the 1 ampere peak current pulses with low voltage drop on the traces.

### Stencil Design and Solder Paste

A 4 mil stencil and 100% paste coverage is recommended for the electrical contact pads.

### Pick and Place

Placement is machine dependant and no restrictions are recommended, and have been tested with mechanical centering. Placement force should be equivalent 1206 SMT resistors and enough force should be used to squeeze the paste out from the package/contact pad overlap and to keep the package pin contacts vertical.

### Reflow Assembly

This device is classified as MSL 3 with 260 °C peak reflow temperature. A baking process (125 °C, 24 hrs) is required if device is not kept continuously in a dry (< 10% RH) environment before assembly. No special reflow profile is required for the HMC5883 which is compatible with lead eutectic and lead-free solder paste reflow profiles. Honeywell recommends the adherence to solder paste manufacturer's guidelines.

## INTERNAL SCHEMATIC DIAGRAM

### HMC5883

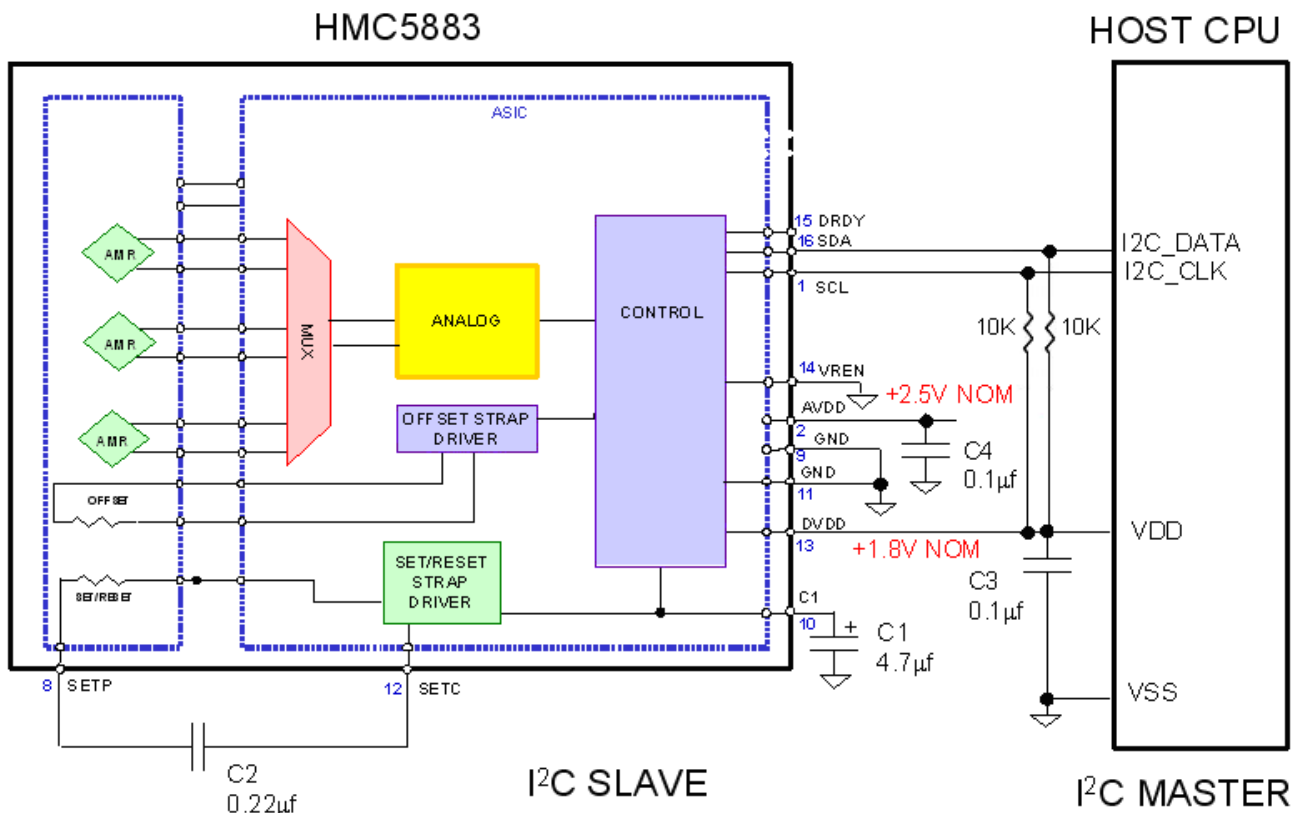

# HMC5883

## DUAL SUPPLY REFERENCE DESIGN

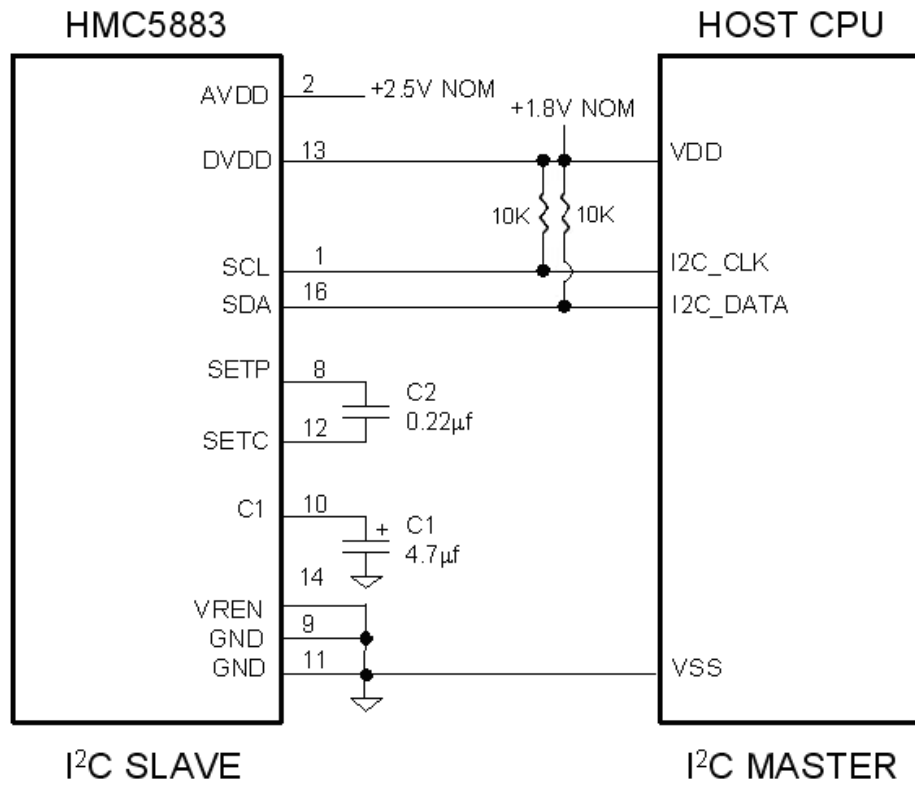

## SINGLE SUPPLY REFERENCE DESIGN

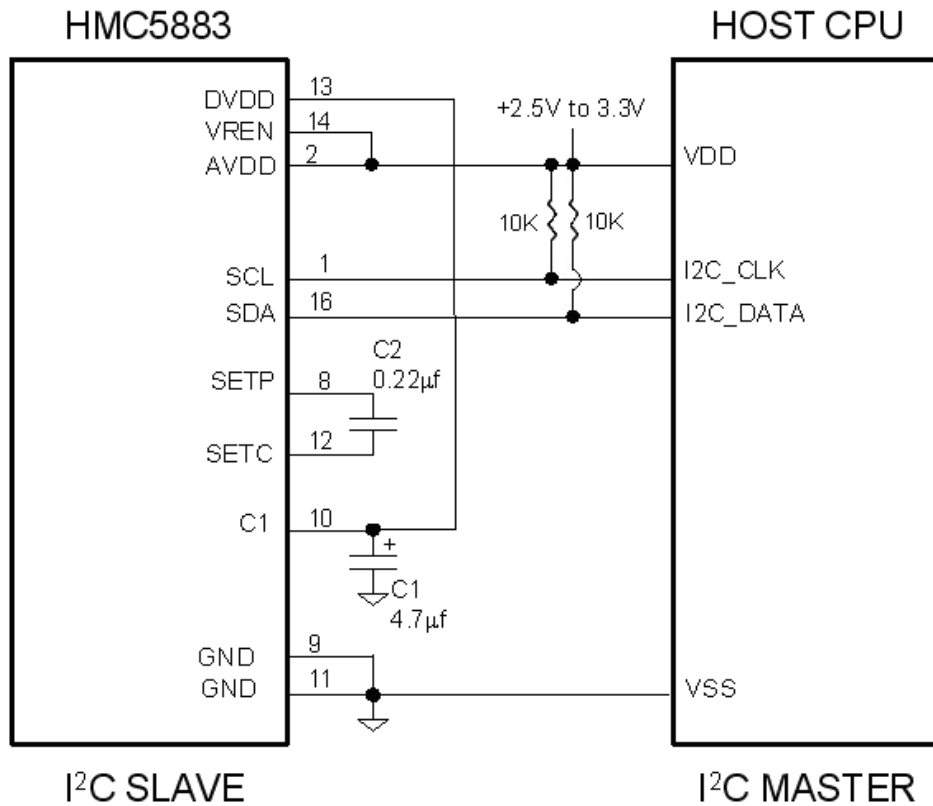

# HMC5883

## PERFORMANCE

The following graphs highlight HMC5883's performance.

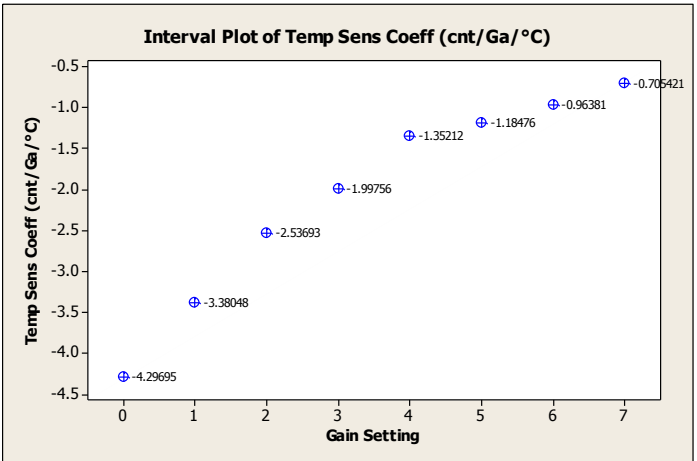
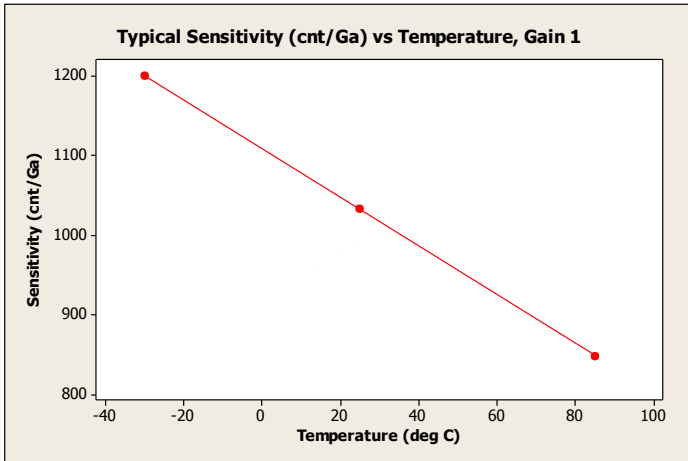
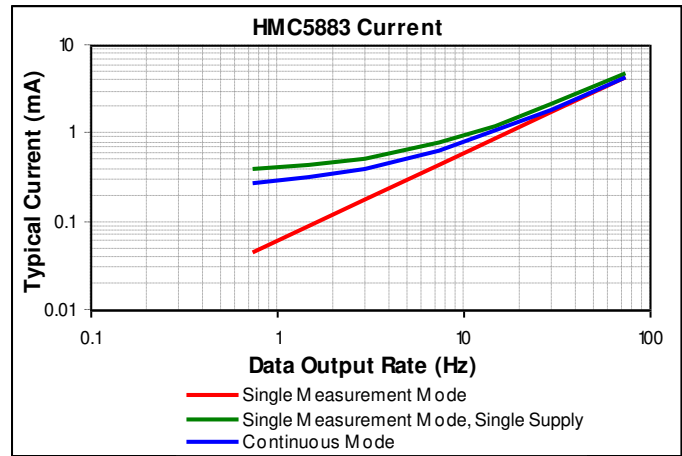
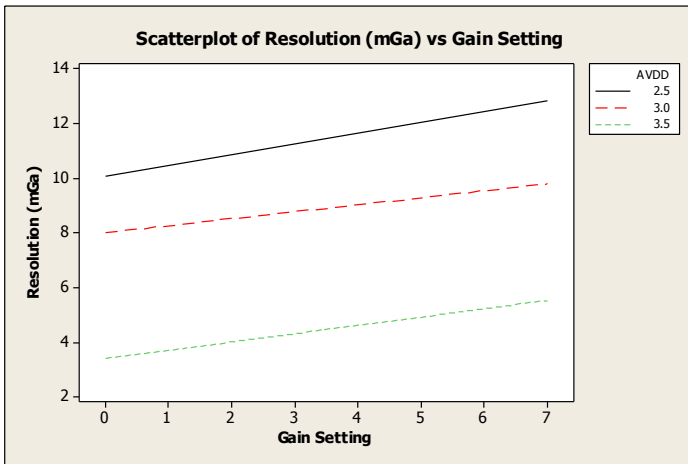

### Typical Measurement Period in Single-Measurement Mode

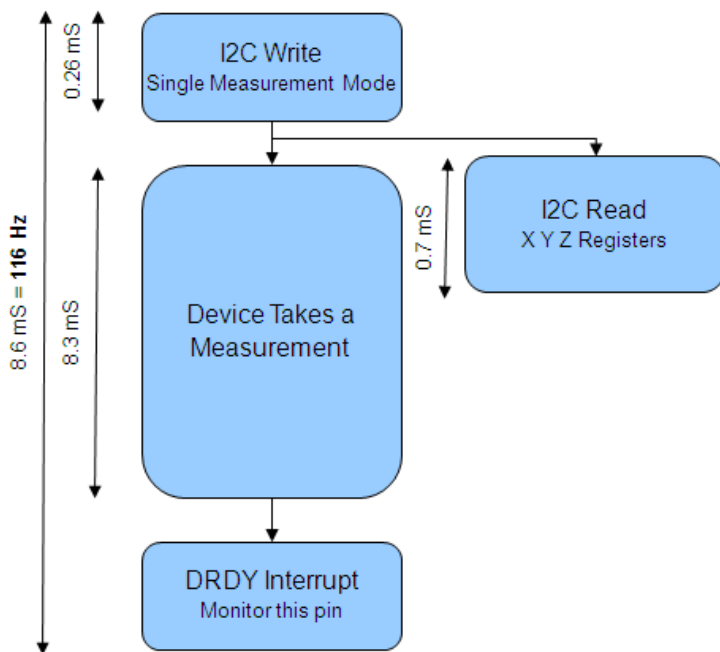



# HMC5883

## BASIC DEVICE OPERATION

### Anisotropic Magneto-Resistive Sensors

The Honeywell HMC5883 magnetoresistive sensor circuit is a trio of sensors and application specific support circuits to measure magnetic fields. With power supply applied, the sensor converts any incident magnetic field in the sensitive axis directions to a differential voltage output. The magnetoresistive sensors are made of a nickel-iron (Permalloy) thin-film and patterned as a resistive strip element. In the presence of a magnetic field, a change in the bridge resistive elements causes a corresponding change in voltage across the bridge outputs.

These resistive elements are aligned together to have a common sensitive axis (indicated by arrows on the pinouts) that will provide positive voltage change with magnetic fields increasing in the sensitive direction. Because the output only is in proportion to the one-dimensional axis (the principle of anisotropy) and its magnitude, additional sensor bridges placed at orthogonal directions permit accurate measurement of arbitrary field direction.

### Self Test

To check the HMC5883 for proper operation, a self test feature is incorporated in which the sensor is internally excited with a nominal magnetic field (in either positive or negative bias configuration). This field is then measured and reported. See SELF TEST OPERATION section below.

### Power Management

This device is capable of operating with a single supply (AVDD) or dual supplies (AVDD and DVDD). Pin VREN makes this selection by enabling the internal digital supply voltage regulator. When VREN is tied to AVDD, the device is in single supply operation; this device is powered from AVDD; and the internal voltage regulator is enabled. When VREN is tied to AGND this device operates with both AVDD and DVDD as supplies. The table below shows the modes available at the various power supply conditions.

DVDD	AVDD	Pin VREN	Modes Supported	Description
High	High	AGND	All	Internal voltage regulator: Disabled. Digital I/O pins: Range from DGND to DVDD. Device fully functional. Digital logic blocks are powered from DVDD supply, including all on-board clocks.
High	Low	AGND	Idle, Sleep	Internal voltage regulator: Disabled. Digital I/O pins: Range from DGND to DVDD. Device Measurement functionality not supported. Device I <sup>2</sup> C bus and register access supported.
Internally regulated	High	AVDD	All	Internal voltage regulator: Enabled Digital I/O pins: Range from AGND to AVDD Device fully functional. Digital logic blocks are powered through on-board regulator.

Table 2: Operational Modes and Supply States

### Voltage Regulator

This ASIC has an internal voltage regulator which, depending on the application needs, may be used instead of supplying voltage to pin DVDD. If DVDD pin is used, the internal voltage regulator is not engaged. When both supplies are used, DVDD is typically high before AVDD, but no latch-up conditions will exist if DVDD is brought high after AVDD.

# HMC5883

## Power on Reset

Power on reset (POR) circuit shall return the device to the power-on default state. All registers shall be returned to their default values. Circuitry shall return to its default state, such as, but not limited to: MUX channel, ADC state machine, and bias current.

## I<sup>2</sup>C Interface

Control of this device is carried out via the I<sup>2</sup>C bus. This device will be connected to this bus as a slave device under the control of a master device, such as the processor.

This device shall be compliant with *I<sup>2</sup>C-Bus Specification*, document number: 9398 393 40011. As an I<sup>2</sup>C compatible device, this device has a 7-bit serial address and supports I<sup>2</sup>C protocols. This device shall support standard and fast modes, 100kHz and 400kHz respectively, but cannot support the high speed mode (Hs). External pull-up resistors are required to support these standard and fast speed modes. Depending on the application, the internal pull-ups may be used to support slower data speeds than specified by I<sup>2</sup>C standards. This device does not contain 50nsec spike suppression as required by fast mode operation in the I<sup>2</sup>C-Bus Specification, "Table 4 Characteristics of the SDA and SCL I/O stages for F/S-mode I<sup>2</sup>C-bus devices".

Activities required by the master (register read and write) have priority over internal activities, such as the measurement. The purpose of this priority is to not keep the master waiting and the I<sup>2</sup>C bus engaged for longer than necessary.

## I<sup>2</sup>C Pull-up Resistors

Pull-up resistors are placed on the two I<sup>2</sup>C bus lines. Typically these resistors are off-chip, but, to conserve board space in specific low clock speed applications, they are internal to this device.

## Internal Clock

The device has an internal clock for internal digital logic functions and timing management.

## H-Bridge for Set/Reset Strap Drive

The ASIC contains large switching FETs capable of delivering a large but brief pulse to the Set / Reset strap of the sensor. This strap is largely a resistive load.

## Charge Current Limit

The current that reservoir capacitor (C1) can draw when charging is limited. When using dual supplies this device shall limit the current drawn from DVDD source to charge this capacitor. When only a single supply is used, Pin DVDD is externally tied to pin C1. In this configuration, current is still limited. For example, the internal voltage regulator will limit this current draw.

## Bias Current Generator

The bias current generator is used to apply a bias current to the offset strap of the magneto-resistive sensor, which creates an artificial magnetic field bias on the sensor. This function is enabled and the polarity is set by bits MS[n] in the configuration register. The bias current generator generates dc current (about 5.5mA) supplied from the AVDD supply.

# HMC5883

## MODES OF OPERATION

This device has several operating modes whose primary purpose is power management. This section describes these modes.

### Continuous-Measurement Mode

During continuous-measurement mode, the device continuously makes measurements and places measured data in data output registers. Settings in the configuration register affect the data output rate (bits DO[n]), the measurement configuration (bits MS[n]), and the gain (bits GN[n]) when in continuous-measurement mode. To conserve current between measurements, the device is placed in a state similar to idle mode, but the mode is not changed to idle mode. That is, MD[n] bits are unchanged. Data can be re-read from the data output registers if necessary; however, if the master does not ensure that the data register is accessed before the completion of the next measurement, the new measurement may be lost. All registers maintain values while in continuous-measurement mode. The I<sup>2</sup>C bus is enabled for use by other devices on the network in while continuous-measurement mode.

### Single-Measurement Mode

This is the default single supply power-up mode. In dual supply configuration this is the default mode when AVDD goes high. During single-measurement mode, the device makes a single measurement and places the measured data in data output registers. Settings in the configuration register affect the measurement configuration (bits MS[n]), and the gain (bits GN[n]) when in single-measurement mode. After the measurement is complete and output data registers are updated, the device is placed sleep mode, and the mode register *is* changed to sleep mode by setting MD[n] bits. All registers maintain values while in single-measurement mode. The I<sup>2</sup>C bus is enabled for use by other devices on the network while in single-measurement mode.

### Idle Mode

During this mode the device is accessible through the I<sup>2</sup>C bus, but major sources of power consumption are disabled, such as, but not limited to, the ADC, the amplifier, the SVDD pin, and the sensor bias current. All registers maintain values while in idle mode. The I<sup>2</sup>C bus is enabled for use by other devices on the network while in idle mode.

### Sleep Mode

This is the default dual supply power-up mode when only DVDD goes high and AVDD remains low. During sleep mode the device functionality is limited to listening to the I<sup>2</sup>C bus. The internal clock is not running and register values are not maintained while in sleep mode. The only functionality that exists during this mode is the device is able to recognize and execute any instructions specific to this device but does not change from sleep mode due to other traffic on the I<sup>2</sup>C bus. The I<sup>2</sup>C bus is enabled for use by other devices on the network while in sleep mode. This mode has two practical differences from idle mode. First this state will create less noise on system since the clock is disabled, and secondly this state is a lower current consuming state since the clock is disabled.

### Off Mode

During off mode device is off. No device functionality exists. Both AVDD and DVDD are low. The I<sup>2</sup>C bus is enabled for use by other devices on the network in off mode. In this mode the I<sup>2</sup>C pins shall be in a high impedance state.

# HMC5883

## REGISTERS

This device is controlled and configured via a number of on-chip registers, which are described in this section. In the following descriptions, *set* implies a logic 1, and *reset* or *clear* implies a logic 0, unless stated otherwise.

### Register List

The table below lists the registers and their access. All address locations are 8 bits.

Address Location	Name	Access
00	Configuration Register A	Read/Write
01	Configuration Register B	Read/Write
02	Mode Register	Read/Write
03	Data Output X MSB Register	Read
04	Data Output X LSB Register	Read
05	Data Output Z MSB Register	Read
06	Data Output Z LSB Register	Read
07	Data Output Y MSB Register	Read
08	Data Output Y LSB Register	Read
09	Status Register	Read
10	Identification Register A	Read
11	Identification Register B	Read
12	Identification Register C	Read

Table 5: Register List

### Register Access

This section describes the process of reading from and writing to this device. The device uses an address pointer to indicate which register location is to be read from or written to. These pointer locations are sent from the master to this slave device and succeed the 7-bit address plus 1 bit read/write identifier.

To minimize the communication between the master and this device, the address pointer updates automatically without master intervention. This automatic address pointer update has two additional features. First when address 12 or higher is accessed the pointer updates to address 00 and secondly when address 09 is reached, the pointer rolls back to address 03. Logically, the address pointer operation functions as shown below.

```
If (address pointer = 09) then address pointer = 03  
Else if (address pointer >= 12) then address pointer = 0  
Else (address pointer) = (address pointer) + 1
```

The address pointer value itself cannot be read via the I<sup>2</sup>C bus.

Any attempt to read an invalid address location returns 0's, and any write to an invalid address location or an undefined bit within a valid address location is ignored by this device.

To move the address pointer to a random register location, first issue a "write" to that register location with no data byte following the command. For example, to move the address pointer to register 10, send 0x3C 0x0A.

# HMC5883

## Configuration Register A

The configuration register is used to configure the device for setting the data output rate and measurement configuration. CRA0 through CRA7 indicate bit locations, with *CRA* denoting the bits that are in the configuration register. CRA7 denotes the first bit of the data stream. The number in parenthesis indicates the default value of that bit.

CRA7	CRA6	CRA5	CRA4	CRA3	CRA2	CRA1	CRA0
(0)	(0)	(0)	DO2 (1)	DO1 (0)	DO0 (0)	MS1 (0)	MS0 (0)

Table 6: Configuration Register A

Location	Name	Description
CRA7 to CRA5	0	These bits must be cleared for correct operation.
CRA4 to CRA2	DO2 to DO0	Data Output Rate Bits. These bits set the rate at which data is written to all three data output registers.
CRA1 to CRA0	MS1 to MS0	Measurement Configuration Bits. These bits define the measurement flow of the device, specifically whether or not to incorporate an applied bias to the sensor into the measurement.

Table 7: Configuration Register A Bit Designations

The Table below shows all selectable output rates. All three channels shall be measured within a given output rate. Other output rates with maximum rate of 116 Hz can be achieved by monitoring DRDY interrupt pin in single measurement mode. DRDY pin is normally high and is low for 5  $\mu$ sec when data is placed in the output registers.

DO2	DO1	DO0	Typical Data Output Rate (Hz)
0	0	0	0.75
0	0	1	1.5
0	1	0	3
0	1	1	7.5
1	0	0	15 (default)
1	0	1	30
1	1	0	75
1	1	1	Not used

Table 8: Data Output Rates

MS1	MS0	Mode
0	0	Normal measurement configuration (default). In normal measurement configuration the device follows normal measurement flow. The positive and negative pins of the resistive load are left floating and high impedance.
0	1	Positive bias configuration for X and Y axes, negative bias configuration for Z axis. In this configuration, a positive current is forced across the resistive load for X and Y axes, a negative current for Z axis.
1	0	Negative bias configuration for X and Y axes, positive bias configuration for Z axis. In this configuration, a negative current is forced across the resistive load for X and Y axes, a positive current for Z axis.
1	1	This configuration is not used.

Table 9: Measurement Modes

# HMC5883

## Configuration Register B

The configuration register B for setting the device gain. CRB0 through CRB7 indicate bit locations, with *CRB* denoting the bits that are in the configuration register. CRB7 denotes the first bit of the data stream. The number in parenthesis indicates the default value of that bit.

CRB7	CRB6	CRB5	CRB4	CRB3	CRB2	CRB1	CRB0
GN2 (0)	GN1 (0)	GN0 (1)	(0)	(0)	(0)	(0)	(0)

Table 10: Configuration B Register

Location	Name	Description
CRB7 to CRB5	GN2 to GN0	Gain Configuration Bits. These bits configure the gain for the device. The gain configuration is common for all channels.
CRB4 to CRB0	0	This bit must be cleared for correct operation.

Table 11: Configuration Register B Bit Designations

The table below shows nominal gain settings.

GN2	GN1	GN0	Sensor Input Field Range:	Gain (counts/Gauss)	Output Range
0	0	0	± 0.9 Ga	1280	0xF800–0x07FF (-2048–2047)
0	0	1	± 1.2 Ga	1024 (default)	0xF800–0x07FF (-2048–2047)
0	1	0	± 1.9 Ga	768	0xF800–0x07FF (-2048–2047)
0	1	1	± 2.5 Ga	614	0xF800–0x07FF (-2048–2047)
1	0	0	± 4.0 Ga	415	0xF800–0x07FF (-2048–2047)
1	0	1	± 4.6 Ga	361	0xF800–0x07FF (-2048–2047)
1	1	0	± 5.5 Ga	307	0xF800–0x07FF (-2048–2047)
1	1	1	± 7.9 Ga	219	0xF800–0x07FF (-2048–2047)

Table 12: Gain Settings



# HMC5883

## Mode Register

The mode register is an 8-bit register from which data can be read or to which data can be written. This register is used to select the operating mode of the device. MR0 through MR7 indicate bit locations, with *MR* denoting the bits that are in the mode register. MR7 denotes the first bit of the data stream. The number in parenthesis indicates the default value of that bit.

MR7	MR6	MR5	MR4	MR3	MR2	MR1	MR0
(0)	(0)	(0)	(0)	(0)	(0)	MD1 (0)	MD0 (1)

Table 14: Mode Register

Location	Name	Description
MR7 to MR2	0	These bits must be cleared for correct operation.
MR1 to MR0	MD1 to MD0	Mode Select Bits. These bits select the operation mode of this device.

Table 15: Mode Register Bit Designations

MD1	MD0	Mode
0	0	Continuous-Measurement Mode. In continuous-measurement mode, the device continuously performs measurements and places the result in the data register. RDY goes high when new data is placed in all three registers. After a power-on or a write to the mode or configuration register, the first measurement set is available from all three data output registers after a period of $2/f_{DO}$ and subsequent measurements are available at a frequency of $f_{DO}$ , where $f_{DO}$ is the frequency of data output.
0	1	Single-Measurement Mode (default). When single-measurement mode is selected, device performs a single measurement, sets RDY high and returned to sleep mode. Mode register returns to sleep mode bit values. The measurement remains in the data output register and RDY remains high until the data output register is read or another measurement is performed.
1	0	Idle Mode. Device is placed in idle mode.
1	1	Sleep Mode. Device is placed in sleep mode.

Table 16: Operating Modes

# HMC5883

## Data Output X Registers A and B

The data output X registers are two 8-bit registers, data output register A and data output register B. These registers store the measurement result from channel X. Data output X register A contains the MSB from the measurement result, and data output X register B contains the LSB from the measurement result. The value stored in these two registers is a 16-bit value in 2's complement form, whose range is 0xF800 to 0x07FF. DXRA0 through DXRA7 and DXRB0 through DXRB7 indicate bit locations, with *DXRA* and *DXRB* denoting the bits that are in the data output X registers. DXRA7 and DXRB7 denote the first bit of the data stream. The number in parenthesis indicates the default value of that bit.

In the event the ADC reading overflows or underflows for the given channel, or if there is a math overflow during the bias measurement, this data register will contain the value -4096 in 2's complement form. This register value will clear when after the next valid measurement is made.

<b>DXRA7</b>	<b>DXRA6</b>	<b>DXRA5</b>	<b>DXRA4</b>	<b>DXRA3</b>	<b>DXRA2</b>	<b>DXRA1</b>	<b>DXRA0</b>
(0)	(0)	(0)	(0)	(0)	(0)	(0)	(0)
<b>DXRB7</b>	<b>DXRB6</b>	<b>DXRB5</b>	<b>DXRB4</b>	<b>DXRB3</b>	<b>DXRB2</b>	<b>DXRB1</b>	<b>DXRB0</b>
(0)	(0)	(0)	(0)	(0)	(0)	(0)	(0)

Table 17: Data Output X Registers A and B

## Data Output Y Registers A and B

The data output Y registers are two 8-bit registers, data output register A and data output register B. These registers store the measurement result from channel Y. Data output Y register A contains the MSB from the measurement result, and data output Y register B contains the LSB from the measurement result. The value stored in these two registers is a 16-bit value in 2's complement form, whose range is 0xF800 to 0x07FF. DYRA0 through DYRA7 and DYRB0 through DYRB7 indicate bit locations, with *DYRA* and *DYRB* denoting the bits that are in the data output Y registers. DYRA7 and DYRB7 denote the first bit of the data stream. The number in parenthesis indicates the default value of that bit.

In the event the ADC reading overflows or underflows for the given channel, or if there is a math overflow during the bias measurement, this data register will contain the value -4096 in 2's complement form. This register value will clear when after the next valid measurement is made.

<b>DYRA7</b>	<b>DYRA6</b>	<b>DYRA5</b>	<b>DYRA4</b>	<b>DYRA3</b>	<b>DYRA2</b>	<b>DYRA1</b>	<b>DYRA0</b>
(0)	(0)	(0)	(0)	(0)	(0)	(0)	(0)
<b>DYRB7</b>	<b>DYRB6</b>	<b>DYRB5</b>	<b>DYRB4</b>	<b>DYRB3</b>	<b>DYRB2</b>	<b>DYRB1</b>	<b>DYRB0</b>
(0)	(0)	(0)	(0)	(0)	(0)	(0)	(0)

Table 18: Data Output Y Registers A and B

## Data Output Z Registers A and B

The data output Z registers are two 8-bit registers, data output register A and data output register B. These registers store the measurement result from channel Z. Data output Z register A contains the MSB from the measurement result, and data output Z register B contains the LSB from the measurement result. The value stored in these two registers is a 16-bit value in 2's complement form, whose range is 0xF800 to 0x07FF. DZRA0 through DZRA7 and DZRB0 through DZRB7 indicate bit locations, with *DZRA* and *DZRB* denoting the bits that are in the data output Z registers. DZRA7 and DZRB7 denote the first bit of the data stream. The number in parenthesis indicates the default value of that bit.

In the event the ADC reading overflows or underflows for the given channel, or if there is a math overflow during the bias measurement, this data register will contain the value -4096 in 2's complement form. This register value will clear when after the next valid measurement is made.

<b>DZRA7</b>	<b>DZRA6</b>	<b>DZRA5</b>	<b>DZRA4</b>	<b>DZRA3</b>	<b>DZRA2</b>	<b>DZRA1</b>	<b>DZRA0</b>
(0)	(0)	(0)	(0)	(0)	(0)	(0)	(0)
<b>DZRB7</b>	<b>DZRB6</b>	<b>DZRB5</b>	<b>DZRB4</b>	<b>DZRB3</b>	<b>DZRB2</b>	<b>DZRB1</b>	<b>DZRB0</b>
(0)	(0)	(0)	(0)	(0)	(0)	(0)	(0)

Table 19: Data Output Z Registers A and B

**Data Output Register Operation**

When one or more of the output registers are read, new data cannot be placed in any of the output data registers until all six data output registers are read. This requirement also impacts DRDY and RDY, which cannot be cleared until new data is placed in all the output registers.

**Status Register**

The status register is an 8-bit read-only register. This register is used to indicate device status. SR0 through SR7 indicate bit locations, with *SR* denoting the bits that are in the status register. SR7 denotes the first bit of the data stream.

<b>SR7</b>	<b>SR6</b>	<b>SR5</b>	<b>SR4</b>	<b>SR3</b>	<b>SR2</b>	<b>SR1</b>	<b>SR0</b>
(0)	(0)	(0)	(0)	(0)	REN (0)	LOCK (0)	RDY(0)

Table 20: Status Register

<b>Location</b>	<b>Name</b>	<b>Description</b>
SR7 to SR3	0	These bits must be cleared for correct operation.
SR2	REN	Regulator Enabled Bit. This bit is set when the internal voltage regulator is enabled. This bit is cleared when the internal regulator is disabled.
SR1	LOCK	Data output register lock. This bit is set when this some but not all for of the six data output registers have been read. When this bit is set, the six data output registers are locked and any new data will not be placed in these register until on of four conditions are met: one, all six have been read or the mode changed, two, a POR is issued, three, the mode is changed, or four, the measurement is changed.
SR0	RDY	Ready Bit. Set when data is written to all six data registers. Cleared when device initiates a write to the data output registers, when in off mode, and after one or more of the data output registers are written to. When RDY bit is clear it shall remain cleared for a minimum of 5 μs. DRDY pin can be used as an alternative to the status register for monitoring the device for measurement data.

Table 21: Status Register Bit Designations

# HMC5883

## Identification Register A

The identification register A is used to identify the device. IRA0 through IRA7 indicate bit locations, with *IRA* denoting the bits that are in the identification register A. IRA7 denotes the first bit of the data stream. The number in parenthesis indicates the default value of that bit.

The identification value for this device is stored in this register. This is a read-only register.

Register values. ASCII value *H*

IRA7	IRA6	IRA5	IRA4	IRA3	IRA2	IRA1	IRA0
0	1	0	0	1	0	0	0

Table 22: Identification Register A Default Values

## Identification Register B

The identification register B is used to identify the device. IRB0 through IRB7 indicate bit locations, with *IRB* denoting the bits that are in the identification register A. IRB7 denotes the first bit of the data stream.

Register values. ASCII value *4*

IRB7	IRB6	IRB5	IRB4	IRB3	IRB2	IRB1	IRB0
0	0	1	1	0	1	0	0

Table 23: Identification Register B Default Values

## Identification Register C

The identification register C is used to identify the device. IRC0 through IRC7 indicate bit locations, with *IRC* denoting the bits that are in the identification register A. IRC7 denotes the first bit of the data stream.

Register values. ASCII value *3*

IRC7	IRC6	IRC5	IRC4	IRC3	IRC2	IRC1	IRC0
0	0	1	1	0	0	1	1

Table 24: Identification Register C Default Values

# HMC5883

## I<sup>2</sup>C COMMUNICATION PROTOCOL

The HMC5883 communicates via a two-wire I2C bus system as a slave device. The HMC5883 uses a simple protocol with the interface protocol defined by the I2C bus specification, and by this document. The data rate is at the standard-mode 100kbps or 400kbps rates as defined in the I2C Bus Specifications. The bus bit format is an 8-bit Data/Address send and a 1-bit acknowledge bit. The format of the data bytes (payload) shall be case sensitive ASCII characters or binary data to the HMC5883 slave, and binary data returned. Negative binary values will be in two's complement form. The default (factory) HMC5883 7-bit slave address is 0x3C for write operations, or 0x3D for read operations.

The HMC5883 Serial Clock (SCL) and Serial Data (SDA) lines have optional internal pull-up resistors, but require resistive pull-ups (Rp) between the master device (usually a host microprocessor) and the HMC5883. Pull-up resistance values of about 10k ohms are recommended with a nominal 1.8-volt digital supply voltage (DVDD). Other values may be used as defined in the I2C Bus Specifications or with the internal 50k ohm pull-up resistors (SDAP, SCLP) that can be tied to DVDD.

The SCL and SDA lines in this bus specification can be connected to a host of devices. The bus can be a single master to multiple slaves, or it can be a multiple master configuration. All data transfers are initiated by the master device which is responsible for generating the clock signal, and the data transfers are 8 bit long. All devices are addressed by I2C's unique 7 bit address. After each 8-bit transfer, the master device generates a 9 th clock pulse, and releases the SDA line. The receiving device (addressed slave) will pull the SDA line low to acknowledge (ACK) the successful transfer or leave the SDA high to negative acknowledge (NACK).

Per the I2C spec, all transitions in the SDA line must occur when SCL is low. This requirement leads to two unique conditions on the bus associated with the SDA transitions when SCL is high. Master device pulling the SDA line low while the SCL line is high indicates the Start (S) condition, and the Stop (P) condition is when the SDA line is pulled high while the SCL line is high. The I2C protocol also allows for the Restart condition in which the master device issues a second start condition without issuing a stop.

All bus transactions begin with the master device issuing the start sequence followed by the slave address byte. The address byte contains the slave address; the upper 7 bits (bits7-1), and the Least Significant bit (LSb). The LSb of the address byte designates if the operation is a read (LSb=1) or a write (LSb=0). At the 9 th clock pulse, the receiving slave device will issue the ACK (or NACK). Following these bus events, the master will send data bytes for a write operation, or the slave will clock out data with a read operation. All bus transactions are terminated with the master issuing a stop sequence.

I2C bus control can be implemented with either hardware logic or in software. Typical hardware designs will release the SDA and SCL lines as appropriate to allow the slave device to manipulate these lines. In a software implementation, care must be taken to perform these tasks in code.

## OPERATIONAL EXAMPLES

The HMC5883 has a fairly quick stabilization time from no voltage to stable and ready for data retrieval. The nominal 8.3 milli-seconds with the factory default single measurement mode means that the six bytes of magnetic data registers (DXRA, DXRB, DZRA, DZRB, DYRA, and DYRB) are filled with a valid first measurement.

To change the measurement mode to continuous measurement mode, after the 8.3 milli-second power-up time send the three bytes:

```
0x3C 0x02 0x00
```

This writes the 00 into the second register or mode register to switch from single to continuous measurement mode setting. With the data rate at the factory default of 15Hz updates, a 67 milli-second typical delay should be allowed by the I2C master before querying the HMC5843 data registers for new measurements. To clock out the new data, send:

0x3D, and clock out DXRA, DXRB, DZRA, DZRB, DYRA, and DYRB located in registers 3 through 8. The HMC5883 will automatically re-point back to register 3 for the next 0x3D query. All six data registers must be read properly before new data can be placed in any of these data registers.

# HMC5883

## SELF TEST OPERATION

To check the HMC5883 for proper operation, a self test feature is incorporated in which the sensor offset straps are excited to create a nominal field strength (bias field) to be measured. To implement this self test, the least significant bits (MS1 and MS0) of configuration register A are changed from 00 to 01.

Then, by placing the mode register into single-measurement mode (0x01), two data acquisition cycles will be made on each magnetic vector. The first acquisition will be a set pulse followed shortly by measurement data of the external field. The second acquisition will have the offset strap excited (about 5.5mA) in the positive bias mode for X and Y axes and the negative bias mode for Z axis to create about a  $\pm 0.6$  gauss self test field plus the external field. The first acquisition values will be subtracted from the second acquisition, and the net measurement will be placed into the data output registers.

If the configuration register B is left at the factory default value of 0x20, values around +655 ADC counts (0.64 Ga \* 1024 counts/Ga) will be placed in the X and Y data output registers (around -604 in Z data output register). To leave the self test mode, change MS1 and MS0 bit of the configuration register A back to 00. Also change the mode register if single-measurement mode is not the intended mode of operation.

## SCALE FACTOR CALIBRATION

Using the method described above in section SELF TEST OPERATION, user can scale sensors' sensitivity to match each other. Since placing device in positive bias mode (or alternatively negative bias mode) applies a known artificial field on all three axes, the resulting ADC measurement in data output registers can be used to scale the sensors.

Alternatively, the built-in self test can be used to periodically compensate the scaling errors due to temperature variations. A compensation factor can be found by comparing the self test outputs with the ones obtained at a known temperature. For example, if the self test output is 615 at room temperature and 630 at the current temperature then a scale factor of (615/630) should be applied to all current magnetic readings. A temperature sensor is not required using this method.

## EXTERNAL CAPACITORS

The two external capacitors should be ceramic type construction with low ESR characteristics. The exact ESR values are not critical but values less than 200 milli-ohms are recommended. Reservoir capacitor C1 is nominally 4.7  $\mu$ F in capacitance, with the set/reset capacitor C2 nominally 0.22  $\mu$ F in capacitance. Low ESR characteristics may not be in many small SMT ceramic capacitors (0402), so be prepared to up-size the capacitors to gain Low ESR characteristics.

## ORDERING INFORMATION

Ordering Number	Product
HMC5883	3-Axis Digital Compass IC
HMC5883-TR	Tape and Reel 2.5k pieces/reel

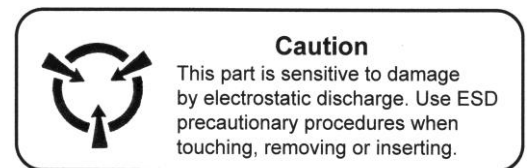

**CAUTION: ESDS CAT. 1B**

## FIND OUT MORE

For more information on Honeywell's Magnetic Sensors visit us online at [www.honeywell.com/magneticsensors](http://www.honeywell.com/magneticsensors) or contact us at 800-323-8295 (763-954-2474 internationally).

The application circuits herein constitute typical usage and interface of Honeywell product. Honeywell does not warranty or assume liability of customer-designed circuits derived from this description or depiction.

Honeywell reserves the right to make changes to improve reliability, function or design. Honeywell does not assume any liability arising out of the application or use of any product or circuit described herein; neither does it convey any license under its patent rights nor the rights of others.

U.S. Patents 4,441,072, 4,533,872, 4,569,742, 4,681,812, 4,847,584 and 6,529,114 apply to the technology described

Honeywell  
12001 Highway 55  
Plymouth, MN 55441  
Tel: 800-323-8295  
[www.honeywell.com/magneticsensors](http://www.honeywell.com/magneticsensors)

Form # 900405 Rev A  
March 2010  
©2010 Honeywell International Inc.

**Honeywell**