



Chipsmall Limited consists of a professional team with an average of over 10 year of expertise in the distribution of electronic components. Based in Hongkong, we have already established firm and mutual-benefit business relationships with customers from,Europe,America and south Asia,supplying obsolete and hard-to-find components to meet their specific needs.

With the principle of “Quality Parts,Customers Priority,Honest Operation,and Considerate Service”,our business mainly focus on the distribution of electronic components. Line cards we deal with include Microchip,ALPS,ROHM,Xilinx,Pulse,ON,Everlight and Freescale. Main products comprise IC,Modules,Potentiometer,IC Socket,Relay,Connector.Our parts cover such applications as commercial,industrial, and automotives areas.

We are looking forward to setting up business relationship with you and hope to provide you with the best service and solution. Let us make a better world for our industry!



Contact us

Tel: +86-755-8981 8866 Fax: +86-755-8427 6832

Email & Skype: info@chipsmall.com Web: www.chipsmall.com

Address: A1208, Overseas Decoration Building, #122 Zhenhua RD., Futian, Shenzhen, China



Analog Devices Welcomes Hittite Microwave Corporation

NO CONTENT ON THE ATTACHED DOCUMENT HAS CHANGED

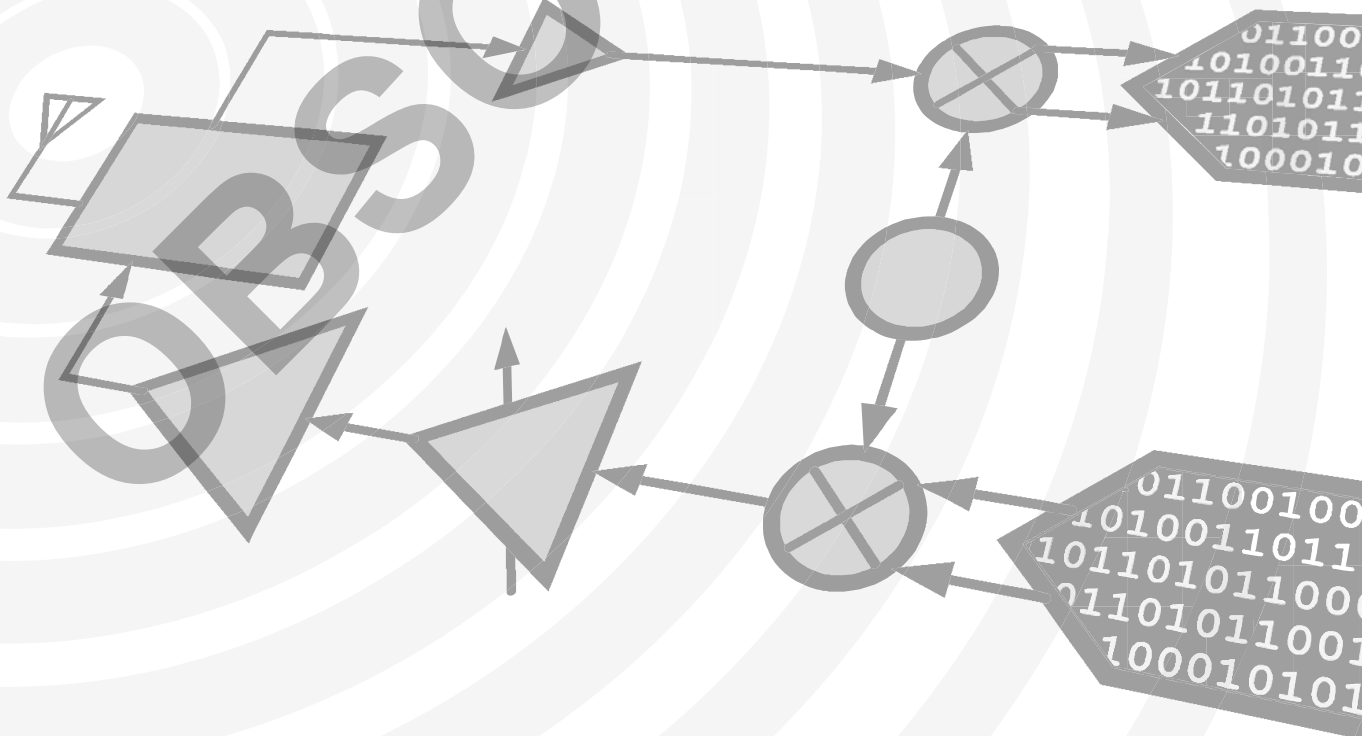

THIS PAGE INTENTIONALLY LEFT BLANK

OBSOLETE



HMC230MS8 / 230MS8E

4 dB LSB GaAs MMIC 3-BIT DIGITAL ATTENUATOR, 0.75 - 2.0 GHz

Typical Applications

The HMC230MS8 / HMC230MS8E is ideal for:

- Cellular
- PCS, ISM, MMDS
- WLL Handset
- Base Station Infrastructure

Functional Diagram

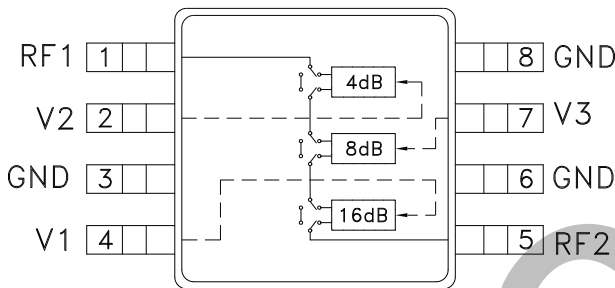

Features

- 4 dB LSB Steps to 28 dB
- Single Positive Control Per Bit
- ±0.5 dB Typical Bit Error
- Pin - For - Pin Replacement to AA100-59 Digital Attenuator

General Description

The HMC230MS8 & HMC230MS8E are broadband 3-bit positive control GaAs IC digital attenuators in 8 lead MSOP surface mount plastic packages. Covering 0.75 to 2 GHz, the insertion loss is typically less than 2 dB. The attenuator bit values are 4 (LSB), 8, and 16 dB for a total attenuation of 28 dB. Accuracy is excellent at ±0.5 dB typical with an IIP3 of up to +48 dBm. Three bit control voltage inputs, toggled between 0 and +3 to +5 volts, are used to select each attenuation state at less than 50 uA each. A single Vdd bias of +3 to +5 volts applied through an external 5K Ohm resistor is required.

Electrical Specifications,

$T_A = +25^\circ C$, $V_{dd} = +3V$ to $+5V$ & $V_{ctl} = 0/V_{dd}$ (Unless Otherwise Stated)

Parameter	Frequency	Min.	Typical	Max.	Units
Insertion Loss	0.75 - 1.7 GHz		1.6	1.8	dB
	1.7 - 2.0 GHz		1.8	2.1	dB
Attenuation Range	0.75 - 2.0 GHz		28		dB
Return Loss (RF1 & RF2, All Atten. States)	0.75 - 1.7 GHz	10	13		dB
	1.7 - 2.0 GHz	13	16		dB
Attenuation Accuracy: (Reference to Insertion Loss)					
4, 8, 12, 16, 20 dB States	0.75 - 1.4 GHz	± 0.3 + 3% of Atten. Setting Max			dB
24, 28 dB States	0.75 - 1.4 GHz	± 0.4 + 6% of Atten. Setting Max			dB
All Attenuation States	1.40 - 2.0 GHz	± 0.3 + 3% of Atten. Setting Max			dB
Input Power for 0.1 dB Compression	0.75 - 2.0 GHz	5V	20		dBm
		3V	19		dBm
Input Third Order Intercept (Two-Tone Input Power = 0 dBm Each)	0.75 - 2.0 GHz	5V	46		dBm
		3V	45		dBm
Switching Characteristics					
tRISE, tFALL (10/90% RF)	0.75 - 2.0 GHz		560		ns
tON, tOFF (50% CTL to 10/90% RF)			600		ns



HMC230MS8 / 230MS8E

4 dB LSB GaAs IC 3-BIT DIGITAL ATTENUATOR, 0.75 - 2.0 GHz

Insertion Loss

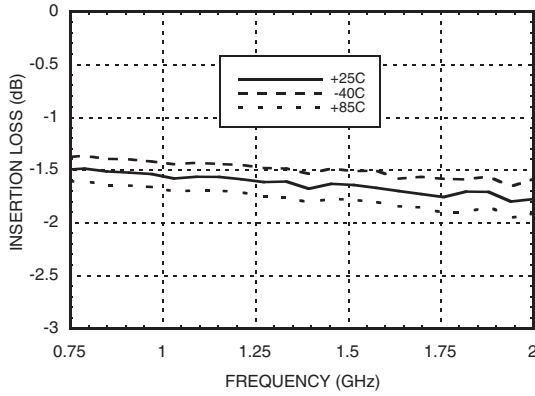

Return Loss RF1, RF2 (Only Major States are Shown)

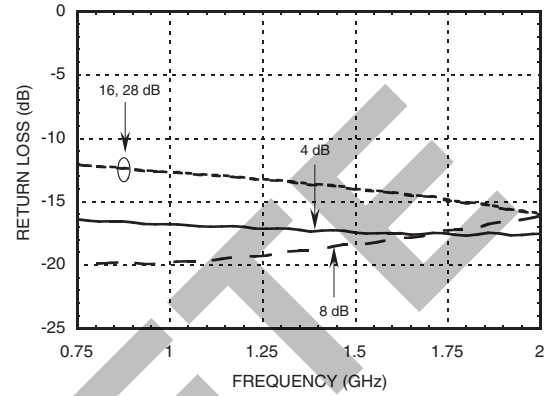

Normalized Attenuation (Only Major States are Shown)

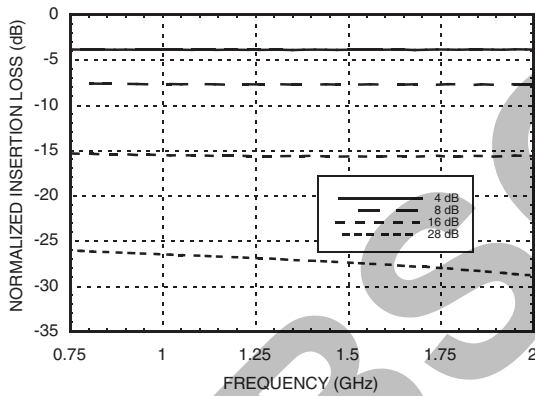

Bit Error vs. Attenuation State

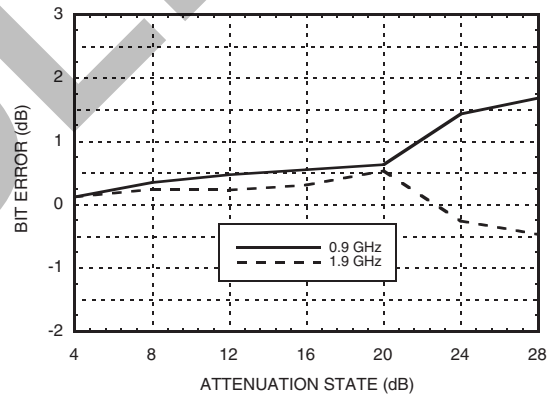

Bit Error vs. Frequency (Only Major States are Shown)

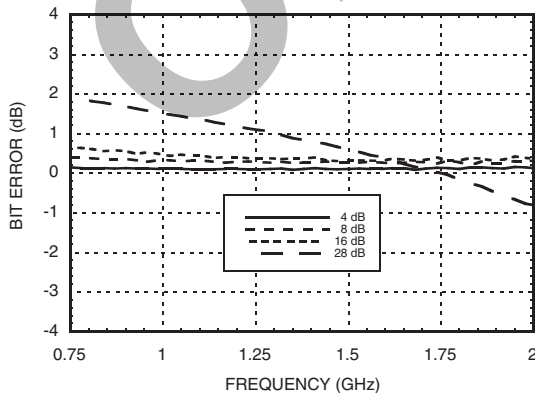

Relative Phase vs. Frequency (Only Major States are Shown)

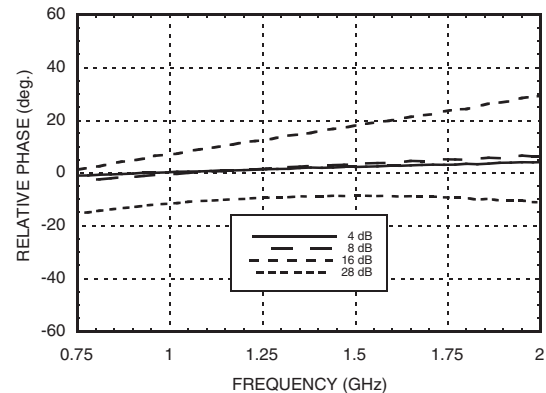

Note: All Data Typical Over Voltage (+3V to +5V) & Temperature (-40 to +85 deg C).

For price, delivery, and to place orders, please contact Hittite Microwave Corporation:
 20 Alpha Road, Chelmsford, MA 01824 Phone: 978-250-3343 Fax: 978-250-3373
 Order On-line at www.hittite.com

Control & Bias Voltages

State	Bias Condition
Low	0 to +0.2Vdc @ 20 uA Max
High	Vdd ±0.2V @ 50 uA Typ

Note: Vdd = +3V to +5V ± 0.2V

Truth Table

Control Voltage Input			Attenuation Setting RF1 - RF2
V1 16 dB	V2 4 dB	V3 8 dB	
High	High	High	Reference I.L.
High	Low	High	4 dB
High	High	Low	8 dB
Low	High	High	16 dB
Low	Low	Low	28 dB Max. Atten.

Any combination of the above states will provide an attenuation approximately equal to the sum of the bits selected.

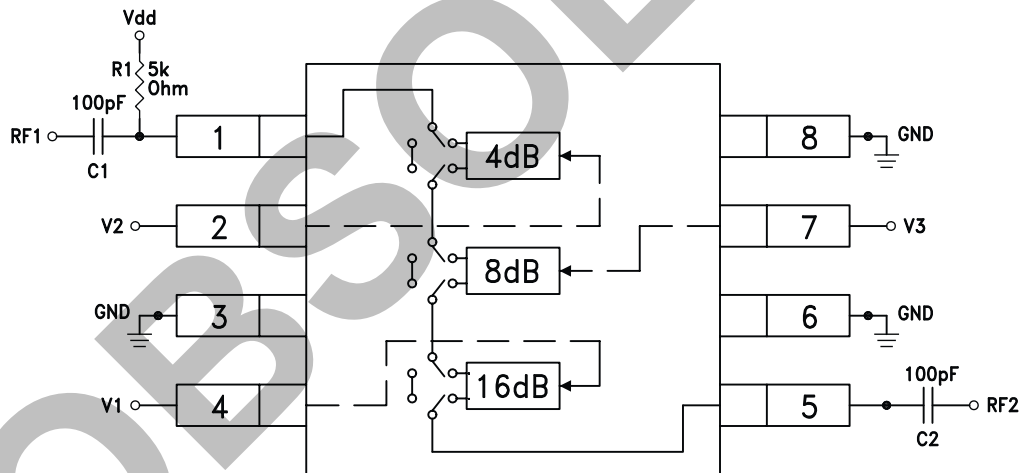
Application Circuit

DC blocking capacitors C1 & C2 are required on RF1 & RF2. Choose C1 = C2 = 100 ~ 300 pF to allow lowest customer specific frequency to pass with minimal loss. R1 = 5K Ohm is required to supply voltage to the circuit through either PIN 1 or PIN 5.

Absolute Maximum Ratings

Control Voltage (V1, V2, V3)	Vdd to +0.5 Vdc
Bias Voltage (Vdd)	+8.0 Vdc
Storage Temperature	-65 to +150 °C
Operating Temperature	-40 to +85 °C
RF Input Power (0.75 - 2 GHz)	+26 dBm



ELECTROSTATIC SENSITIVE DEVICE
OBSERVE HANDLING PRECAUTIONS

Outline Drawing

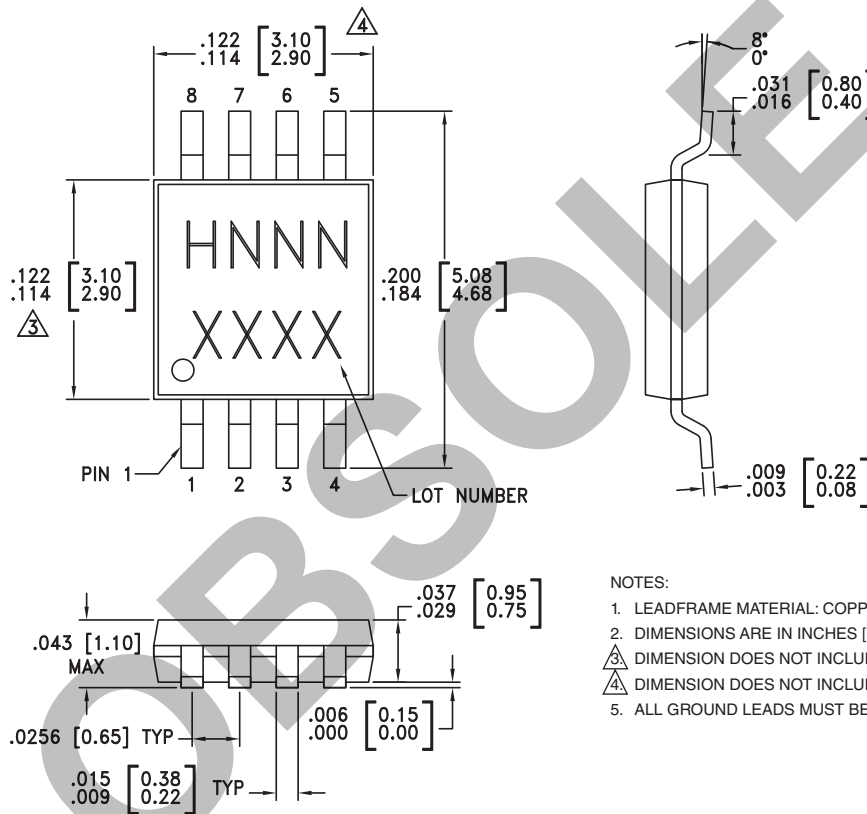

NOTES:

1. LEADFRAME MATERIAL: COPPER ALLOY
2. DIMENSIONS ARE IN INCHES [MILLIMETERS].
3. DIMENSION DOES NOT INCLUDE MOLDFLASH OF 0.15mm PER SIDE.
4. DIMENSION DOES NOT INCLUDE MOLDFLASH OF 0.25mm PER SIDE.
5. ALL GROUND LEADS MUST BE SOLDERED TO PCB RF GROUND.

Package Information

Part Number	Package Body Material	Lead Finish	MSL Rating	Package Marking ^[3]
HMC230MS8	Low Stress Injection Molded Plastic	Sn/Pb Solder	MSL1 ^[1]	H230 XXXX
HMC230MS8E	RoHS-compliant Low Stress Injection Molded Plastic	100% matte Sn	MSL1 ^[2]	H230 XXXX

[1] Max peak reflow temperature of 235 °C

[2] Max peak reflow temperature of 260 °C

[3] 4-Digit lot number XXXX

For price, delivery, and to place orders, please contact Hittite Microwave Corporation:
20 Alpha Road, Chelmsford, MA 01824 Phone: 978-250-3343 Fax: 978-250-3373
Order On-line at www.hittite.com

Evaluation Circuit Board

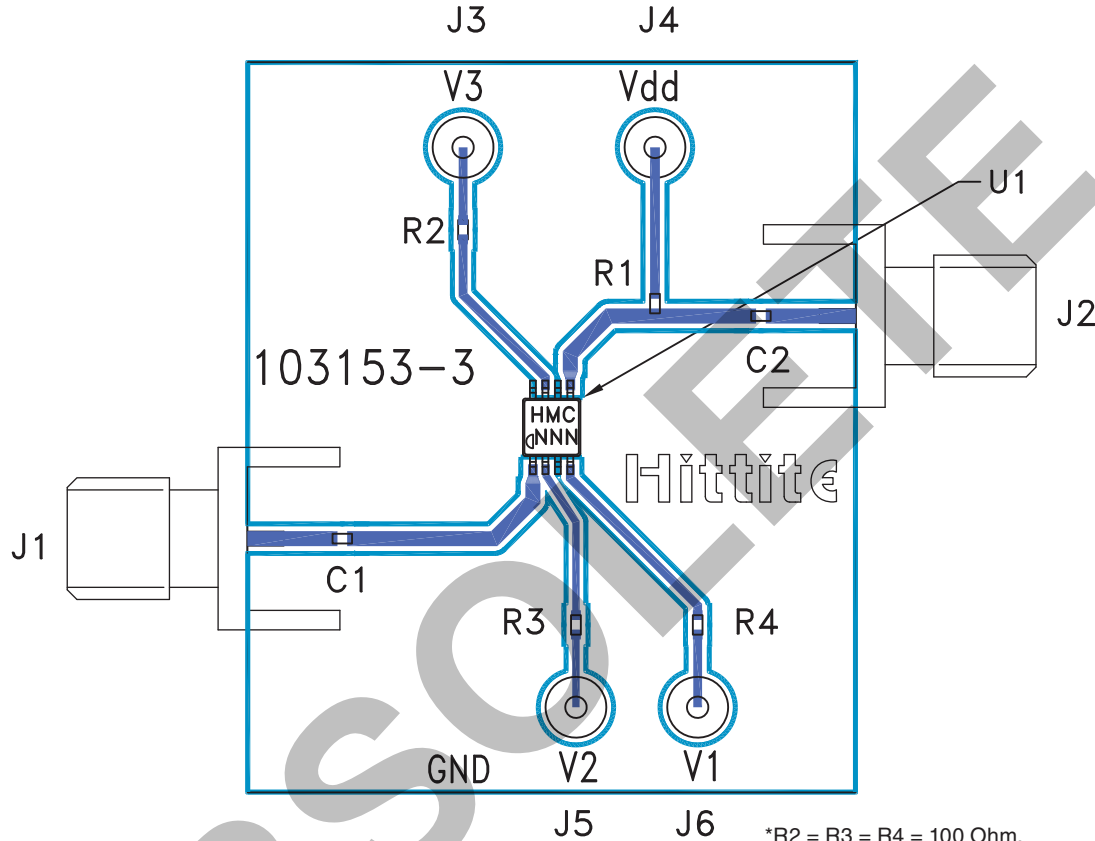

*R2 = R3 = R4 = 100 Ohm.
These Resistors are optional and may be used to enhance decoupling of the RF path from the control inputs.

List of Materials for Evaluation PCB 103155 [1]

Item	Description
J1 - J2	PCB Mount SMA Connector
J3 - J6	DC Pin
R1	5k Ohm Resistor, 0402 Chip
R2, R3, R4	100 Ohm Resistor, 0402 Chip
C1, C2	0402 Chip Capacitor, Select for Lowest Frequency of Operation
U1	HMC230MS8 / HMC230MS8E Digital Attenuator
PCB [2]	103153 Evaluation PCB 1.25" x 1.5"

[1] Reference this number when ordering complete evaluation PCB

[2] Circuit Board Material: Rogers 4350

The circuit board used in the final application should use RF circuit design techniques. Signal lines should have 50 ohm impedance while the package ground leads should be connected directly to the ground plane similar to that shown. A sufficient number of via holes should be used to connect the top and bottom ground planes. The evaluation circuit board as shown is available from Hittite Microwave Corporation upon request.



Notes:

OBSOLETE