



Chipsmall Limited consists of a professional team with an average of over 10 year of expertise in the distribution of electronic components. Based in Hongkong, we have already established firm and mutual-benefit business relationships with customers from,Europe,America and south Asia,supplying obsolete and hard-to-find components to meet their specific needs.

With the principle of "Quality Parts,Customers Priority,Honest Operation,and Considerate Service",our business mainly focus on the distribution of electronic components. Line cards we deal with include Microchip,ALPS,ROHM,Xilinx,Pulse,ON,Everlight and Freescale. Main products comprise IC,Modules,Potentiometer,IC Socket,Relay,Connector.Our parts cover such applications as commercial,industrial, and automotives areas.

We are looking forward to setting up business relationship with you and hope to provide you with the best service and solution. Let us make a better world for our industry!



## Contact us

Tel: +86-755-8981 8866 Fax: +86-755-8427 6832

Email & Skype: info@chipsmall.com Web: www.chipsmall.com

Address: A1208, Overseas Decoration Building, #122 Zhenhua RD., Futian, Shenzhen, China



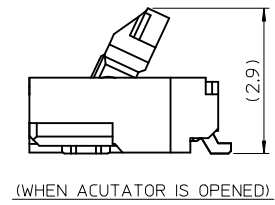
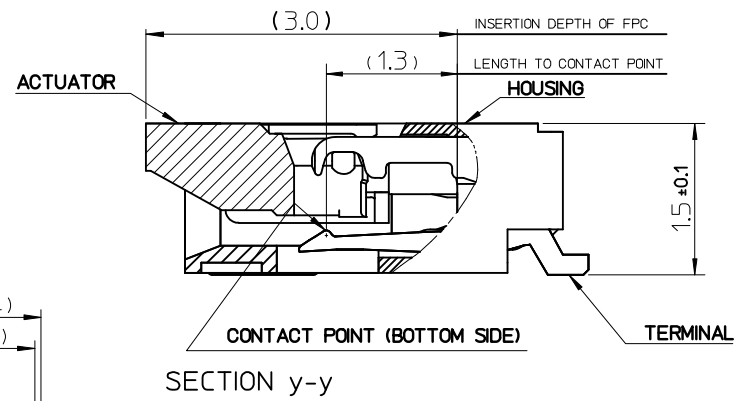
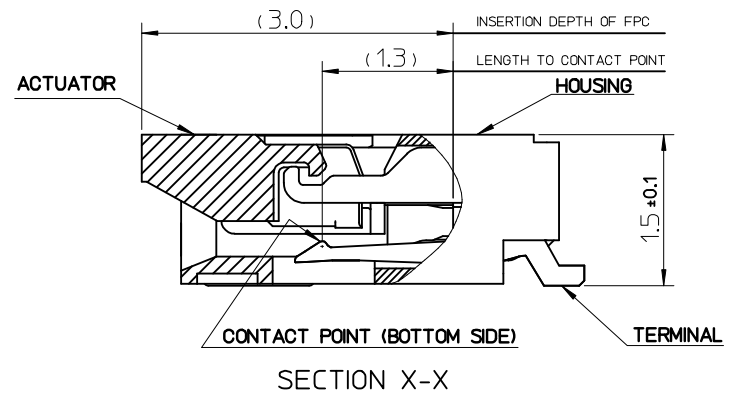
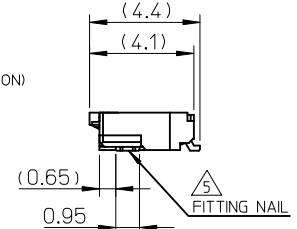
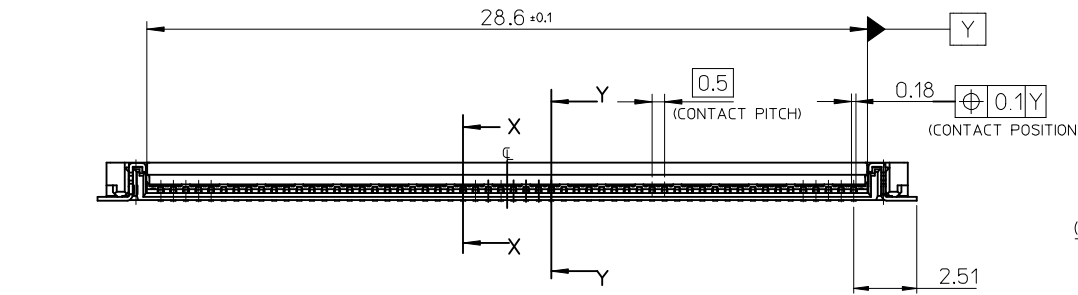
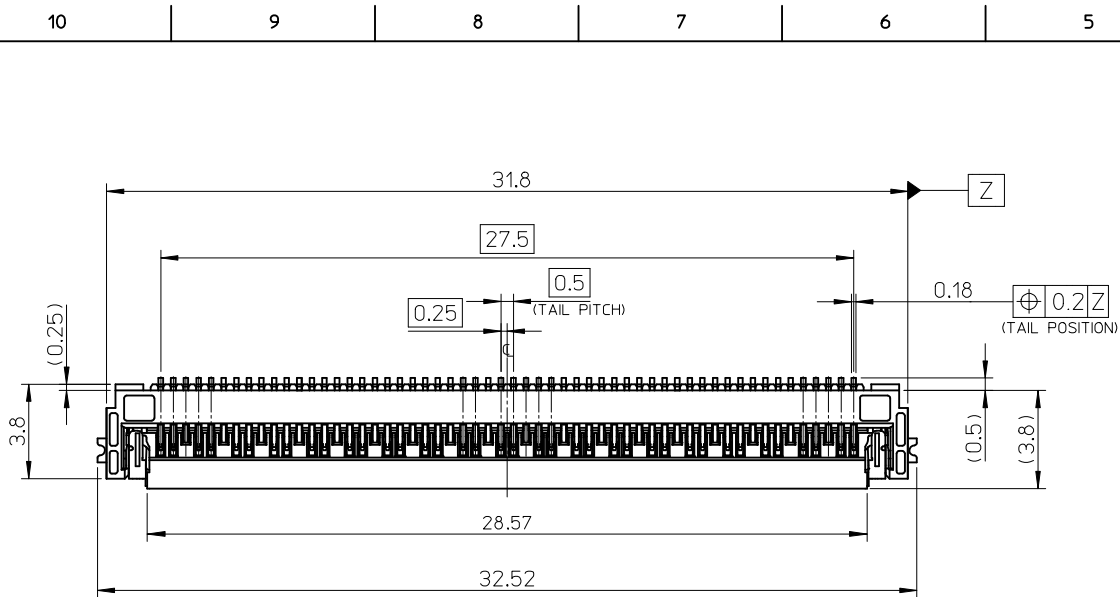

1041125617	56
ORDER No.	Ck1

<b>NEW RELEASED</b> EC NO: KOR2013-0022 DRWN: JHCHANG 2012/08/16 CHKD: APPR: YSK1M02 2012/08/31	QUALITY SYMBOLS	GENERAL TOLERANCES (UNLESS SPECIFIED) <table border="1"> <tr> <td></td> <td>mm</td> <td>INCH</td> </tr> <tr> <td>4 PLACES</td> <td>± 0.1</td> <td>± 0.004</td> </tr> <tr> <td>3 PLACES</td> <td>± 0.05</td> <td>± 0.002</td> </tr> <tr> <td>2 PLACES</td> <td>± 0.02</td> <td>± 0.001</td> </tr> <tr> <td>1 PLACE</td> <td>± 0.01</td> <td>± 0.0005</td> </tr> </table> ANGULAR ± 1°		mm	INCH	4 PLACES	± 0.1	± 0.004	3 PLACES	± 0.05	± 0.002	2 PLACES	± 0.02	± 0.001	1 PLACE	± 0.01	± 0.0005	DIMENSION STYLE	SCALE	DESIGN UNITS	THIRD ANGLE PROJECTION
			mm	INCH																	
	4 PLACES		± 0.1	± 0.004																	
	3 PLACES		± 0.05	± 0.002																	
2 PLACES	± 0.02	± 0.001																			
1 PLACE	± 0.01	± 0.0005																			
		MM ONLY		METRIC																	
		DRAWN BY: JHCHANG CHECKED BY: KSK1M APPROVED BY: YSK1M02 DATE: 2012/08/16 DATE: 2012/08/16 DATE: 2012/08/31	TITLE	0.5MM FPC/FFC FRONTFLIP SLIM CONN. 56P (H=1.5) HOUSING ASS'Y																	
		SEE TABLE	DOCUMENT NO.	MOLEX INCORPORATED SD-104112-001																	
		DRAFT WHERE APPLICABLE MUST REMAIN WITHIN DIMENSIONS	MATERIAL NO. SIZE: A3	SHEET NO. 1 OF 3																	

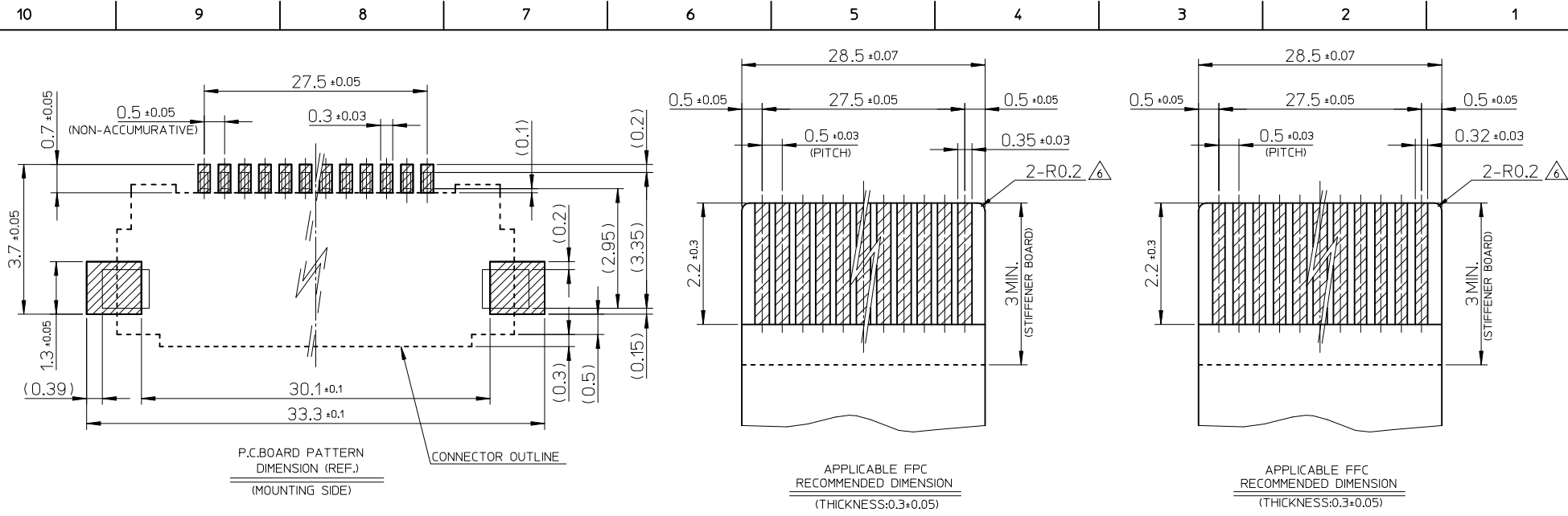

**NOTES**

1. MATERIAL

HOUSING LCP GLASS FILLED,UL94V-0(NATURAL)  
 ACTUATOR PPS GLASS FILLED,UL94V-0(BLACK)  
 (CHLORINE CONTROLLED MATERIAL)  
 TERMINAL PHOSPHOR BRONZE  
 FITTING NAIL PHOSPHOR BRONZE

2. PLATING

TERMINAL : SELECTIVE GOLD[Au] OVER NICKEL[Ni] PLATING.  
 CONTACT AREA : GOLD[Au] 0.1 MICROMETER MIN. OVER  
 NICKEL[Ni] 1.0 MICROMETER MIN.(UNDER PLATING)  
 SOLDER AREA : GOLD[Au] 0.05 MICROMETER MIN. OVER  
 NICKEL[Ni] 1.0 MICROMETER MIN.(UNDER PLATING)  
 FITTING NAIL : TIN[Sn] OVER NICKEL[Ni] PLATING.  
 Tin[Sn] 1~3 MICROMETER.  
 NICKEL[Ni] 1~3 MICROMETER (UNDER PLATING)

3. PRODUCT SPECIFICATION : PS-104112-001

PACKING SPECIFICATION : PK-104112-001

4. ACTUATOR IS CLOSED IN THE EMBOSSED PACKING

5. FITTING NAIL FOR PREVENTION OF PEELING OF PCB PATTERN.

△ R0.3 MUST NOT BE OVERLAPPED TO PATTERN OF FPC.

7. N : CIRCUIT.

8. COPLANARITY IS 0.10MAX.

ABOUT FPC/FFC

RECOMMENDED PUNCHER DIRECTION : FROM CONDUCTOR SIDE TO STIFFENER FILM SIDE.  
 RECOMMENDED CONDUCTOR THICKNESS OF SOFT COPPER FOIL : 35 μm OR 50 μm.

ABOUT FPC

RECOMMENDED MATERIAL/THICKNESS.  
 STIFFENER FILM : POLYIMIDE  
 BONDING AGENT : THERMOSETTING BONDING AGENT  
 BASE FILM THICKNESS : 25 μm  
 PLEASE PUT APPROPRIATE AMOUNT OF ADHESIVE ON THE CONTACT AREA BECAUSE THE EXTRA ADHESIVE MAY CAUSE THE DEFECT IN ELECTRICAL CONTINUITY.

ABOUT METAL MASK

RECOMMENDED METAL MASK THICKNESS : 0.12μ  
 RECOMMENDED METAL MASK OPEN RATIO : OVER 80%

<b>NEW RELEASED</b> EC NO: KOR2013-0022 DRWN: JHCHANG 2012/08/16 CHKD: APPR: YSK1M02 2012/08/31 DESCRIPTION KOR2013-0022	<b>QUALITY SYMBOLS</b> 	<b>GENERAL TOLERANCES (UNLESS SPECIFIED)</b>		<b>DIMENSION STYLE</b> <b>MM ONLY</b>	<b>SCALE</b> <b>5:1</b>	<b>DESIGN UNITS</b> <b>METRIC</b>	<b>THIRD ANGLE PROJECTION</b>																													
		<table border="1"> <thead> <tr> <th></th> <th>mm</th> <th>INCH</th> </tr> </thead> <tbody> <tr> <td>4 PLACES</td> <td>± ---</td> <td>± ---</td> </tr> <tr> <td>3 PLACES</td> <td>± 0.005</td> <td>± ---</td> </tr> <tr> <td>2 PLACES</td> <td>± 0.05</td> <td>± ---</td> </tr> <tr> <td>1 PLACE</td> <td>± 0.1</td> <td>± ---</td> </tr> </tbody> </table>		mm	INCH	4 PLACES	± ---	± ---	3 PLACES	± 0.005	± ---	2 PLACES	± 0.05	± ---	1 PLACE	± 0.1	± ---	<table border="1"> <thead> <tr> <th>DRAWN BY</th> <th>DATE</th> <th>TITLE</th> </tr> </thead> <tbody> <tr> <td>JHCHANG</td> <td>2012/08/16</td> <td rowspan="4"> <b>0.5MM FPC/FFC FRONTFLIP SLIM CONN. 56P (H=1.5) HOUSING ASS'Y</b> </td> </tr> <tr> <td>CHECKED BY</td> <td>DATE</td> </tr> <tr> <td>KSK1M</td> <td>2012/08/16</td> </tr> <tr> <td>APPROVED BY</td> <td>DATE</td> </tr> <tr> <td>YSK1M02</td> <td>2012/08/31</td> <td> <b>MOLEX INCORPORATED</b> </td> </tr> </tbody> </table>	DRAWN BY	DATE	TITLE	JHCHANG	2012/08/16	<b>0.5MM FPC/FFC FRONTFLIP SLIM CONN. 56P (H=1.5) HOUSING ASS'Y</b>	CHECKED BY	DATE	KSK1M	2012/08/16	APPROVED BY	DATE	YSK1M02	2012/08/31	<b>MOLEX INCORPORATED</b>	<b>MATERIAL NO.</b> <b>SEE SHEET 1</b>	<b>DOCUMENT NO.</b> <b>SD-104112-001</b>	<b>SHEET NO.</b> <b>2 OF 3</b>
		mm	INCH																																	
	4 PLACES	± ---	± ---																																	
3 PLACES	± 0.005	± ---																																		
2 PLACES	± 0.05	± ---																																		
1 PLACE	± 0.1	± ---																																		
DRAWN BY	DATE	TITLE																																		
JHCHANG	2012/08/16	<b>0.5MM FPC/FFC FRONTFLIP SLIM CONN. 56P (H=1.5) HOUSING ASS'Y</b>																																		
CHECKED BY	DATE																																			
KSK1M	2012/08/16																																			
APPROVED BY	DATE																																			
YSK1M02	2012/08/31	<b>MOLEX INCORPORATED</b>																																		
<b>DRAFT WHERE APPLICABLE MUST REMAIN WITHIN DIMENSIONS</b>	<b>SIZE</b> <b>A3</b>	<b>THIS DRAWING CONTAINS INFORMATION THAT IS PROPRIETARY TO MOLEX INCORPORATED AND SHOULD NOT BE USED WITHOUT WRITTEN PERMISSION</b>																																		

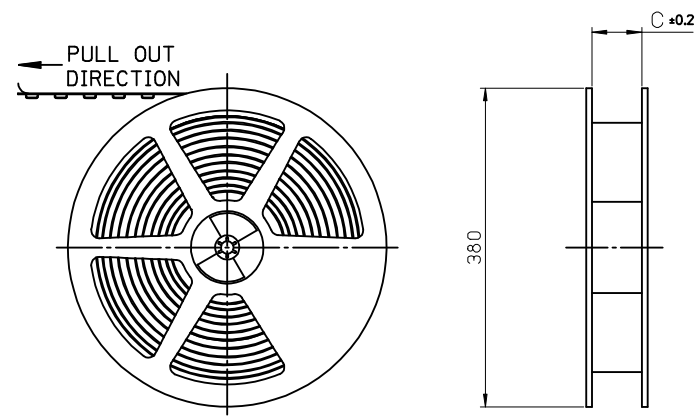
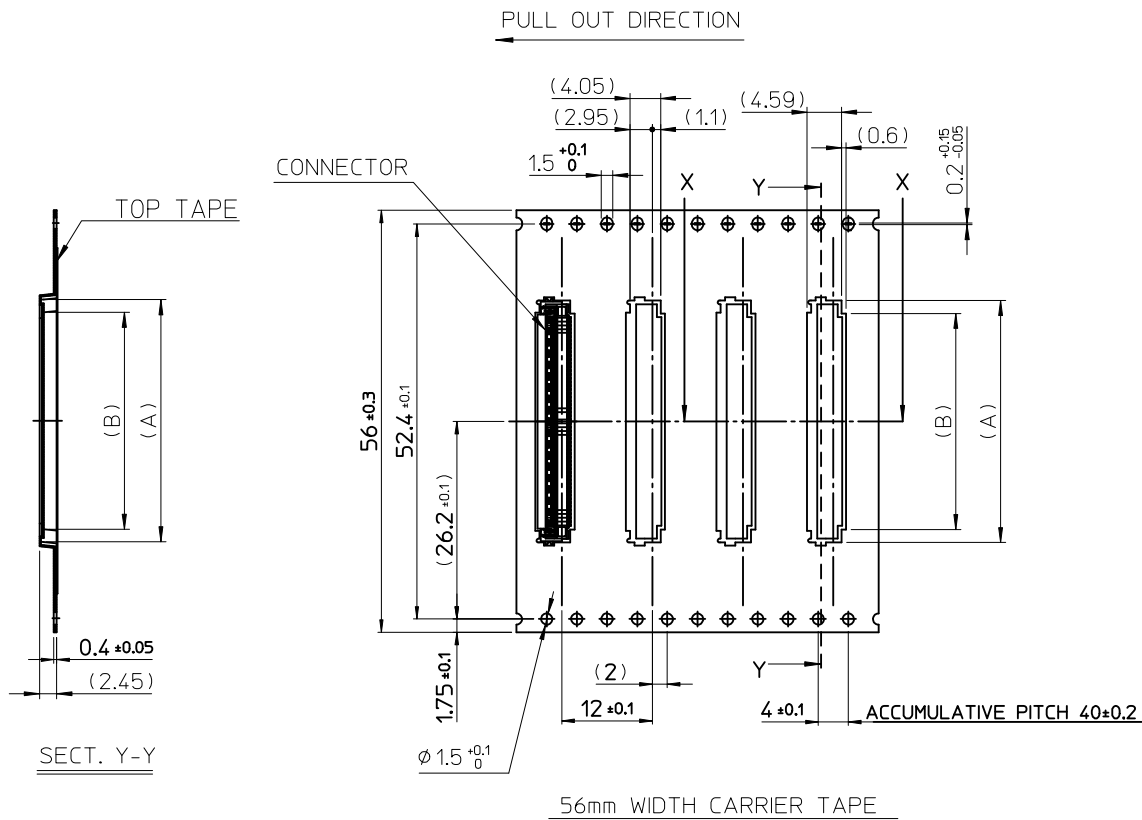

- NOTES
1. QUANTITY OF CONNECTORS : 3000PCS/REEL
  2. LEAD LENGTH

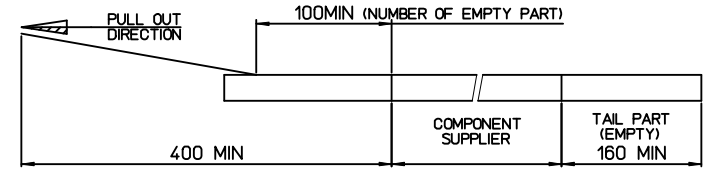

3. THIS PRODUCT IS HALOGEN FREE (LV.2)

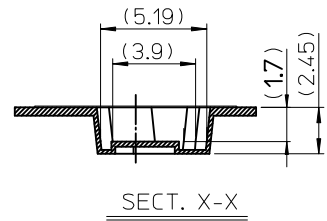

56	57.5	30.29	32.7	104112-5617	56
CARRIER TAPE WIDTH	C	(B)	(A)	ORDER No.	Ckt

<p>NEW RELEASED</p> <p>EC NO: KOR2013-0022</p> <p>DRWN: JHCHANG 2012/08/16</p> <p>CHKD:</p> <p>APPR: YSK1M02 2012/08/31</p>	<p>QUALITY SYMBOLS</p> <p>▽=0</p> <p>∇=0</p>	<p>GENERAL TOLERANCES (UNLESS SPECIFIED)</p>		<p>DIMENSION STYLE</p> <p>MM ONLY</p>		<p>SCALE</p> <p>5:1</p>		<p>DESIGN UNITS</p> <p>METRIC</p>		<p>THIRD ANGLE PROJECTION</p>		
		4 PLACES	± ---	± ---	DRAWN BY	DATE	<p>TITLE</p> <p>0.5MM FPC/FFC FRONTFLIP SLIM CONN. 56P (H=1.5) HOUSING ASS'Y</p>					
		3 PLACES	± 0.005	± ---	CHECKED BY	DATE						
		2 PLACES	± 0.05	± ---	APPROVED BY		DATE	<p>MOLEX INCORPORATED</p>				
1 PLACE	± 0.1	± ---	MATERIAL NO.		DATE	<p>DOCUMENT NO.</p> <p>SD-104112-001</p>						
<p>ANGULAR ± 1°</p>				<p>SEE SHEET 1</p>								<p>SHEET NO.</p> <p>3 OF 3</p>
<p>DRAFT WHERE APPLICABLE MUST REMAIN WITHIN DIMENSIONS</p>				<p>SIZE</p> <p>A3</p>		<p>THIS DRAWING CONTAINS INFORMATION THAT IS PROPRIETARY TO MOLEX INCORPORATED AND SHOULD NOT BE USED WITHOUT WRITTEN PERMISSION</p>						