



Chipsmall Limited consists of a professional team with an average of over 10 year of expertise in the distribution of electronic components. Based in Hongkong, we have already established firm and mutual-benefit business relationships with customers from,Europe,America and south Asia,supplying obsolete and hard-to-find components to meet their specific needs.

With the principle of “Quality Parts,Customers Priority,Honest Operation,and Considerate Service”,our business mainly focus on the distribution of electronic components. Line cards we deal with include Microchip,ALPS,ROHM,Xilinx,Pulse,ON,Everlight and Freescale. Main products comprise IC,Modules,Potentiometer,IC Socket,Relay,Connector.Our parts cover such applications as commercial,industrial, and automotives areas.

We are looking forward to setting up business relationship with you and hope to provide you with the best service and solution. Let us make a better world for our industry!



Contact us

Tel: +86-755-8981 8866 Fax: +86-755-8427 6832

Email & Skype: info@chipsmall.com Web: www.chipsmall.com

Address: A1208, Overseas Decoration Building, #122 Zhenhua RD., Futian, Shenzhen, China



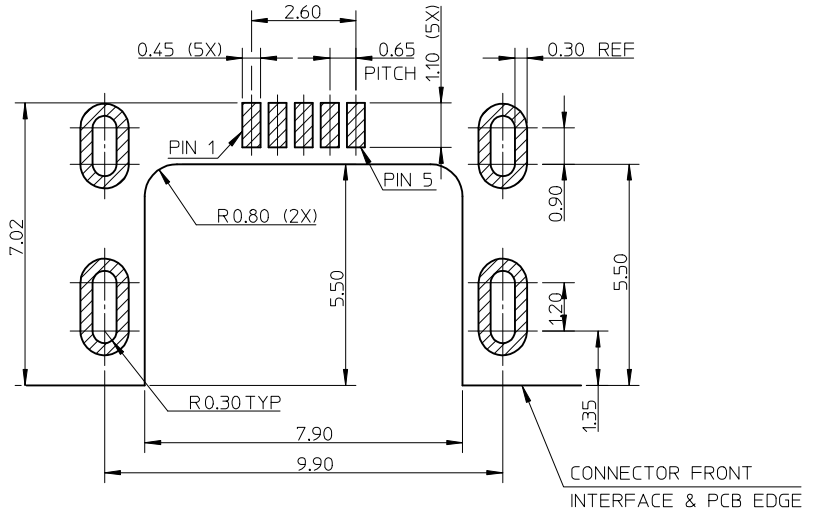
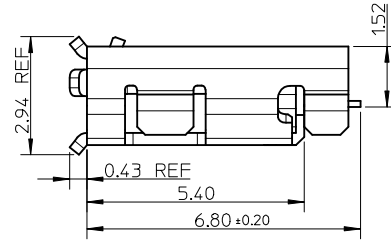
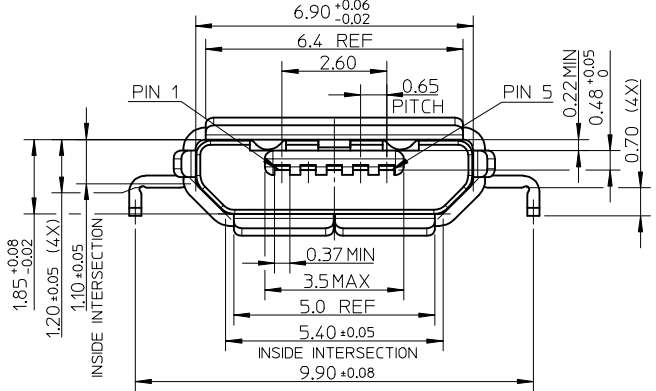
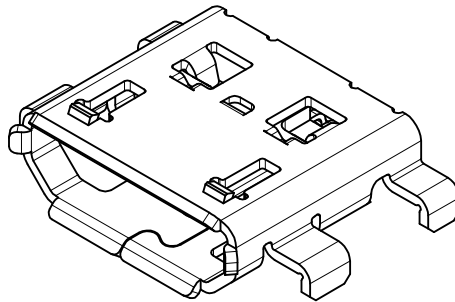
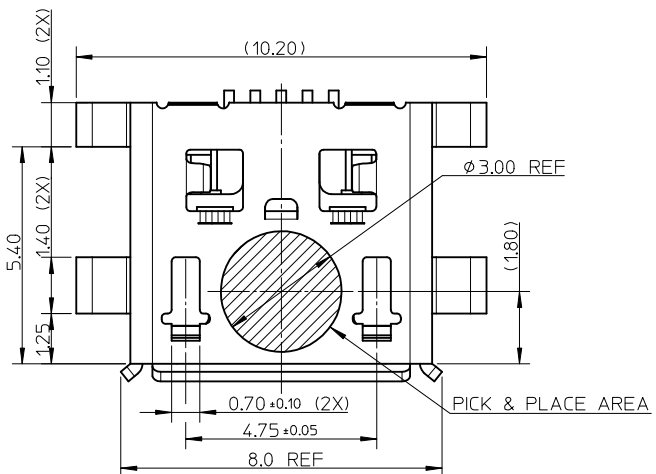

RECOMMENDED P.C.B. PATTERN LAYOUT
GENERAL TOLERANCE: ±0.05

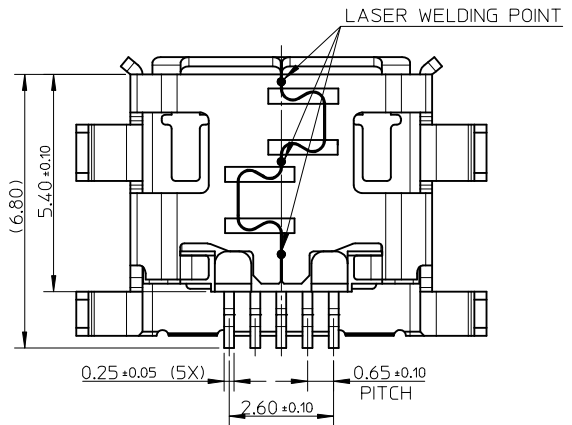

NOTES:

- MATERIAL:
HOUSING: LCP, BLACK, UL94V-0;
TERMINAL: COPPER ALLOY, THICKNESS: 0.15mm;
SHELL: STAINLESS STEEL, THICKNESS: 0.30mm.
- PLATING:
TERMINAL:
CONTACT AREA: GOLD FLASH OVER 0.75 MICRON MINIMUM Pd/Ni;
SOLDER TAIL AREA: GOLD FLASH;
UNDER PLATING: NICKEL 2.0 MICRON MINIMUM.
SHELL:
MATTE TIN 2.0 MICRON MINIMUM;
UNDER PLATING: NICKEL 1.27 MICRON MINIMUM.
- TAIL & NAIL COPLANARITY 0.08mm MAXIMUM.
- PRODUCT SPECIFICATION: PS-47642-001.
- PACKAGING SPECIFICATION: PK-47642-001.
- PRODUCT COMPLIANT TO RoHS DIRECTIVE 2002/95/EC AND ELV DIRECTIVE 2000/53/EC.

ADD PART NUMBER EC NO: SHZ013-0123 DRWN: XQZHANG CHKD: XQZHANG APPR: AYIN	2012/10/22 2012/10/22 2012/10/26	QUALITY SYMBOLS $F_A=0$ $F_B=0$ $F_C=0$	GENERAL TOLERANCES (UNLESS SPECIFIED)		DIMENSION STYLE		SCALE	DESIGN UNITS	THIRD ANGLE PROJECTION		
					MM ONLY		1:1	METRIC			
					mm	INCH	DRAWN BY		DATE	TITLE	
							XQZHANG		2012/06/21	SALES DRAWING FOR USB MICRO-B, MID MOUNT	
				3 PLACES		CHECKED BY		DATE			
				± ---		± ---		XQZHANG		2012/06/21	
				2 PLACES		APPROVED BY		DATE			
				± 0.20		AYIN		2012/10/11			
				1 PLACE		MATERIAL NO.		DOCUMENT NO.			
				± 0.25		105248-0001		SD-105248-001			
				0 PLACE		ANGULAR ± 3°		SHEET NO.			
				± ---		DRAFT WHERE APPLICABLE MUST REMAIN WITHIN DIMENSIONS		1 OF 3			
						SIZE		THIS DRAWING CONTAINS INFORMATION THAT IS PROPRIETARY TO MOLEX INCORPORATED AND SHOULD NOT BE USED WITHOUT WRITTEN PERMISSION			
						A3					

F

E

D

C

B

A

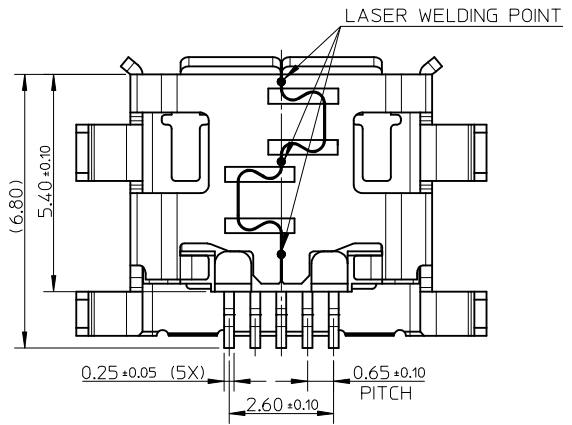
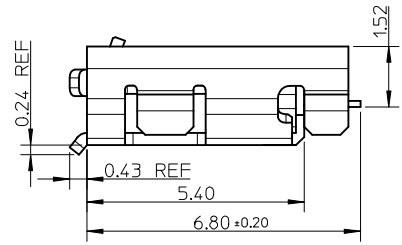
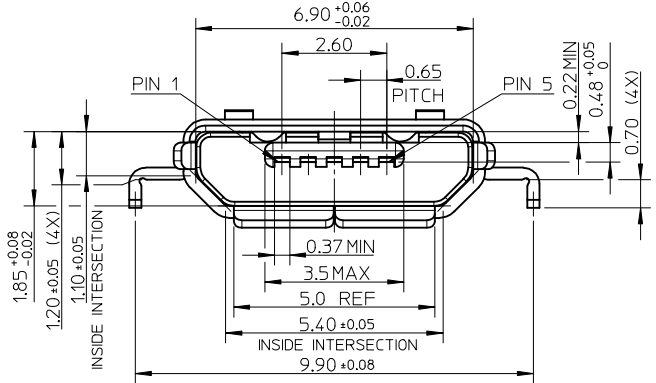
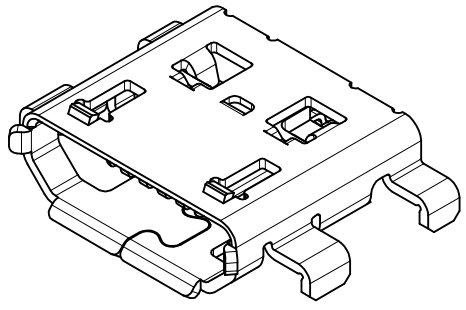
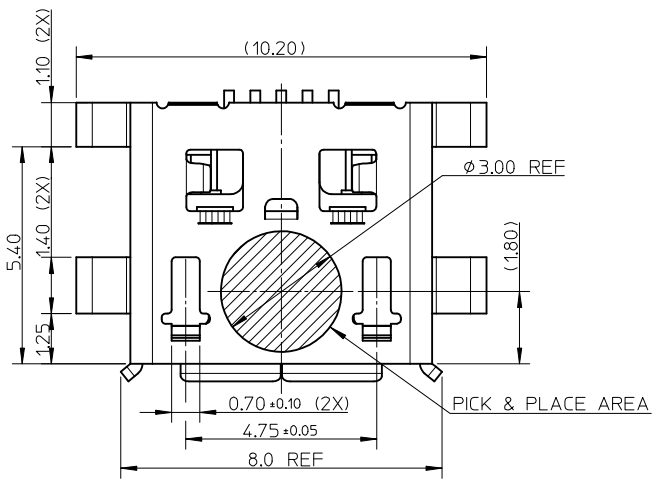

SEE SHEET 1 EC NO: SHZ013-0123 DRWN: XQZHANG CHKD: XQZHANG APPR: AYIN	2012/10/22 2012/10/22 2012/10/26	QUALITY SYMBOLS $\nabla_F = 0$ $\nabla_E = 0$ $\nabla_B = 0$	GENERAL TOLERANCES (UNLESS SPECIFIED)		DIMENSION STYLE MM ONLY		SCALE 1:1	DESIGN UNITS METRIC	THIRD ANGLE PROJECTION		
				mm	INCH	DRAWN BY XQZHANG	DATE 2012/06/21	TITLE SALES DRAWING FOR USB MICRO-B, MID MOUNT FLANGELESS TYPE			
			4 PLACES	± ---	± ---	CHECKED BY XQZHANG	DATE 2012/06/21				
			3 PLACES	± ---	± ---	APPROVED BY AYIN	DATE 2012/10/11	molex MATERIAL NO. 105248-1101 DOCUMENT NO. SD-105248-001 SHEET NO. 2 OF 3			
2 PLACES	± 0.20	± ---	DRAFT WHERE APPLICABLE MUST REMAIN WITHIN DIMENSIONS		SIZE A3	THIS DRAWING CONTAINS INFORMATION THAT IS PROPRIETARY TO MOLEX INCORPORATED AND SHOULD NOT BE USED WITHOUT WRITTEN PERMISSION					

F

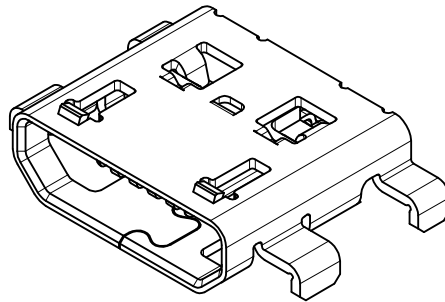
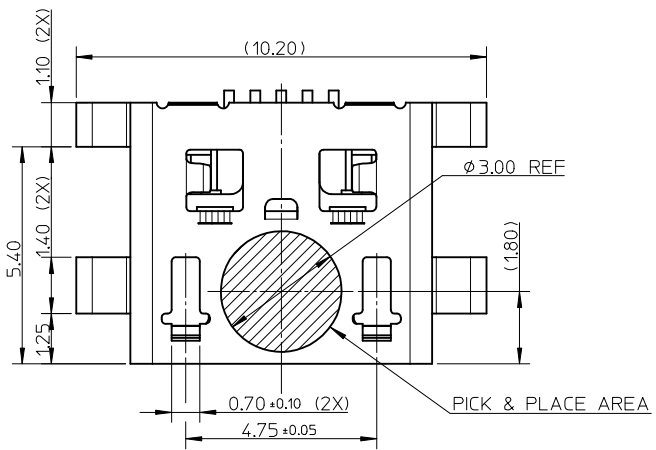

E

D

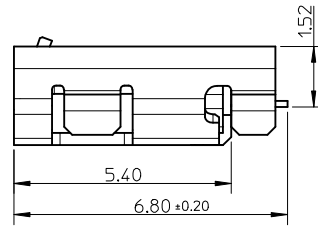
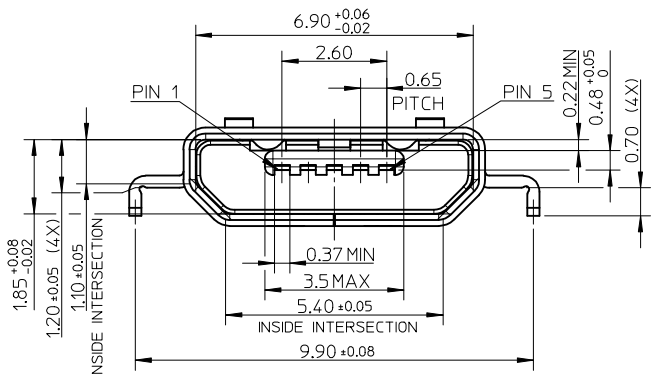

C

B

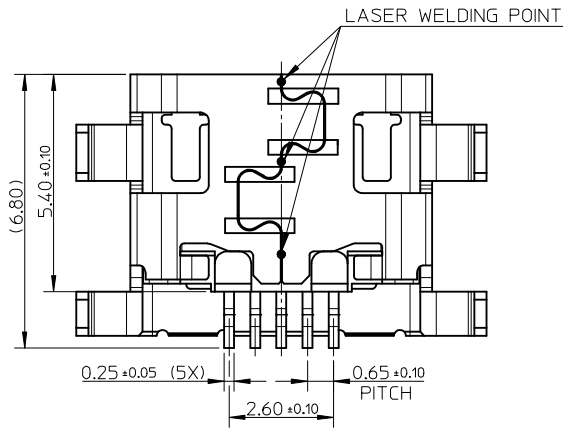

A

SEE SHEET 1 EC NO: SHZ013-0123 DRWN: XQZHANG CHKD: XQZHANG APPR: AYIN	REV DESCRIPTION	QUALITY SYMBOLS F _A =0 F _B =0 F _C =0	GENERAL TOLERANCES (UNLESS SPECIFIED)		DIMENSION STYLE MM ONLY	SCALE 1:1	DESIGN UNITS METRIC	THIRD ANGLE PROJECTION
			mm	INCH	DRAWN BY XQZHANG	DATE 2012/06/21	TITLE SALES DRAWING FOR USB MICRO-B, MID MOUNT FLANGELESS TYPE	
B	REV	DESCRIPTION	4 PLACES	± ---	± ---	CHECKED BY XQZHANG	DATE 2012/06/21	DOCUMENT NO. SD-105248-001
			3 PLACES	± ---	± ---	APPROVED BY AYIN	DATE 2012/10/11	
			2 PLACES	± 0.20	± ---	MATERIAL NO. 105248-1001	SHEET NO. 3 OF 3	
			1 PLACE	± 0.25	± ---	THIS DRAWING CONTAINS INFORMATION THAT IS PROPRIETARY TO MOLEX INCORPORATED AND SHOULD NOT BE USED WITHOUT WRITTEN PERMISSION		
			0 PLACE	± ---	± ---	ANGULAR ± 3°		
			DRAFT WHERE APPLICABLE MUST REMAIN WITHIN DIMENSIONS		SIZE A3			