



Chipsmall Limited consists of a professional team with an average of over 10 year of expertise in the distribution of electronic components. Based in Hongkong, we have already established firm and mutual-benefit business relationships with customers from,Europe,America and south Asia,supplying obsolete and hard-to-find components to meet their specific needs.

With the principle of “Quality Parts,Customers Priority,Honest Operation,and Considerate Service”,our business mainly focus on the distribution of electronic components. Line cards we deal with include Microchip,ALPS,ROHM,Xilinx,Pulse,ON,Everlight and Freescale. Main products comprise IC,Modules,Potentiometer,IC Socket,Relay,Connector.Our parts cover such applications as commercial,industrial, and automotives areas.

We are looking forward to setting up business relationship with you and hope to provide you with the best service and solution. Let us make a better world for our industry!



Contact us

Tel: +86-755-8981 8866 Fax: +86-755-8427 6832

Email & Skype: info@chipsmall.com Web: www.chipsmall.com

Address: A1208, Overseas Decoration Building, #122 Zhenhua RD., Futian, Shenzhen, China



REVISIONS			
REV	DESCRIPTION	DATE	APPROVED
01 ₄	REVISED	10/24/97	TWag

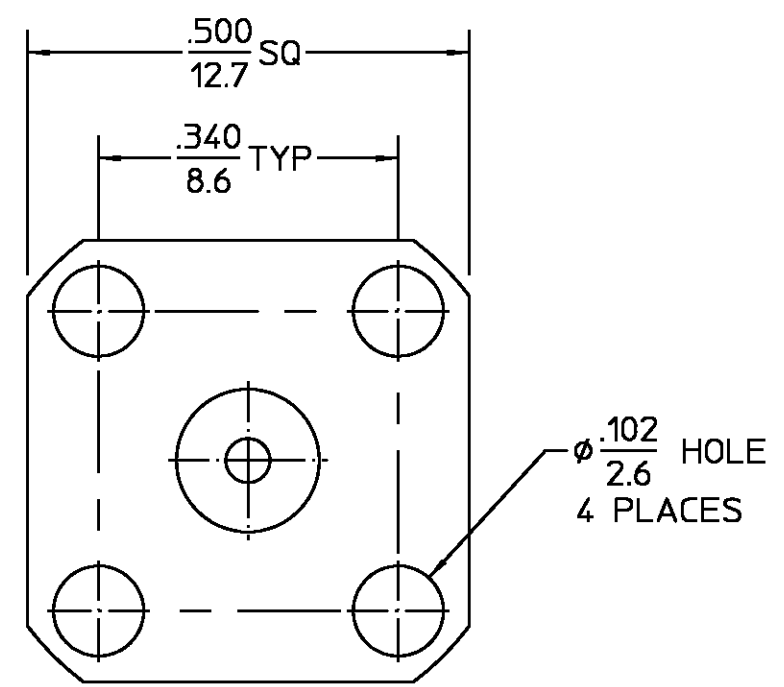
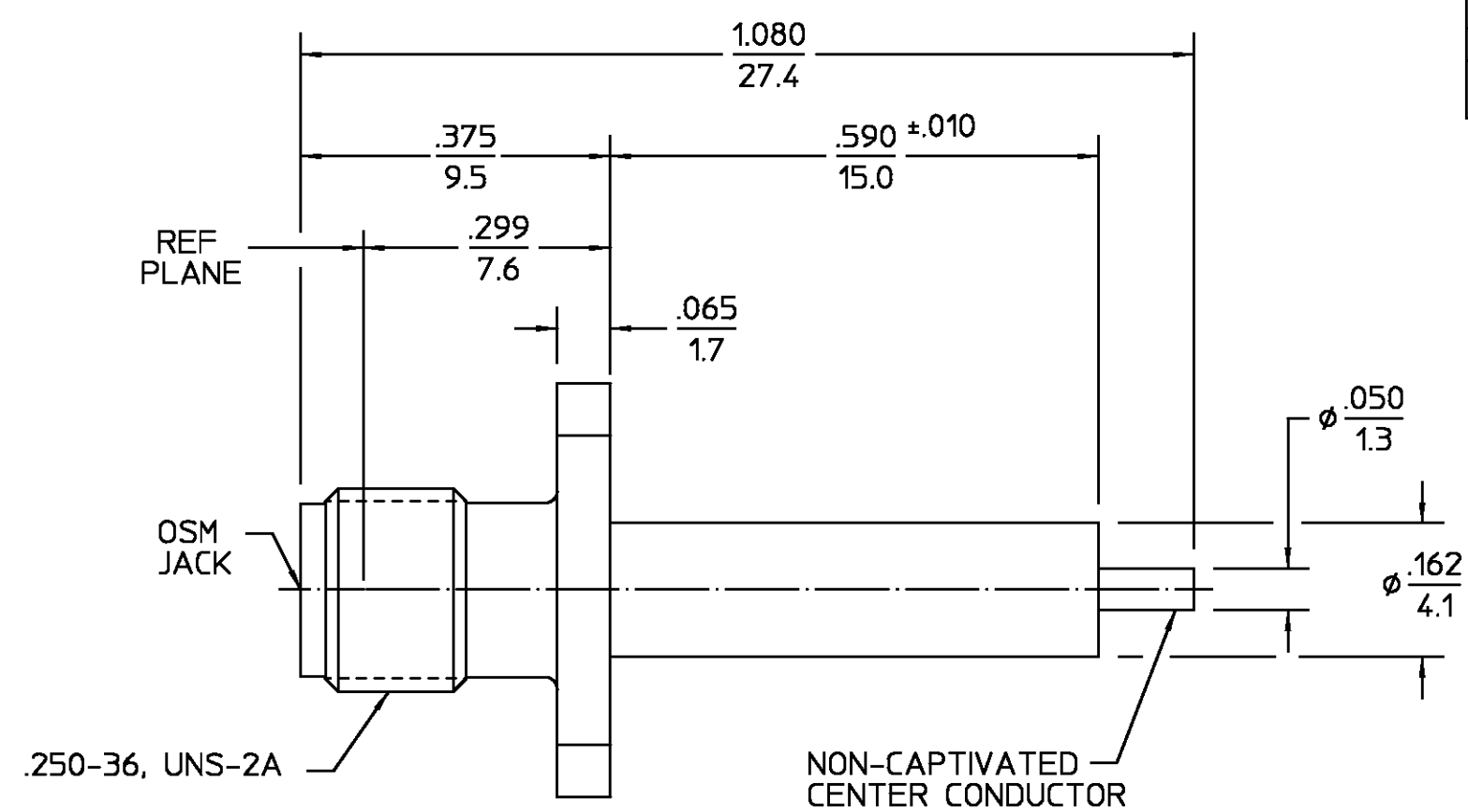

ELECTRICAL	MECHANICAL	ENVIRONMENTAL
Nominal Impedance (Ohms) <u>50</u>	Interface Dimensions MIL-STD-348, Fig. <u>310-2</u>	Temperature Rating <u>-65°C To 165°C</u>
Frequency Range (GHz) DC to <u>18</u>	Recommended Mating Torque <u>7-10 In-Lbs</u>	Vibration MIL-STD-202, Method 204, Condition D.
Volt Rating (VRMS MAX) @ Sea Level <u>335</u>	Mating Characteristics: Insertion (MAX Lbs) <u>2.0</u>	Shock MIL-STD-202, Method 213, Condition I.
VSWR <u>1.03 + .004f (GHz)</u>	Withdrawal (MIN Oz) <u>1.0</u>	Thermal Shock MIL-STD-202, Method 107, Condition B
Insertion Loss (dB MAX) <u>.03√f(GHz)</u>	Force to Engage and Disengage (In/Lbs MAX) <u>2.0</u>	Moisture Resistance MIL-STD-202, Method 106, Except Vibration
RF Leakage (dB MIN) <u>-[100-f(GHz)]</u>	Center Contact Captivation Axial (Lbs) <u>N/A</u>	Shall Be Omitted
Corona, 70,000 Ft (VRMS MIN) <u>250</u>	Radial (In/Oz) <u>N/A</u>	Corrosion - MIL-STD-202, Method 101, Condition B, 5% salt spray
Dielectric Withstanding Voltage (VRMS MIN) @ Sea Level <u>1,000</u>	Weight (Grams) <u>TBD</u>	
Contact Resistance (Milliohms MAX) Center Contact <u>2.0</u>		
Outer Contact <u>2.0</u>		
Cable to Housing <u>N/A</u>		
RF High Potential @ Sea Level (VRMS MIN @ 5 MHz) <u>670</u>		
I.R.(Megohms MIN) <u>10,000</u>		

COMPONENT	MATERIAL	FINISH
HOUSING	STAINLESS STEEL PER ASTM-A484 AND ASTM-A582, TYPE 303	GOLD PLATE PER MIL-G-45204
DIELECTRIC	TFE FLUOROCARBON PER ASTM-D-1457	N/A
CENTER CONTACT	BERYLLIUM COPPER PER ASTM-B 196, ALLOY C17300, CONDITION H	GOLD PLATE PER MIL-G-45204

UNLESS OTHERWISE SPECIFIED DIMENSIONS ARE IN INCHES TOLERANCE ON	DRAWN BY <u>BWC</u> DATE <u>6/6/67</u>	 AMP Incorporated 140 Fourth Avenue Waltham, MA 02451-7599
	FRACTIONAL DECIMAL ANGLES	
± 1/64 ±.005 ± °	CHECKED BY <u>PRB</u> DATE <u>7/5/68</u>	
	APPROVED BY <u>7/3/68</u>	

USE ASS'Y PROCEDURE	TITLE OSM 4 HOLE FLANGE MOUNT JACK RECEPTACLE STRAIGHT TERMINAL		
NO. AP. <u>N/A</u>	SIZE B	CODE IDENT NO. 26805	REV 01₄
	SCALE 5:1	PART NO. 2052-1200-00	
		SHEET 1 OF 1	

.XXX = in
XX.X = mm

CUSTOMER DRAWING

AMP PART # 1052517-1
SHEET 1 OF 1 REV A