



Chipsmall Limited consists of a professional team with an average of over 10 year of expertise in the distribution of electronic components. Based in Hongkong, we have already established firm and mutual-benefit business relationships with customers from,Europe,America and south Asia,supplying obsolete and hard-to-find components to meet their specific needs.

With the principle of "Quality Parts,Customers Priority,Honest Operation,and Considerate Service",our business mainly focus on the distribution of electronic components. Line cards we deal with include Microchip,ALPS,ROHM,Xilinx,Pulse,ON,Everlight and Freescale. Main products comprise IC,Modules,Potentiometer,IC Socket,Relay,Connector.Our parts cover such applications as commercial,industrial, and automotives areas.

We are looking forward to setting up business relationship with you and hope to provide you with the best service and solution. Let us make a better world for our industry!



Contact us

Tel: +86-755-8981 8866 Fax: +86-755-8427 6832

Email & Skype: info@chipsmall.com Web: www.chipsmall.com

Address: A1208, Overseas Decoration Building, #122 Zhenhua RD., Futian, Shenzhen, China



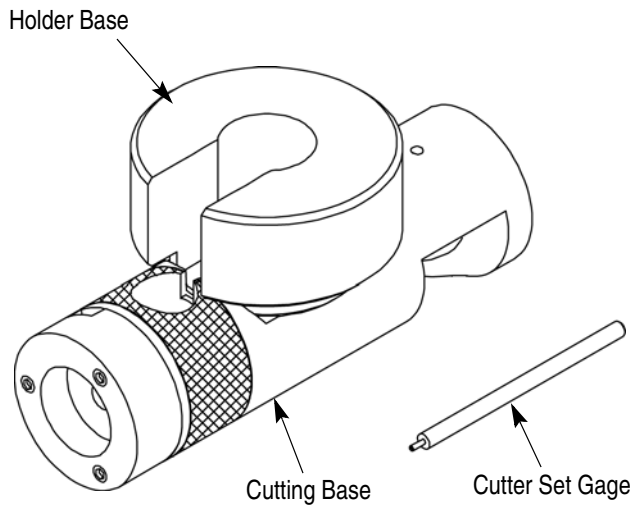

Figure 1

1. INTRODUCTION

(Non-adjustable) Hand Trim and Pointing Tool 1055824-1 was designed to cut the insulation on RG-405/U (0.085-inch) semi-rigid coaxial cable and “point” the center conductor of the stripped coaxial cable.

NOTE *Dimensions are in metric units [with U.S. customary units in brackets] unless otherwise designated.*

Refer to Section 5, REVISION SUMMARY for updates.

2. DESCRIPTION

This tool is shipped in kit form and consists of the holder base, the cutting base, and the cutter set gage. Refer to Figure 1 and Figure 4. The kit also contains two hex wrenches.

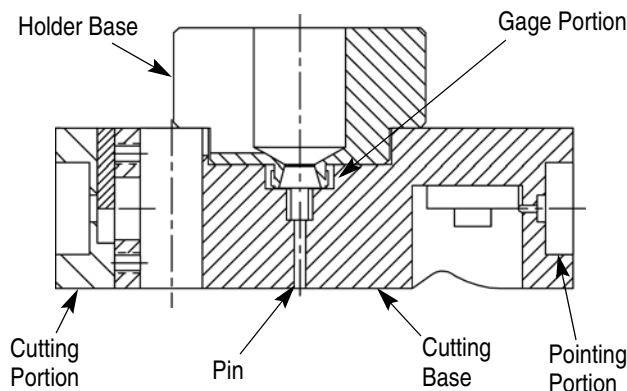

Figure 2

3. OPERATION

1. Seat the holder base onto the gage portion of the cutting base.
2. Insert the cable into the holder base until the cable makes contact with the pin of the gage. See Figure 2.
3. Firmly turn the holder base clockwise to tighten it.
4. Remove the holder base and insert it into the cutting portion of the cutter base.
5. Rotate the holder base clockwise and apply a light axial force to start the cut.
6. Continue rotating the cutting base until you can no longer feel resisting cutting force. (This indicates that the cutting/trimming portion of the operation is complete.)
7. Remove the cutting base from the holder base.

NOTE *The center conductor should now be exposed.*



8. Insert the holder base into the pointing portion of the cutting base.

9. With the cable still in the holder base, turn the cutting base clockwise four or five times while applying axial pressure.

10. Remove holder base from the pointing portion of the cutting base and re-insert it into the gage portion.

11. Turn the holder base approximately 1/2 turn counterclockwise to loosen it.

12. Remove the cable. The cable has now been trimmed and pointed to the dimensions shown in Figure 3.

NOTE *If the length of the cable center conductor is shorter than .065 inches for RG-405/U cable, the tool may not be able to adequately point the cable center conductor.*

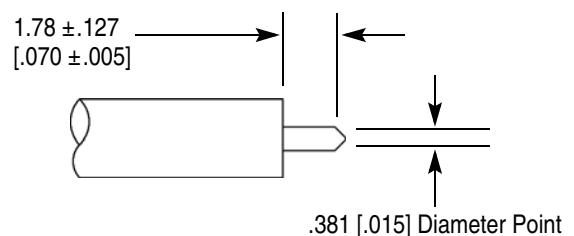

RG-405/U Cable

Figure 3

4. CUTTER ADJUSTMENT OR REPLACEMENT

4.1. Trim Length Adjustment

Use the set screw at the bottom of the cutting base assembly to adjust the trim length. Turn the set screw counterclockwise to increase the strip length.

4.2. Cutter Adjustment

The trim and pointing tool is already adjusted for most kinds of semi-rigid coaxial cable. However, if adjustment becomes necessary, proceed as follows:

1. Assemble the set gage in the holding base, as if it were a cable.
2. Loosen the .050-hex, set screw and retract the cutter slightly.
3. Put holder base/cutting gage assembly into the cutting portion of the cutting base.
4. Push the cutting blade into the cutter set gage. Then tighten the set screw.

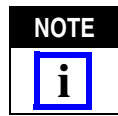

The slight changes in cutting depth are determined by how hard the cutter is pushed.

4.3. Cutter Replacement

If the pointing cutter becomes dull, remove the holding screw and remove the insert. Reposition the insert so a new cutting edge rests against the tool.

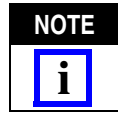

There are six cutting edges per insert.

5. REVISION SUMMARY

Since the previous version of this document, the following changes were made:

- Updated document to corporate requirements

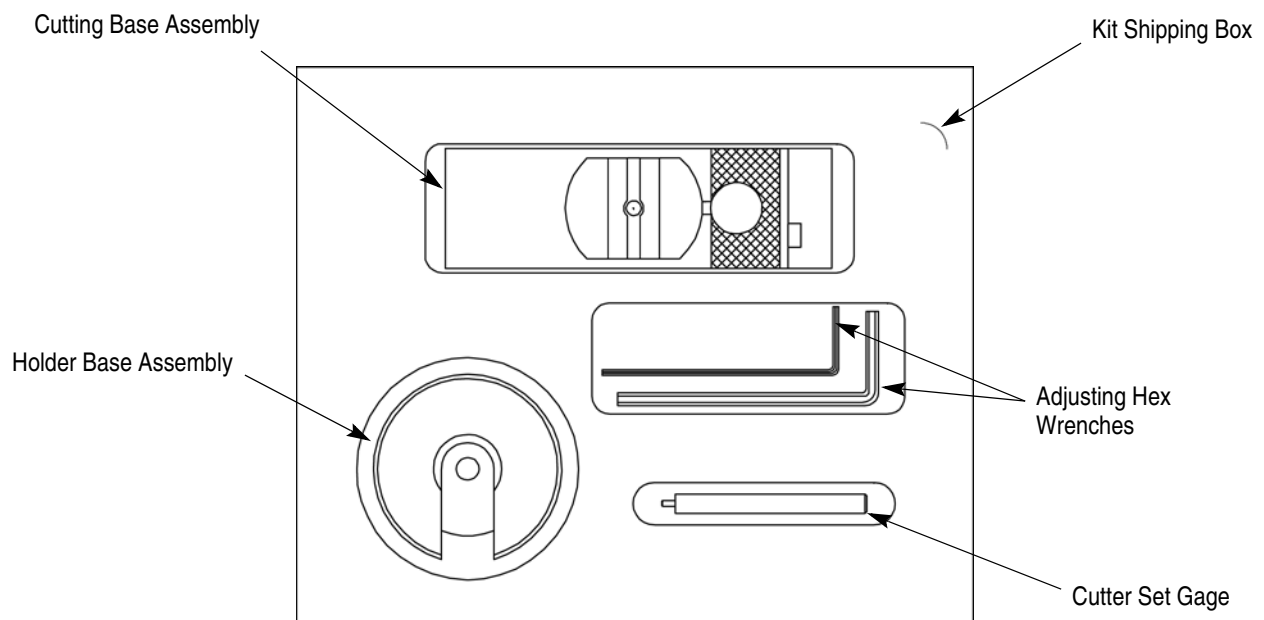

Figure 4