



Chipsmall Limited consists of a professional team with an average of over 10 year of expertise in the distribution of electronic components. Based in Hongkong, we have already established firm and mutual-benefit business relationships with customers from,Europe,America and south Asia,supplying obsolete and hard-to-find components to meet their specific needs.

With the principle of “Quality Parts,Customers Priority,Honest Operation,and Considerate Service”,our business mainly focus on the distribution of electronic components. Line cards we deal with include Microchip,ALPS,ROHM,Xilinx,Pulse,ON,Everlight and Freescale. Main products comprise IC,Modules,Potentiometer,IC Socket,Relay,Connector.Our parts cover such applications as commercial,industrial, and automotives areas.

We are looking forward to setting up business relationship with you and hope to provide you with the best service and solution. Let us make a better world for our industry!



Contact us

Tel: +86-755-8981 8866 Fax: +86-755-8427 6832

Email & Skype: info@chipsmall.com Web: www.chipsmall.com

Address: A1208, Overseas Decoration Building, #122 Zhenhua RD., Futian, Shenzhen, China



REVISIONS			
REV	DESCRIPTION	DATE	APPROVED
02 ₀	REVISED	10/16/95	DPG 10/19/95

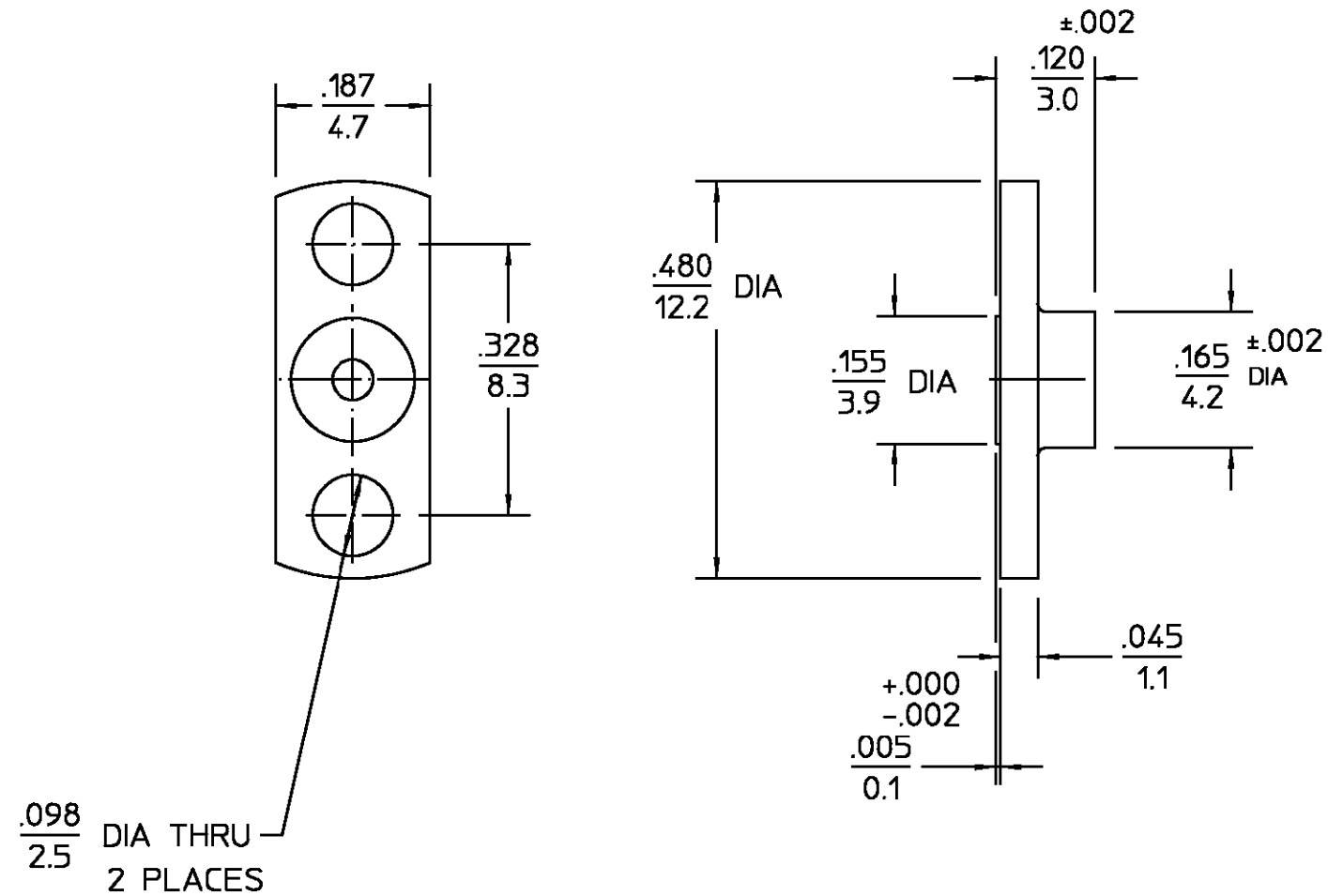

SHROUD	STAINLESS STEEL PER ASTM-A484 AND ASTM-A582, TYPE 303	PASSIVATE PER QQ-P-35
COMPONENT	MATERIAL	FINISH
UNLESS OTHERWISE SPECIFIED DIMENSIONS ARE IN INCHES TOLERANCE ON FRAC. DEC. ANGLES ± 1/64 ±.005 ± °	DRAWN BY <i>J. Davis</i> DATE 03/13/95	AMP Incorporated 140 Fourth Avenue Waltham, MA 02451-7599
	CHECKED BY APPD BY <i>J. Davis</i> DATE 03/13/95	
These drawings and specifications are the property of M/A-COM Incorporated and shall not be reproduced or copied or used in whole or in part as the basis for the manufacture or sale of item(s) without written permission.	USE ASS'Y PROCEDURE	TITLE OSMP SHROUD LIMITED DETENT
	408-04752 NO. AP. (29-006)	SIZE B CODE IDENT NO. 26805 2998-5028-02 REV 02 ₀
		SCALE 5:1 SHEET 1 OF 1

.XXX = in
XX.X = mm

CUSTOMER DRAWING

AMP PART # 1056729-1
SHEET 1 OF 1 REV A