



Chipsmall Limited consists of a professional team with an average of over 10 year of expertise in the distribution of electronic components. Based in Hongkong, we have already established firm and mutual-benefit business relationships with customers from,Europe,America and south Asia,supplying obsolete and hard-to-find components to meet their specific needs.

With the principle of “Quality Parts,Customers Priority,Honest Operation,and Considerate Service”,our business mainly focus on the distribution of electronic components. Line cards we deal with include Microchip,ALPS,ROHM,Xilinx,Pulse,ON,Everlight and Freescale. Main products comprise IC,Modules,Potentiometer,IC Socket,Relay,Connector.Our parts cover such applications as commercial,industrial, and automotives areas.

We are looking forward to setting up business relationship with you and hope to provide you with the best service and solution. Let us make a better world for our industry!



Contact us

Tel: +86-755-8981 8866 Fax: +86-755-8427 6832

Email & Skype: info@chipsmall.com Web: www.chipsmall.com

Address: A1208, Overseas Decoration Building, #122 Zhenhua RD., Futian, Shenzhen, China



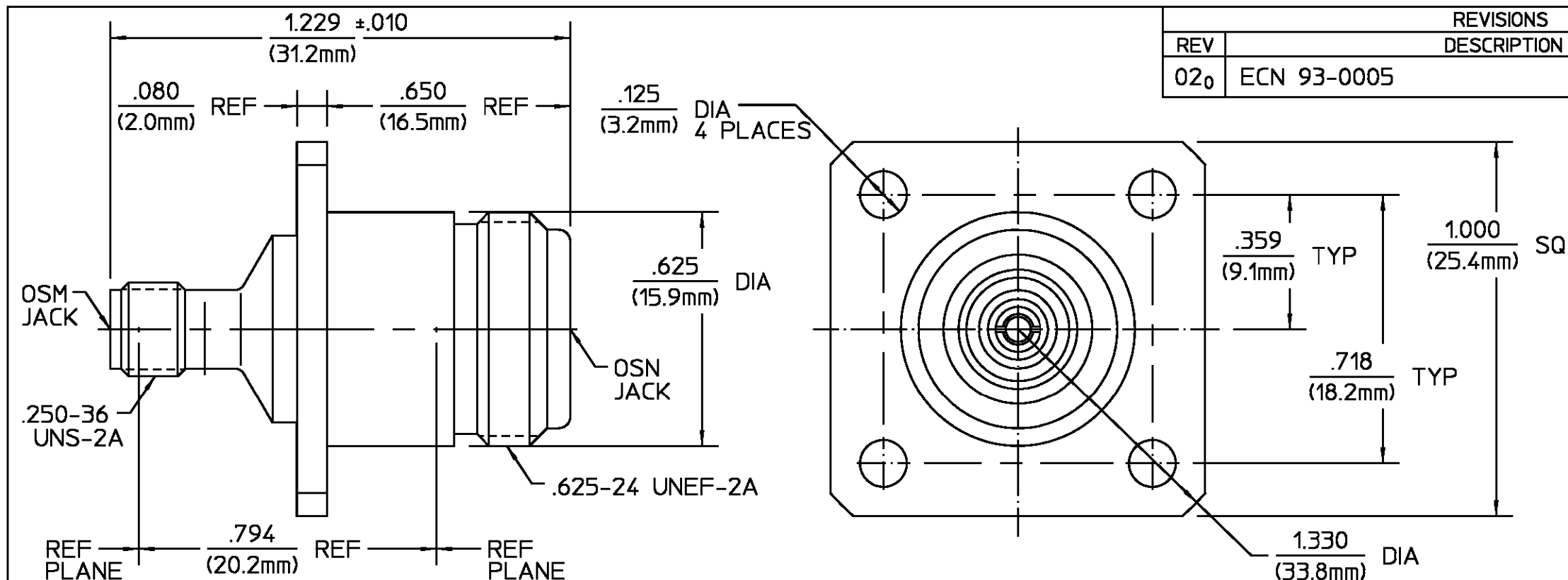

REVISIONS			
REV	DESCRIPTION	DATE	APPROVED
020	ECN 93-0005	2/18/93	<i>AD</i> DCm 2/22/93

ELECTRICAL	MECHANICAL	ENVIRONMENTAL
Nominal Impedance (Ohms) <u>50</u>	Interface Dimensions MIL-STD-348A, Fig. 310.2 (OSM) & 304.2 (N)	Temperature Rating <u>-65°C to +125°C</u>
Frequency Range (GHz) DC to <u>18</u>	Recommended Mating Torque <u>N/A</u>	Vibration MIL-STD-202, Method 204, Condition B
Volt Rating (VRMS MAX) @ Sea Level <u>335</u>	Mating Characteristics: OSM-Insertion (MAX lbs) <u>3.0</u>	Shock MIL-STD-202, Method 213, Condition I.
VSWR <u>DC - 12.4GHz: 1.06+.005f(GHz) MAX</u> <u>12.4 - 18.0GHz: .83+.023f(GHz) MAX</u>	Type N-Insertion (MAX lbs) <u>2.0</u>	Thermal Shock MIL-STD-202, Method 107, Condition C, except high temp shall be +115°C
Insertion Loss (dB MAX) <u>.18 @ 9GHz</u>	OSM-Withdrawal (MIN oz) <u>1.0</u>	Moisture Resistance MIL-STD-202, Method 106
RF Leakage (dB MIN) <u>-65 @ 2-3 GHz</u>	Type N-Withdrawal (MIN oz) <u>2.0</u>	Corrosion - MIL-STD-202, Method 101, Condition B, 5% salt spray
Corona, 70,000 Ft (VRMS MIN) <u>250</u>	Force to Engage and Disengage OSM (in-lbs MAX) <u>2.0</u>	
Dielectric Withstanding Voltage (VRMS MIN) @ Sea Level <u>1,000</u>	Type N (in-lbs MAX) <u>6.0</u>	
Contact Resistance (Milliohms MAX) Center Contact <u>4.1</u>	Center Contact Captivation Axial (lbs) <u>6.0</u>	
Outer Contact <u>2.2</u>	Radial (in-oz) <u>4.0</u>	
Cable to Housing <u>N/A</u>	Cable Retention Axial Force (lbs) <u>N/A</u>	
RF High Potential @ Sea Level (VRMS MIN @ 5 MHz) <u>1,000</u>	Torque (in-oz) <u>N/A</u>	
I.R.(Megohms MIN) <u>5,000</u>	Weight (Grams) <u>TBD</u>	

COMPONENT	MATERIAL	FINISH
HOUSING	STAINLESS STEEL PER ASTM-A484 AND ASTM-A582, TYPE 303	PASSIVATED
DIELECTRIC	TFE FLUOROCARBON PER ASTM-D-1457	N/A
CENTER CONTACT	BERYLLIUM COPPER PER ASTM B 196, ALLOY C17300, CONDITION H	GOLD PLATE PER MIL-G-45204 OVER NICKEL PLATE PER QQ-N-290

UNLESS OTHERWISE SPECIFIED DIMENSIONS ARE IN INCHES	DRAWN BY <u>CD</u> DATE <u>2-10-83</u>	AMP AMP Incorporated 140 Fourth Avenue Waltham, MA 02451-7599
TOLERANCE ON	CHECKED BY <u>WK</u> DATE <u>2-23-83</u>	
FRAC. DEC. ANGLES	APPD BY <u>DRG</u> DATE <u>3-3-83</u>	
± 1/64 ±.005 ± °	USE ASS'Y PROCEDURE	TITLE <u>OSN JACK TO OSM JACK ADAPTER</u>
These drawings and specifications are the property of Omni Spectra Incorporated and shall not be reproduced or copied or used in whole or in part as the basis for the manufacture or sale of item(s) without written permission.	NO. AP. <u>N/A</u>	SIZE <u>B</u> CODE IDENT NO. <u>26805</u> 3680-2242-00 REV <u>020</u>
	SCALE <u>4 : 1</u>	SHEET 1 OF 1

CUSTOMER DRAWING

AMP PART # 1058653-1
SHEET 1 OF 1 REV B
PER EC 0U20-0025-01