



Chipsmall Limited consists of a professional team with an average of over 10 year of expertise in the distribution of electronic components. Based in Hongkong, we have already established firm and mutual-benefit business relationships with customers from,Europe,America and south Asia,supplying obsolete and hard-to-find components to meet their specific needs.

With the principle of “Quality Parts,Customers Priority,Honest Operation,and Considerate Service”,our business mainly focus on the distribution of electronic components. Line cards we deal with include Microchip,ALPS,ROHM,Xilinx,Pulse,ON,Everlight and Freescale. Main products comprise IC,Modules,Potentiometer,IC Socket,Relay,Connector.Our parts cover such applications as commercial,industrial, and automotives areas.

We are looking forward to setting up business relationship with you and hope to provide you with the best service and solution. Let us make a better world for our industry!



## Contact us

Tel: +86-755-8981 8866 Fax: +86-755-8427 6832

Email & Skype: info@chipsmall.com Web: www.chipsmall.com

Address: A1208, Overseas Decoration Building, #122 Zhenhua RD., Futian, Shenzhen, China



# CUSTOMER DRAWING SHEET 2 & 3

©2011 CTP-COIL  
ALL DIMENSIONS IN mm

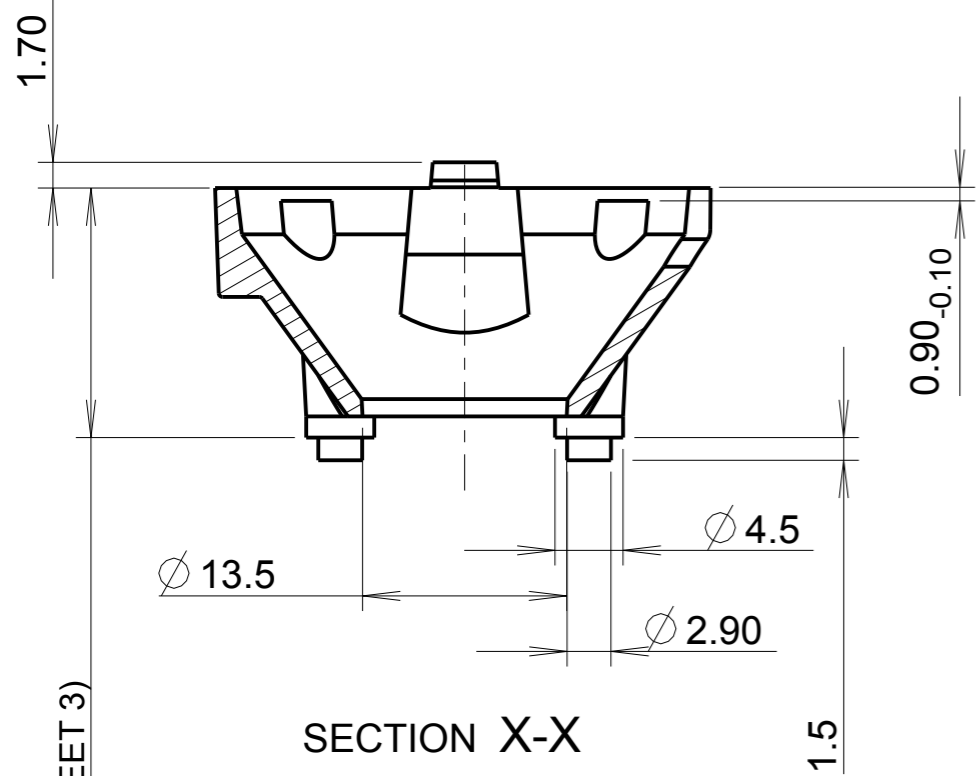
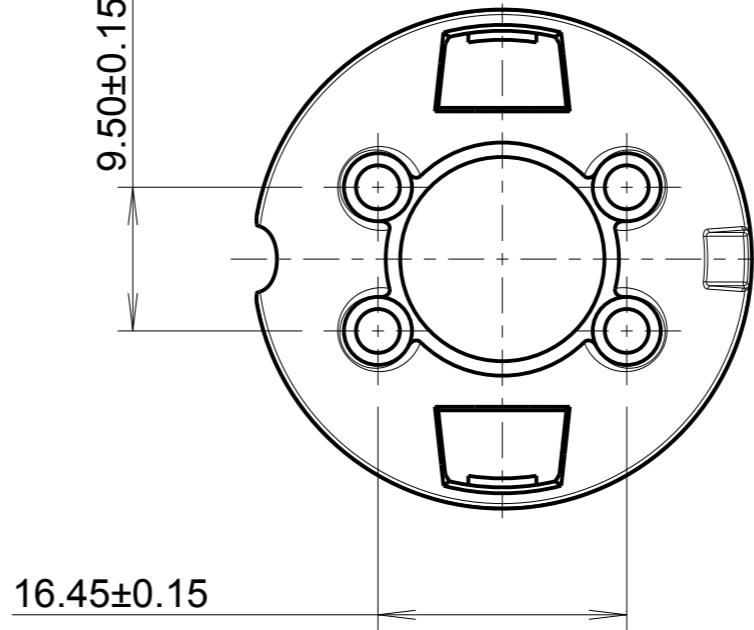
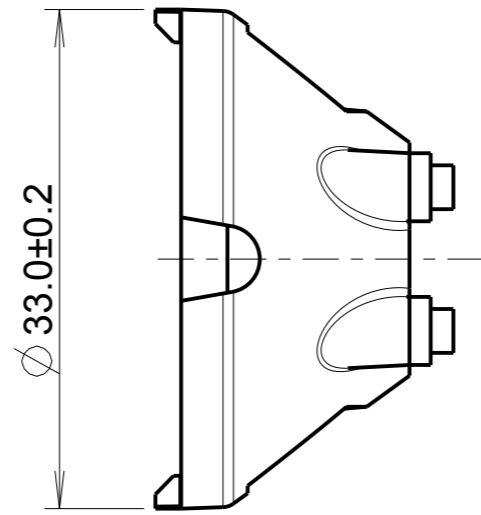
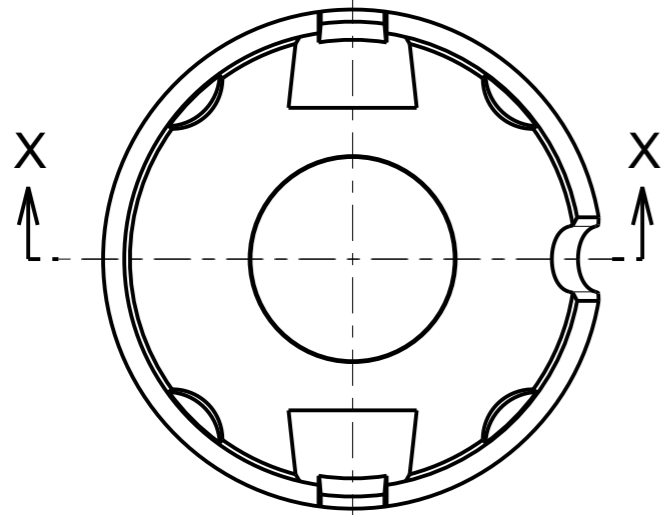
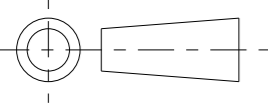

DIM. A (SEE SHEET 3)

SECTION X-X

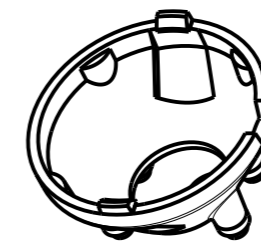

GENERAL 3D VIEW  
SCALE 1:1

NOTES:

1. MATERIAL: POLYCARBONATE
2. COLOUR: SEE TABLE ON SEPARATE SHEET

ISS.	DATE	E.C.N.	DESCRIPTION
1	11-Feb-09		FIRST ISSUE
1A	02-March-11		#10962 ADDED
1B	17-March-11	03/11/1290	NOTE CHANGE DIM CHANGE
1C	26-Sep-11	09/11/1309	PART NUMBERS ADDED



CARCLO TECHNICAL PLASTICS  
103 BUCKINGHAM AVE, SLOUGH  
SL1 4PF, ENGLAND  
TEL: +44 1753 575011 FAX: +44 1753 811359  
email: design@carclo-optics.com

GENERAL TOLERANCES (UNLESS STATED)

LINEAR		ANGULAR	
X	+/- 0.25	X	+/- 1°
X.X	+/- 0.1	X.X	+/- 0.5°
X.XX	+/- 0.05	X.XX	+/- 0.1°

CUSTOMER

TITLE

30.0 MM DIA OPTIC  
4 LEG HOLDER

DRAWN MKI DATE 11-Feb-09

CHK'D BB DATE 27-Sep-11

APP'D PW DATE 27-Sep-11

SCALE 2:1 COIL PART No. SEE TABLE ON SEPARATE SHEET 3

SIZE A3 COIL DRG. No. 60584 SHEET 2 OF 3



ISS.	DATE	E.C.N.	DESCRIPTION
1C	27-Sep-11	09/11/1309	PART NUMBERS ADDED

© 2011 CARCLO PLC  
ALL DIMENSIONS IN mm

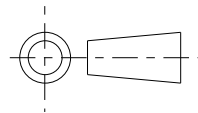

CARCLO TECHNICAL PLASTICS (SLOUGH)  
103 BUCKINGHAM AVE, SLOUGH  
SL1 4PF, ENGLAND  
TEL: +44 1753 575011 FAX: +44 1753 811359  
e-mail: design@carclo-optics.com

## CUSTOMER DRAWING SHEET 2 & 3

NOT ALL PARTS ARE AVAILABLE FROM STOCK.  
SOME PARTS ARE SPECIAL ORDER ONLY.

PLEASE CONTACT CARCLO FOR CURRENT AVAILABILITY

PARTS NUMBERS		
DIM A	BLACK HOLDERS	WHITE HOLDERS
15.3	10953	10954
15.5	10955	10956
15.7	10957	10958
15.9	10959	10960
16.1	10961	10962
16.3	10963	10964
16.5	10965	10966
16.7	10967	10968
16.9	10969	10970
17.1	10971	10972
17.3	10973	10974
17.5	10975	10976
17.7	10977	10978
17.9	10979	10980
18.1	10981	10982
18.3	10983	10984
18.5	10985	10986
18.7	10987	10988
18.9	10989	10990
19.1	10991	10992

### GENERAL TOLERANCES (UNLESS STATED)

LINEAR	ANGULAR
X +/- 0.25	X +/- 1°
X.X +/- 0.1	X.X +/- 0.5°
X.XX +/- 0.05	X.XX +/- 0.1°

CUSTOMER

CARCLO

TITLE

30.0MM DIA OPTIC  
4 LEG HOLDER

DRAWN

BB

DATE

27-Sep-11

CHK'D

FP

DATE

27-Sep-11

APP'D

PW

DATE

27-Sep-11

SCALE

2:1

COIL PART No.

SEE TABLE

SIZE

A4

COIL DRG. No.

60584

SHEET

3 OF 3