



Chipsmall Limited consists of a professional team with an average of over 10 year of expertise in the distribution of electronic components. Based in Hongkong, we have already established firm and mutual-benefit business relationships with customers from,Europe,America and south Asia,supplying obsolete and hard-to-find components to meet their specific needs.

With the principle of "Quality Parts,Customers Priority,Honest Operation,and Considerate Service",our business mainly focus on the distribution of electronic components. Line cards we deal with include Microchip,ALPS,ROHM,Xilinx,Pulse,ON,Everlight and Freescale. Main products comprise IC,Modules,Potentiometer,IC Socket,Relay,Connector.Our parts cover such applications as commercial,industrial, and automotives areas.

We are looking forward to setting up business relationship with you and hope to provide you with the best service and solution. Let us make a better world for our industry!



## Contact us

Tel: +86-755-8981 8866 Fax: +86-755-8427 6832

Email & Skype: info@chipsmall.com Web: www.chipsmall.com

Address: A1208, Overseas Decoration Building, #122 Zhenhua RD., Futian, Shenzhen, China



THIS DRAWING IS UNPUBLISHED. RELEASED FOR PUBLICATION 2006  
 © COPYRIGHT 2000 BY TYCO ELECTRONICS CORPORATION. ALL RIGHTS RESERVED.

LOC	DIST	REVISIONS				
P	LTR	DESCRIPTION	DATE	DWN	APVD	
A1	-	C1	ECR-10-024592	09DEC2010	GW	MH

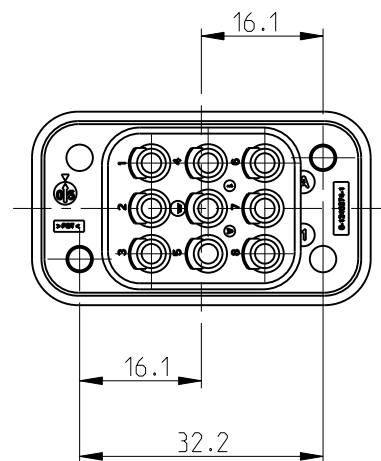

Contact arrangement  
view from termination side

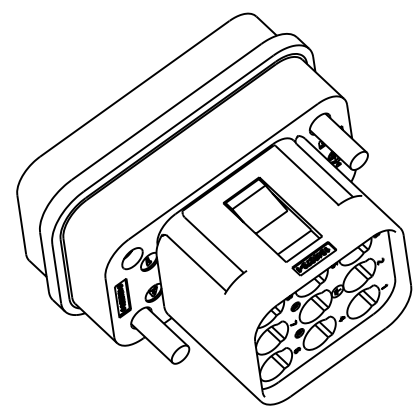
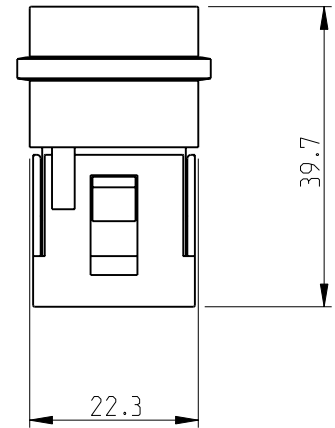
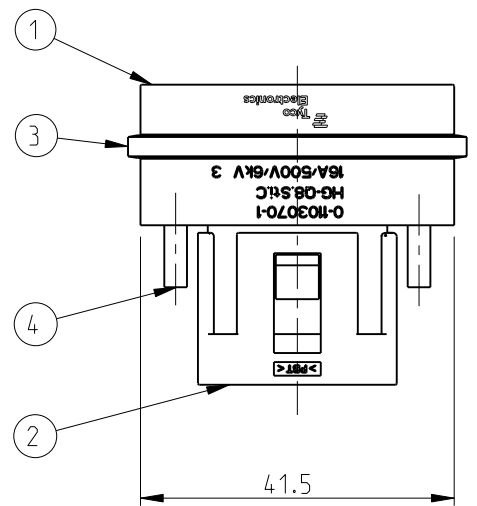
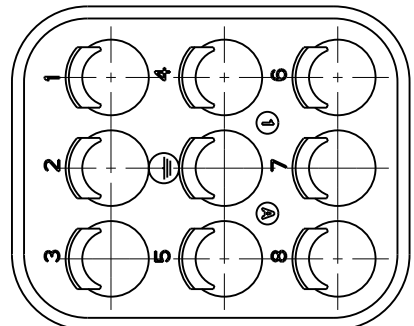

PN 0-1 as shown

QTY.	DESCRIPTION	MATERIAL	SURFACE	NOTE	ITEM
2	Screw for plastics	Steel	Zinc plated	EJOT DELTA PT 3X10-Z	4
1	Seals	NBR 72	Natural	CONDUCTIVE	3
1	Cover	Crastin	Light Grey	-	2
1	Male insert	Valox	Light Grey	-	1

PARTS LIST

DIMENSIONS: mm 		TOLERANCES UNLESS OTHERWISE SPECIFIED: 0 PLC ± 1 PLC ± 2 PLC ± 3 PLC ± 4 PLC ± ANGLES ±1° FINISH 		DWN M.Schweiger 05.10.04 CHK M.Schweiger 05.10.04 APVD T.Schnurpfeil 05.10.04 PRODUCT SPEC 108-74050 APPLICATION SPEC 114-74050 WEIGHT 0.016 KG CUSTOMER DRAWING		Tyco Electronics AMP GmbH D - 53757, Sankt Augustin, Germany NAME Cover Pin insert HG-Q8.Sti.C SIZE A3 CAGE CODE 00779 DRAWING NO. C=1103070 RESTRICTED TO - SCALE 2:1 SHEET 1 OF 1 REV C1	
-----------------------	--	---	--	--	--	---	--