



Chipsmall Limited consists of a professional team with an average of over 10 year of expertise in the distribution of electronic components. Based in Hongkong, we have already established firm and mutual-benefit business relationships with customers from,Europe,America and south Asia,supplying obsolete and hard-to-find components to meet their specific needs.

With the principle of “Quality Parts,Customers Priority,Honest Operation,and Considerate Service”,our business mainly focus on the distribution of electronic components. Line cards we deal with include Microchip,ALPS,ROHM,Xilinx,Pulse,ON,Everlight and Freescale. Main products comprise IC,Modules,Potentiometer,IC Socket,Relay,Connector.Our parts cover such applications as commercial,industrial, and automotives areas.

We are looking forward to setting up business relationship with you and hope to provide you with the best service and solution. Let us make a better world for our industry!



Contact us

Tel: +86-755-8981 8866 Fax: +86-755-8427 6832

Email & Skype: info@chipsmall.com Web: www.chipsmall.com

Address: A1208, Overseas Decoration Building, #122 Zhenhua RD., Futian, Shenzhen, China



Contact arrangement view from connecting side

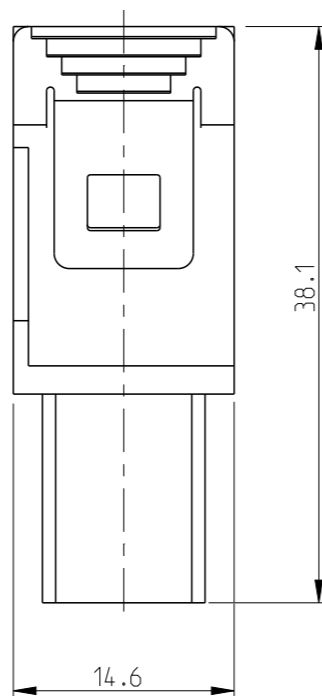
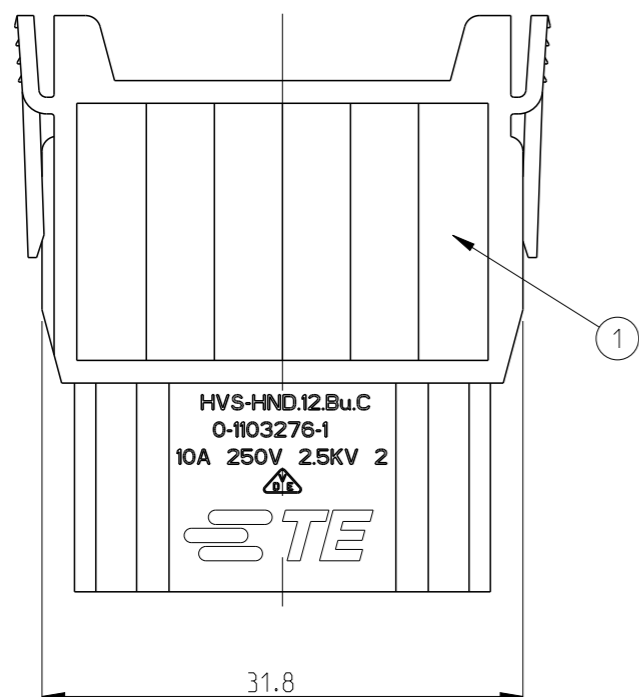
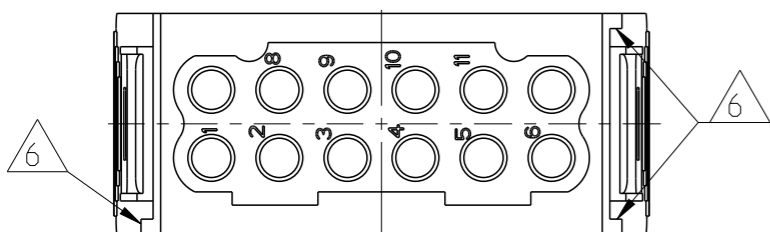

Contact arrangement view from termination side

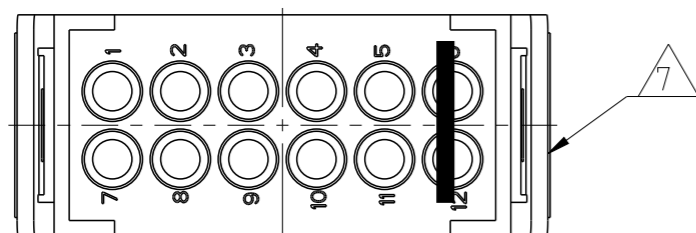

NOTES

- 1 SUITABLE CRIMP CONTACTS: SERIES HN.D
CUSTOMER DRAWING: 1105051
OUTER DIMENSIONS OF INSULATION: MAX. Ø4mm
- 2 SUITABLE MODULE FIXING FRAME: SERIES HVS SIZE 3 TO 8
CUSTOMER DRAWING: 1103250
- 3 SUITABLE INSERTION TOOL:
CUSTOMER DRAWING: 1102855
- 4 SUITABLE EXTRACTION TOOL:
CUSTOMER DRAWING: 1102855
- 5 STANDARDS:
DIN EN 61984; DIN EN 60664-1
- 6 POLARIZATION RIPS
- 7 MARKING OF POLARIZATION ACCORDING TO MARKING OF MODULE FRAME
- 8 PACKAGING:
10 PIECES IN A CARTON

PN 0-1 As Shown

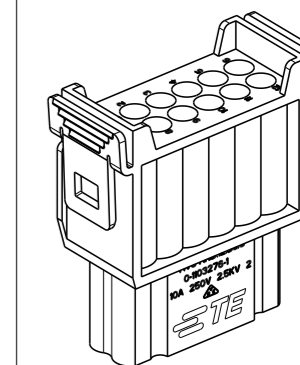

1:1

QTY	DESCRIPTION	MATERIAL	COLOR	ITEM NO
1	FEMALE INSERT	PBT-GF10	LIGHT GREY	1
PN 0-1 / HVS-HND.12.BU.C				

PN 0-1 AS SHOWN

THIS DRAWING IS A CONTROLLED DOCUMENT.		DWN	20.2.2006		STE TE Connectivity
DIMENSIONS: mm		CHK	20.2.2006		
TOLERANCES UNLESS OTHERWISE SPECIFIED: ISO 8075 DIN ISO 2768 mH-E DIN 16901-120		APVD	20.2.2006		
0 PLC ± 1 PLC ± 2 PLC ± 3 PLC ± 4 PLC ± ANGLES ±		PRODUCT SPEC	108-74083		
MATERIAL		FINISH	114-74085		NAME
9		10		FEMALE INSERT HVS-HND.12.BU.C	
CUSTOMER DRAWING			WEIGHT	RESTRICTED TO	
SCALE 2:1			SHEET 1 OF 1	REV C	