

Chipsmall Limited consists of a professional team with an average of over 10 year of expertise in the distribution of electronic components. Based in Hongkong, we have already established firm and mutual-benefit business relationships with customers from,Europe,America and south Asia,supplying obsolete and hard-to-find components to meet their specific needs.

With the principle of “Quality Parts,Customers Priority,Honest Operation,and Considerate Service”,our business mainly focus on the distribution of electronic components. Line cards we deal with include Microchip,ALPS,ROHM,Xilinx,Pulse,ON,Everlight and Freescale. Main products comprise IC,Modules,Potentiometer,IC Socket,Relay,Connector.Our parts cover such applications as commercial,industrial, and automotives areas.

We are looking forward to setting up business relationship with you and hope to provide you with the best service and solution. Let us make a better world for our industry!



Contact us

Tel: +86-755-8981 8866 Fax: +86-755-8427 6832

Email & Skype: info@chipsmall.com Web: www.chipsmall.com

Address: A1208, Overseas Decoration Building, #122 Zhenhua RD., Futian, Shenzhen, China

RPLIDAR A2

Low Cost 360 Degree Laser Range Scanner

Introduction and Datasheet

Model: A2M5

A2M6

OPTMAG

4K

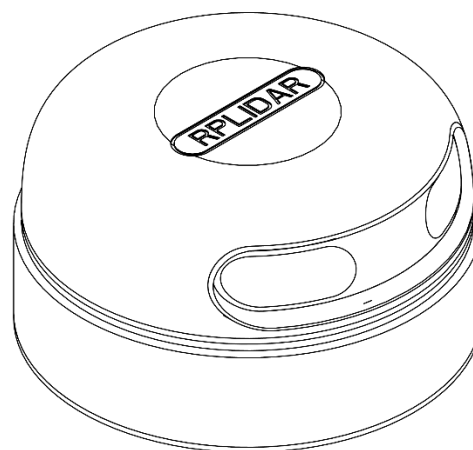

CONTENTS	1
INTRODUCTION	3
SYSTEM CONNECTION	4
MECHANISM.....	5
SAFETY AND SCOPE	6
DATA OUTPUT.....	6
HIGH SPEED SAMPLING PROTOCOL AND COMPATIBILITY	7
APPLICATION SCENARIOS.....	8
SPECIFICATION	9
MEASUREMENT PERFORMANCE	9
LASER POWER SPECIFICATION.....	9
OPTICAL WINDOW.....	10
COORDINATE SYSTEM DEFINITION OF SCANNING DATA	10
COMMUNICATION INTERFACE	11
MISC.....	14
SELF-PROTECTION AND STATUS DETECTION	15
SDK AND SUPPORT	16
MECHANICAL DIMENSIONS	17
REVISION HISTORY	18
APPENDIX	19
IMAGE AND TABLE INDEX	19



The RPLIDAR A2 is the next generation low cost 360 degree 2D laser scanner (LIDAR) solution developed by SLAMTEC. It can take up to 4000 samples of laser ranging per second with high rotation speed. And equipped with SLAMTEC patented OPTMAG technology, it breakouts the life limitation of traditional LIDAR system so as to work stably for a long time.

RPLIDAR A2M5/A2M6 is the enhanced version of 2D laser range scanner(LIDAR). The system can perform 2D 360-degree scan within a 16-meter range. The generated 2D point cloud data can be used in mapping, localization and object/environment modeling.

The typical scanning frequency of the RPLIDAR A2 is 10hz (600rpm). Under this condition, the angular resolution will be 0.9° . And the actual scanning frequency can be freely adjusted within the 5-15hz range according to the requirements of users.

The RPLIDAR A2 adopts the low cost laser triangulation measurement system developed by SLAMTEC, which makes the RPLIDAR A2 has excellent performance in all kinds of indoor environment and outdoor environment without direct sunlight exposure. Meanwhile, before leaving the factory, every RPLIDAR A2 has

passed the strict testing to ensure the laser output power meet the standards of FDA Class I.

System connection

The RPLIDAR A2 consists of a range scanner core and the mechanical powering part which makes the core rotate at a high speed. When it functions normally, the scanner will rotate and scan clockwise. And users can get the range scan data via the communication interface of the RPLIDAR and control the start, stop and rotating speed of the rotate motor via PWM.

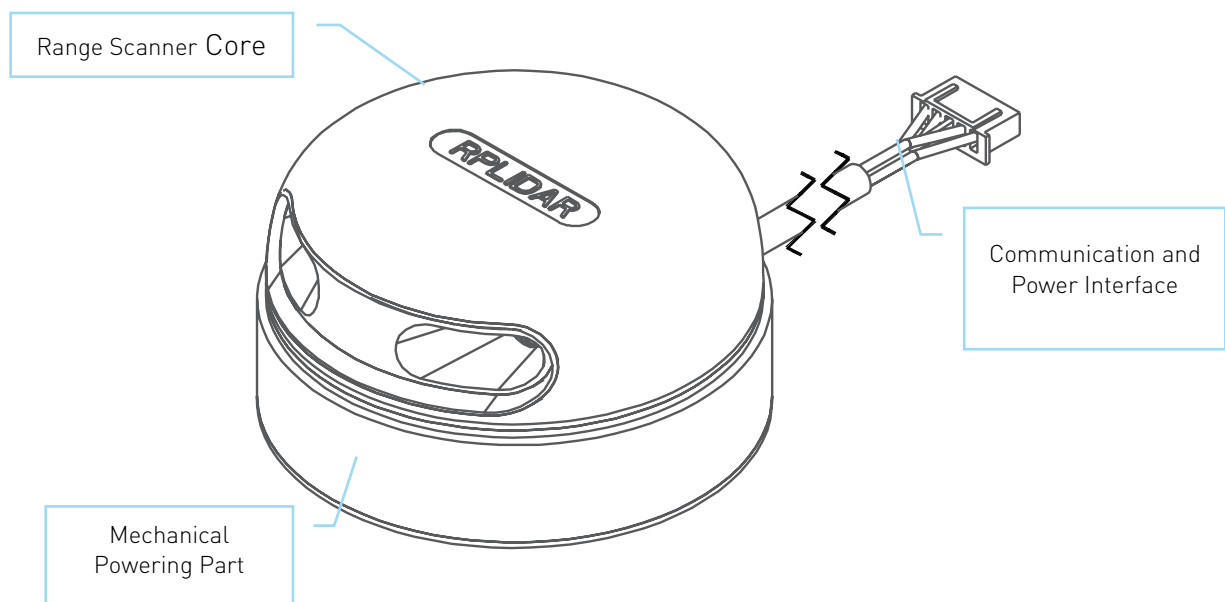

Figure 1-1 RPLIDAR System Composition

The RPLIDAR A2 comes with a rotation speed detection and adaptive system. The system will adjust the angular resolution automatically according to the actual rotating speed. And there is no need to provide complicated power system for RPLIDAR. In this way, the simple power supply schema saves the BOM cost. If the actual speed of the RPLIDAR is required, the host system can get the related data via communication interface.

The detailed specification about power and communication interface can be found in the following sections.

Mechanism

The RPLIDAR A2 is based on laser triangulation ranging principle and adopts the high-speed vision acquisition and processing hardware developed by SLAMTEC. The system ranges more than 4000 times per second.

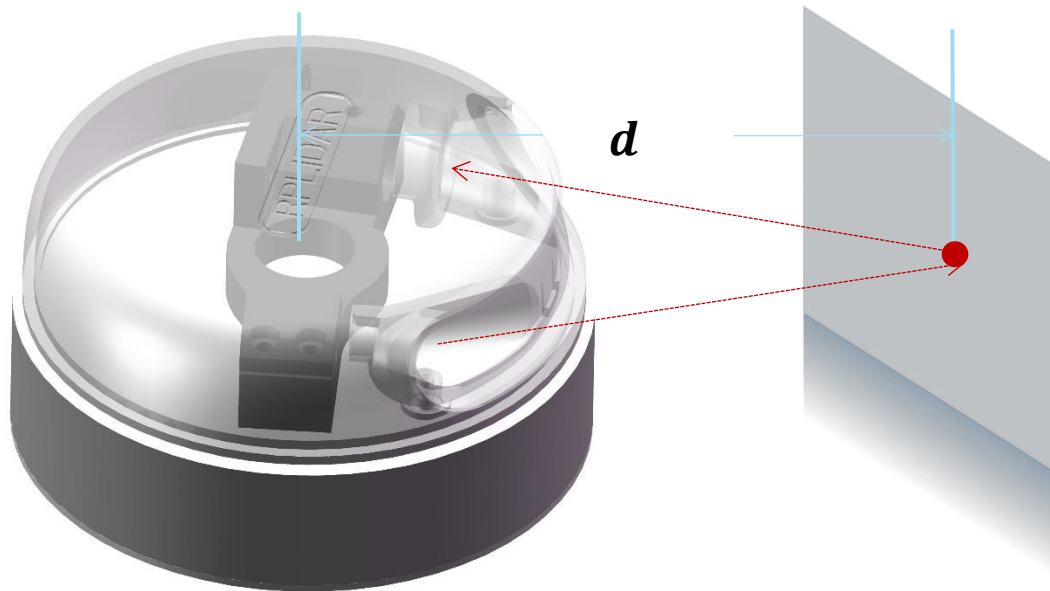
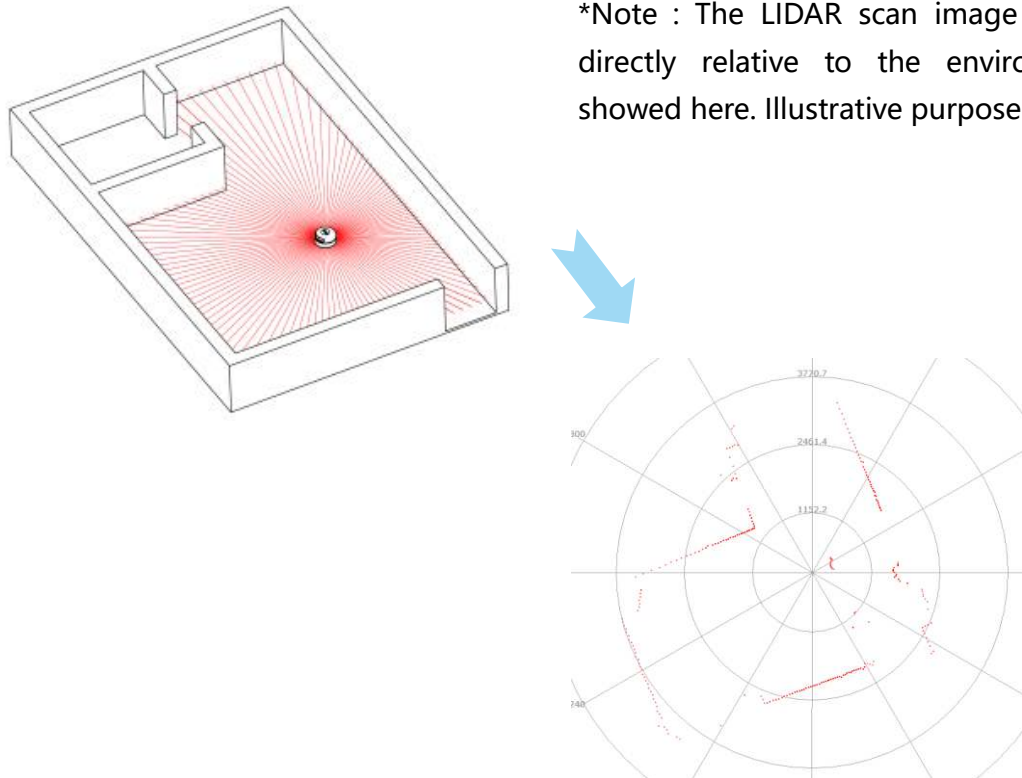

Figure 1-2 The RPLIDAR Working Schematic

During every ranging process, the RPLIDAR emits modulated infrared laser signal and the laser signal is then reflected by the object to be detected. The returning signal is then sampled by vision acquisition system in RPLIDAR and the DSP embedded in RPLIDAR starts processing the sample data and outputs distance value and angle value between object and RPLIDAR via communication interface.

When drove by the motor system, the range scanner core will rotate clockwise and perform the 360-degree scan for the current environment.



*Note : The LIDAR scan image is not directly relative to the environment showed here. Illustrative purpose only.

Figure 1-3 The Obtained Environment Map from RPLIDAR Scanning

Safety and Scope

The RPLIDAR A2 system uses a low power infrared laser as its light source, and drives it by using modulated pulse. The laser emits light in a very short time frame which can ensure its safety to human and pets, and it reaches Class I laser safety standard.



Class I

The modulated laser can effectively avoid the interference from ambient light and sunlight during ranging scanning process, which makes RPLIDAR work excellent in all kinds of indoor environment and outdoor environment without sunlight.

Data Output

During the working process, the RPLIDAR will output the sampling data via the communication interface. And each sample point data contains the information in the following table. If you need detailed data format and communication protocol, please contact SLAMTEC.

Data Type	Unit	Description
Distance	mm	Current measured distance value between the rotating core of the RPLIDAR and the sampling point
Heading	degree	Current heading angle of the measurement
Start Flag	(Bool)	Flag of a new scan
Checksum		The Checksum of RPLIDAR return data

Figure 1-4 The RPLIDAR Sample Point Data Information

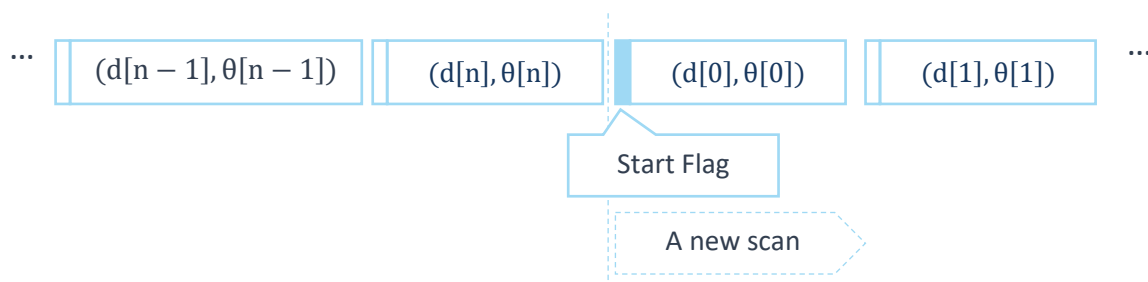

Figure 1-5 The RPLIDAR Sample Point Data Frames

The RPLIDAR outputs sampling data continuously and it contains the sample point data frames in the above figure. Host systems can configure output format and stop RPLIDAR by sending stop command. For detailed operations please contact SLAMTEC.

High Speed Sampling Protocol and Compatibility

The RPLIDAR A2 adopts the newly extended high speed sampling protocol for outputting the 4000 times per second laser range scan data. Users are required to update the matched SDK or modify the original driver and use the new protocol to use the 4000 times per second mode of RPLIDAR A2. Please check the related protocol documents for details.

The RPLIDAR A2 is compatible with all the communication protocols of previous versions. Users can directly replace the previous RPLIDAR with RPLIDAR A2 and use it in the original system. But in this scenario, the RPLIDAR A2 will work in compatible mode and the system will take range 2000 times per second.

Application Scenarios

The RPLIDAR can be used in the following application scenarios:

- General robot navigation and localization
- Environment scanning and 3D re-modeling
- Service robot or industrial robot working for long hours
- Home service /cleaning robot navigation and localization
- General simultaneous localization and mapping (SLAM)
- Smart toy's localization and obstacle avoidance

Measurement Performance

- For Model A2M5/A2M6 Only

Item	Unit	Min	Typical	Max	Comments
Distance Range	Meter(m)	0.2	-	16	Based on white objects with 70% reflectivity
Angular Range	Degree	-	0-360	-	-
Distance Resolution	mm	-	<0.5 <1% of the distance	-	<1.5 meters All distance range*
Angular Resolution	Degree	0.45	0.9	1.35	10Hz scan rate
Sample Duration	Millisecond(ms)	-	0.25	-	-
Sample Frequency	Hz	2000	4000	4100	
Scan Rate	Hz	5	10	15	The rate is for a round of scan. The typical value is measured when RPLIDAR takes 400 samples per scan

Figure 2-1 RPLIDAR Performance

Note: the triangulation range system resolution changes along with distance.

Laser Power Specification

- For Model A2M5/A2M6 Only

Item	Unit	Min	Typical	Max	Comments
Laser wavelength	Nanometer(nm)	775	785	795	Infrared Light Band
Laser power	Milliwatt (mW)	-	3	5	Peak power
Pulse length	Microsecond(us)	60	87	90	-
Laser Safety Class	-	-	FDA Class I	-	-

Figure 2-2 RPLIDAR Optical Specification

Note: the laser power listed above is the peak power and the actual average power is much lower than the value.

Optical Window

To make the RPLIDAR A2 working normally, please ensure proper space to be left for its emitting and receiving laser lights when designing the host system. The obscuring of the host system for the ranging window will impact the performance and resolution of RPLIDAR A2. If you need cover the RPLIDAR A2 with translucent materials or have other special needs, please contact SLAMTEC about the feasibility.

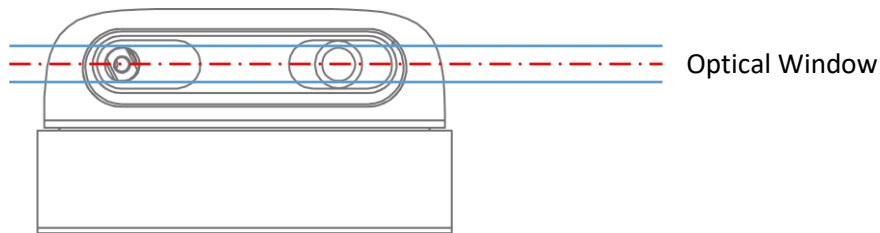

Figure 2-3 RPLIDAR Optical Window

You can check the Mechanical Dimensions chapter for detailed window dimensions.

Coordinate System Definition of Scanning Data

The RPLIDAR A2 adopts coordinate system of the left hand. The dead ahead of the sensors is the x axis of the coordinate system; the origin is the rotating center of the range scanner core. The rotation angle increases as rotating clockwise. The detailed definition is shown in the following figure:

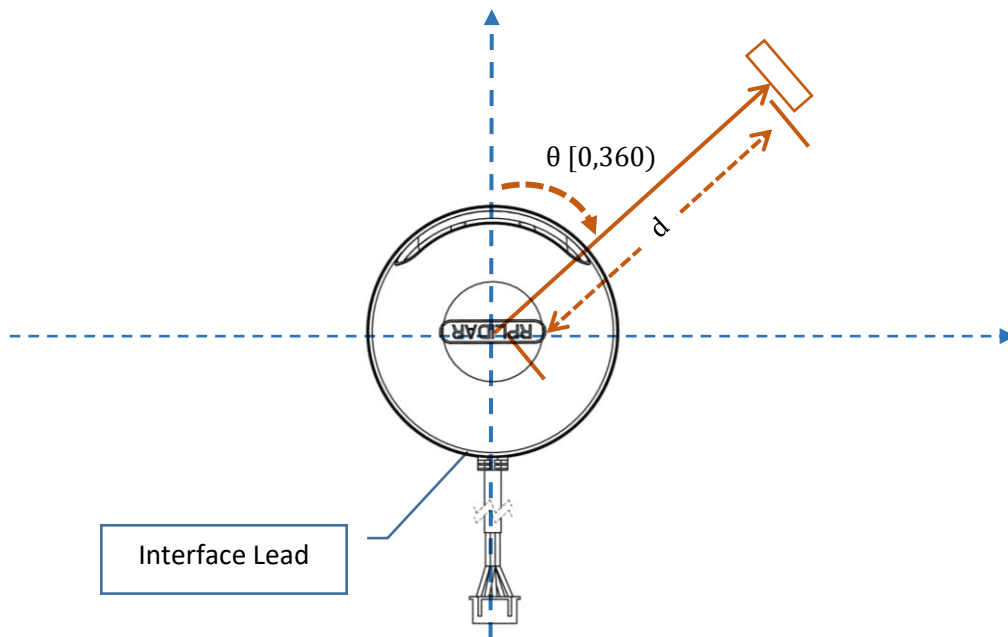

Figure 2-4 RPLIDAR Scanning Data Coordinate System Definition

Communication interface

The RPLIDAR A2 uses separate 5V DC power for powering the range scanner core and the motor system. And the standard RPLIDAR A2 uses XH2.54-5P male socket. Detailed interface definition is shown in the following figure:

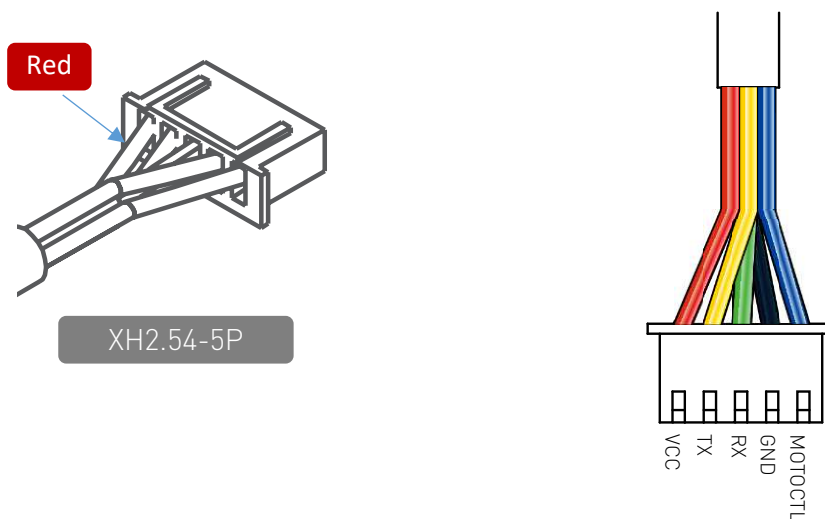

Figure 2-5 RPLIDAR Power Interface Definition

Color	Signal Name	Type	Description	Min	Typical	Max
Red	VCC	Power	Total Power	4.9V	5V	5.5V
Yellow	TX	Output	Serial port output of the scanner core	0V	3.3V	3.5V
Green	RX	Input	Serial port input of the scanner core	0V	3.3V	3.5V
Black	GND	Power	GND	0V	0V	0V
Blue	MOTOCTL	Input	Scan motor /PWM Control Signal (active high, internal pull down)	0V	3.3V	5V

Figure 2-6 RPLIDAR External Interface Signal Definition

Power Supply Interface

RPLIDAR A2 takes the only external power to power the range scanner core and the motor system which make the core rotate. To make the RPLIDAR A2 work normally, the host system needs to ensure the output of the power and meet its requirements of the power supply ripple.

● For Model A2M5/A2M6 Only

Item	Unit	Min	Typical	Max	Remark
Power Voltage	V	4.9	5	5.5	If the voltage exceeds the max value, it may damage the core
Power Voltage Ripple	mV	-	20	50	High ripple may cause the core working failure.
System Start Current	mA	-	1200	1500	The system startup requires relatively higher current.
Power Current	mA	TBD	200	220	5V Power , power off
		TBD	450	600	5V Power , power on

Figure 2-7 RPLIDAR Power Supply Specification

Data communication interface

The RPLIDAR A2 takes the 3.3V-TTL serial port (UART) as the communication interface. The table below shows the transmission speed and the protocol standard.

Item	Unit	Min	Typical	Max	Comments
Band rate	bps	-	115200	-	-
Working mode	-	-	8N1	-	8n1
Output high voltage	Volt (V)	2.9	-	3.5	Logic High
Output low voltage	Volt (V)	-	-	0.4	Logic Low
Input high voltage	Volt (V)	1.6*	-	3.5	Logic High
Input low voltage	Volt (V)	-0.3	-	0.4	Logic Low

Figure 2-8 RPLIDAR Serial Port Interface Specifications

Note: the RX input signal of A2M5/A2M6 is current control type. In order to ensure the reliable signal identification inside the system, the actual control node voltage of this pin will not be lower than 1.6v.

Scanner Motor Control

The RPLIDAR A2 is embedded with a motor driver which has speed tuning feature. Users can control the start, the stop and the rotating speed for the motor via MOTOCTL in the interface. MOTOCTL can be supplied using PWM signal with special frequency and duty cycle, and in this mode, the rotating speed is decided by the duty cycle of the input MOTOCTL PWM Signal.

The following table describes the requirement for the input PWM signal of MOTOCTL:

Item	Unit	Min	Typical	Max	Comments
High level voltage	V	3.0V	3.3V	5V	-
PWM frequency	Hz	24,500	25,000	25,500	Square Signal
Duty cycle range	-	0%	60%*	100%	Typical value is the duty cycle of high pulse width when the scanner frequency is at 10hz

Figure 2-9 RPLIDA Specification for PWM Signal of MOTOCTL

Note: the typical value is tested when the scanner rotating frequency is 10Hz. With the same rotating speed, the PWM duty cycle of every RILIDAR A2 may vary slightly. If a precise rotating speed is required, users can perform a closed-loop control.

If the host system only need to control the start and stop of the motor, please use the direct current signal in high level and low level to drive MOTOCTL. Under this condition, when the MOTOCTL is the low level signal, the RPLIDAR A2 will stop rotating and scanning; when the MOTOCTL is the high level signal, the RPLIDAR A2 will rotated at the highest speed.

MISC

- For Model A2M5/A2M6 Only

Item	Unit	Min	Typical	Max	Comments
Weight	Gram (g)	TBD	190	TBD	
Temperature range	Degree Celsius (°C)	0	20	45	

Figure 2-10 RPLIDAR MISC Specification

To ensure the laser of RPLIDAR always working in the safety range ($<3\text{mW}$) and avoid any other damage caused by device, the RPLIDAR comes with laser power detection and sensor healthy check feature. It will shut down the laser and stop working automatically when any of the following errors has been detected.

- Laser transmit power exceeds limited value
- Laser cannot power on normally
- Scan speed of Laser scanner system is unstable
- Scan speed of Laser scanner system is too slow
- Laser signal sensor works abnormally

The host systems can check the status of the RPLIDAR via the communication interface and restart the RPLIDAR to try to recover work from error.

SLAMTEC provides debug GUI tool and SDK (available for Windows, x86 Linux and Arm Linux) to speed up the product development for users. Please contact SLAMTEC for detail information.

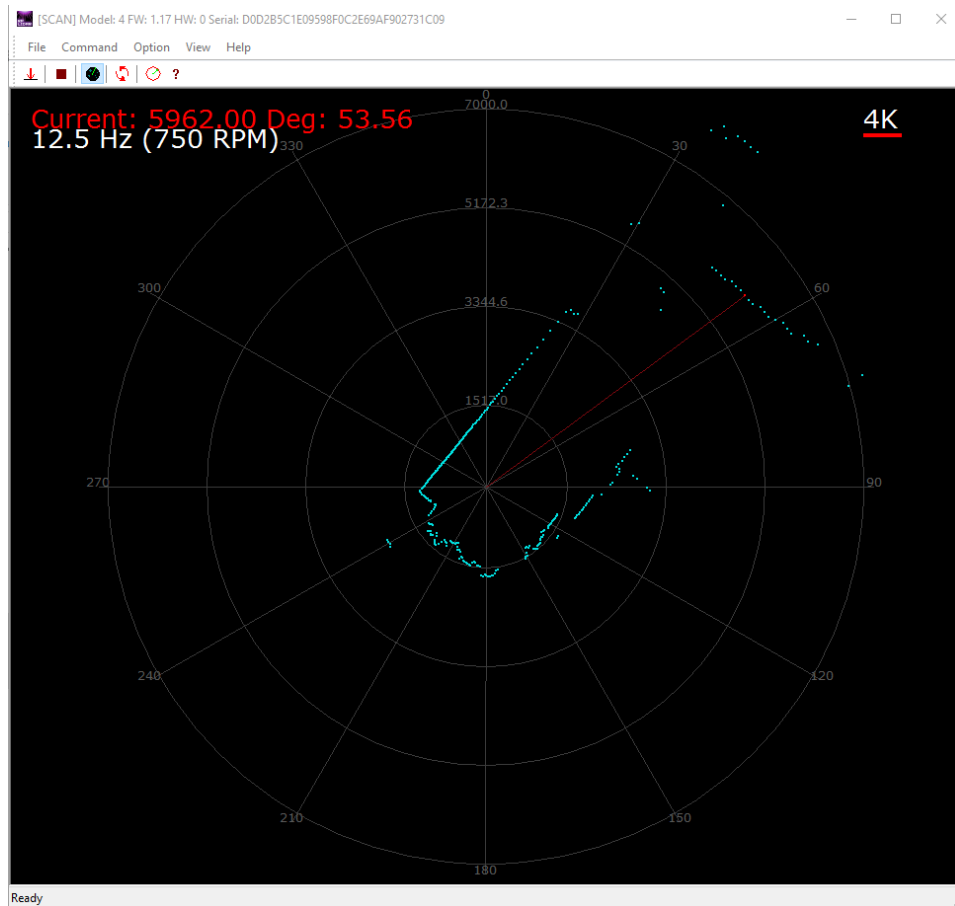

Figure 4-1 The Debugging GUI of RPLIDAR

The mechanical dimensions of the RPLIDAR A2 are shown as below:

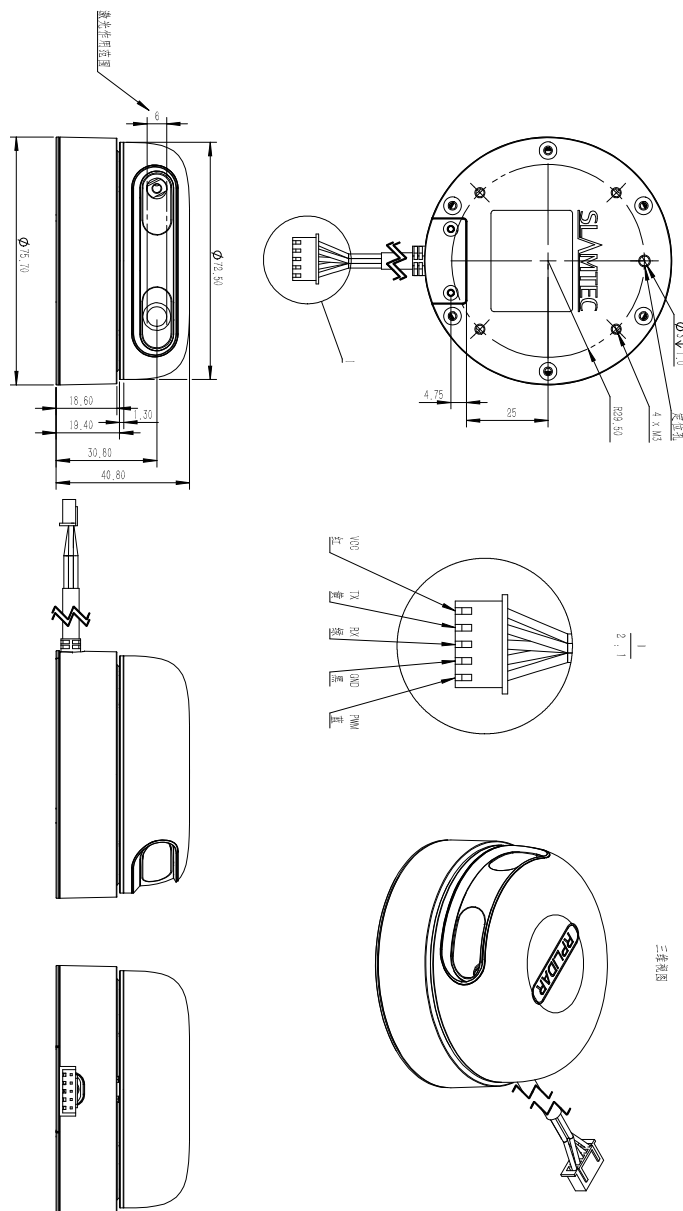

Figure 5-1 RPLIDAR Mechanical Dimensions

Note: the 4 * M3 screws in the bottom should be no longer than 4mm, or the internal module would be damaged.

Date	Version	Description
2016-08-12	0.1	Initial Version A2M5/A2M6

Image and Table Index

FIGURE 1-1 RPLIDAR SYSTEM COMPOSITION	4
FIGURE 1-2 THE RPLIDAR WORKING SCHEMATIC.....	5
FIGURE 1-3 THE OBTAINED ENVIRONMENT MAP FROM RPLIDAR SCANNING.....	6
FIGURE 1-4 THE RPLIDAR SAMPLE POINT DATA INFORMATION	7
FIGURE 1-5 THE RPLIDAR SAMPLE POINT DATA FRAMES.....	7
FIGURE 2-1 RPLIDAR PERFORMANCE	9
FIGURE 2-2 RPLIDAR OPTICAL SPECIFICATION.....	9
FIGURE 2-3 RPLIDAR OPTICAL WINDOW.....	10
FIGURE 2-4 RPLIDAR SCANNING DATA COORDINATE SYSTEM DEFINITION.....	11
FIGURE 2-5 RPLIDAR POWER INTERFACE DEFINITION.....	11
FIGURE 2-6 RPLIDAR EXTERNAL INTERFACE SIGNAL DEFINITION	12
FIGURE 2-7 RPLIDAR POWER SUPPLY SPECIFICATION.....	12
FIGURE 2-8 RPLIDAR SERIAL PORT INTERFACE SPECIFICATIONS	13
FIGURE 2-9 RPLIDA SPECIFICATION FOR PWM SIGNAL OF MOTOCTL.....	13
FIGURE 2-10 RPLIDAR MISC SPECIFICATION	14
FIGURE 4-1 THE DEBUGGING GUI OF RPLIDAR	16
FIGURE 5-1 RPLIDAR MECHANICAL DIMENSIONS.....	17