



Chipsmall Limited consists of a professional team with an average of over 10 year of expertise in the distribution of electronic components. Based in Hongkong, we have already established firm and mutual-benefit business relationships with customers from,Europe,America and south Asia,supplying obsolete and hard-to-find components to meet their specific needs.

With the principle of “Quality Parts,Customers Priority,Honest Operation,and Considerate Service”,our business mainly focus on the distribution of electronic components. Line cards we deal with include Microchip,ALPS,ROHM,Xilinx,Pulse,ON,Everlight and Freescale. Main products comprise IC,Modules,Potentiometer,IC Socket,Relay,Connector.Our parts cover such applications as commercial,industrial, and automotives areas.

We are looking forward to setting up business relationship with you and hope to provide you with the best service and solution. Let us make a better world for our industry!



Contact us

Tel: +86-755-8981 8866 Fax: +86-755-8427 6832

Email & Skype: info@chipsmall.com Web: www.chipsmall.com

Address: A1208, Overseas Decoration Building, #122 Zhenhua RD., Futian, Shenzhen, China





68-Pin PLCC-to-DIP 64-Pin Motorola MC68HC000 Adapter

FEATURES

- Allows easy replacement of a difficult-to-find part.

GENERAL SPECIFICATIONS

- PCB: FR-4, 0.062 [1.56] or 0.094 [2.39] thick
- MALE PINS: Brass 360 1/2-hard per UNS C36000, ASTM B16/B16M
- MALE PIN PLATING: 200 μ [5.08 μ] Sn/Pb 93/7 per ASTM B579-73 over 100 μ [2.54 μ] Ni per SAE AMS-QQ-N-290
- OPERATING TEMPERATURE: 221°F [105°C]

MOUNTING CONSIDERATIONS

- Standard thru-hole

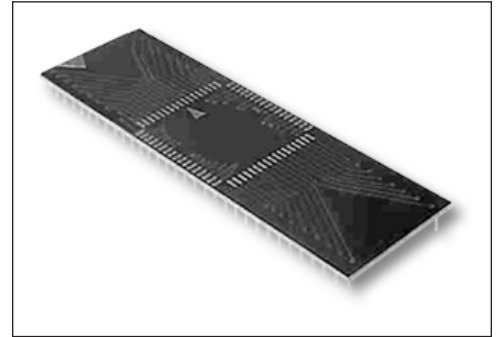

CUSTOMIZATION: In addition to the standard products shown on this page, Aries specializes in custom design and production. Special materials, platings, sizes, and configurations can be furnished, depending on the quantity. **NOTE:** Aries reserves the right to change product general specifications without notice.

PCB	IC	PCB	IC
1	1	33	36
2	2	34	37
3	3	35	38
4	4	36	39
5	5	37	40
6	6	38	41
7	7	39	42
8	8	40	43
9	9	41	44
10	10	42	45
11	11	43	46
12	12	44	47
13	13	45	48
14	14	46	49
15	15	47	50
16	16&17	48	51
17	19	49	52
18	20	50	52
19	21	51	54
20	22	52	55
21	23	53	56&57
22	24	54	58
23	25	55	59
24	26	56	60
25	27	57	61
26	28	58	62
27	29	59	63
28	30	60	64
29	32	61	65
30	33	62	66
31	34	63	67
32	35	64	68

ORDERING INFORMATION

1110267-N-P

Optional Panalized Form

ALL DIMENSIONS: INCHES [MILLIMETERS]
 ALL TOLERANCES: ± 0.005 [0.13] UNLESS OTHERWISE SPECIFIED
 CONSULT FACTORY FOR OTHER SIZES AND CONFIGURATIONS

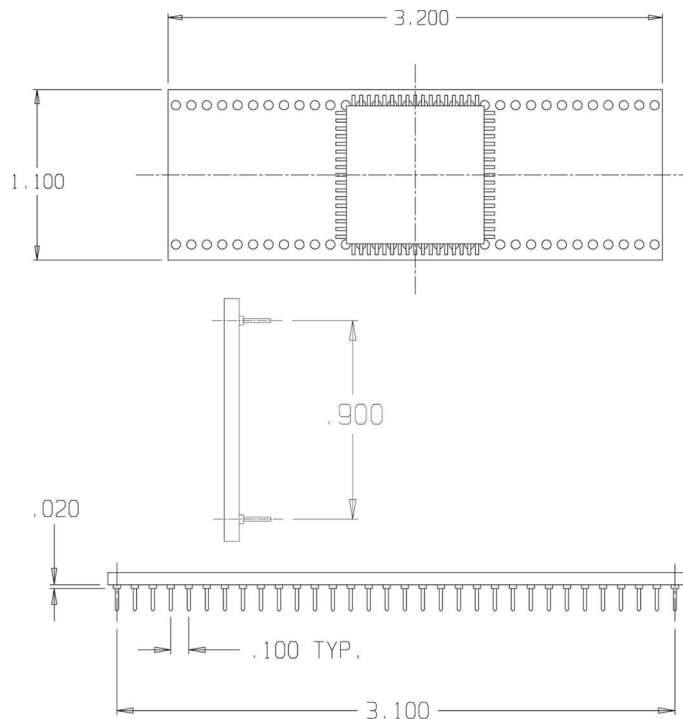

Bristol, PA 19007-6810 USA
 TEL (215) 781-9956 • FAX (215) 781-9845
 WWW.ARIESELEC.COM • INFO@ARIESELEC.COM