



Chipsmall Limited consists of a professional team with an average of over 10 year of expertise in the distribution of electronic components. Based in Hongkong, we have already established firm and mutual-benefit business relationships with customers from,Europe,America and south Asia,supplying obsolete and hard-to-find components to meet their specific needs.

With the principle of “Quality Parts,Customers Priority,Honest Operation,and Considerate Service”,our business mainly focus on the distribution of electronic components. Line cards we deal with include Microchip,ALPS,ROHM,Xilinx,Pulse,ON,Everlight and Freescale. Main products comprise IC,Modules,Potentiometer,IC Socket,Relay,Connector.Our parts cover such applications as commercial,industrial, and automotives areas.

We are looking forward to setting up business relationship with you and hope to provide you with the best service and solution. Let us make a better world for our industry!



Contact us

Tel: +86-755-8981 8866 Fax: +86-755-8427 6832

Email & Skype: info@chipsmall.com Web: www.chipsmall.com

Address: A1208, Overseas Decoration Building, #122 Zhenhua RD., Futian, Shenzhen, China



THREE PHASE CONTROLLED BRIDGE

Power Modules

Features

- Package fully compatible with the industry standard INT-A-pak power modules series
- High thermal conductivity package, electrically insulated case
- Outstanding number of power encapsulated components
- Excellent power volume ratio
- 4000 V_{RMS} isolating voltage
- UL E78996 approved 

55 A
90 A
110 A

Description

A range of extremely compact, encapsulated three phase controlled bridge rectifiers offering efficient and reliable operation. They are intended for use in general purpose and heavy duty applications.

Major Ratings and Characteristics

Parameters	53MT.KB 52MT.KB 51MT.KB	93MT.KB 92MT.KB 91MT.KB	113MT.KB 112MT.KB 111MT.KB	Units
I_o	55	90	110	A
@ T_c	85	85	85	°C
I_{FSM} @ 50Hz	390	950	1130	A
@ 60Hz	410	1000	1180	A
I^2t @ 50Hz	770	4525	6380	A ² s
@ 60Hz	700	4130	5830	A ² s
$I^2\sqrt{t}$	7700	45250	63800	A ² √s
V_{RRM} range	800 to 1600			V
T_{STG} range	-40 to 125			°C
T_J range	-40 to 125			°C

53-93-113MT..KB Series

Bulletin I27503 08/97

International
 Rectifier

ELECTRICAL SPECIFICATIONS

Voltage Ratings

Type number	Voltage Code	V_{RRM} , maximum repetitive peak reverse voltage V	V_{RSM} , maximum non-repetitive peak reverse voltage V	V_{DRM} , max. repetitive peak off-state voltage gate open circuit V	I_{RRM}/I_{DRM} max. @ $T_J = 125^\circ\text{C}$ mA
53/52/51MT..KB	80	800	900	800	10
	100	1000	1100	1000	
	120	1200	1300	1200	
	140	1400	1500	1400	
	160	1600	1700	1600	
93/92/91MT..KB 113/112/111MT..KB	80	800	900	800	20
	100	1000	1100	1000	
	120	1200	1300	1200	
	140	1400	1500	1400	
	160	1600	1700	1600	

Forward Conduction

Parameter	53MT.KB 52MT.KB 51MT.KB	93MT.KB 92MT.KB 91MT.KB	113MT.KB 112MT.KB 111MT.KB	Units	Conditions
I_O Maximum DC output current @ Case temperature	55	90	110	A	120° Rect conduction angle
	85	85	85	°C	
I_{TSM} Maximum peak, one-cycle forward, non-repetitive on state surge current	390	950	1130	A	t = 10ms No voltage reappplied
	410	1000	1180		t = 8.3ms
	330	800	950		t = 10ms 100% V_{RRM} reappplied
	345	840	1000		t = 8.3ms
I^2t Maximum I^2t for fusing	770	4525	6380	A ² s	t = 10ms No voltage reappplied
	700	4130	5830		t = 8.3ms
	540	3200	4510		t = 10ms 100% V_{RRM} reappplied
	500	2920	4120		t = 8.3ms
$I^2\sqrt{t}$ Maximum $I^2\sqrt{t}$ for fusing	7700	45250	63800	A ² √s	t = 0.1 to 10ms, no voltage reappplied
$V_{T(TO)1}$ Low level value of threshold voltage	1.17	1.09	1.04	V	(16.7% x π x $I_{T(AV)} < I < \pi$ x $I_{T(AV)}$), @ T_J max.
$V_{T(TO)2}$ High level value of threshold voltage	1.45	1.27	1.27		($I > \pi$ x $I_{T(AV)}$), @ T_J max.
$r_{\theta 1}$ Low level value on-state slope resistance	12.40	4.10	3.93	mΩ	(16.7% x π x $I_{T(AV)} < I < \pi$ x $I_{T(AV)}$), @ T_J max.
$r_{\theta 2}$ High level value on-state slope resistance	11.04	3.59	3.37		($I > \pi$ x $I_{T(AV)}$), @ T_J max.
V_{TM} Maximum on-state voltage drop	2.68	1.65	1.57	V	$I_{pk} = 150\text{A}$, $T_J = 25^\circ\text{C}$ $t_p = 400\mu\text{s}$ single junction
di/dt Max. non-repetitive rate of rise of turned on current	150			A/μs	$T_J = 25^\circ\text{C}$, from 0.67 V_{DRM} , $I_{TM} = \pi$ x $I_{T(AV)}$, $I_g = 500\text{mA}$, $t_r < 0.5\mu\text{s}$, $t_p > 6\mu\text{s}$
I_H Max. holding current	200			mA	$T_J = 25^\circ\text{C}$, anode supply = 6V, resistive load, gate open circuit
I_L Max. latching current	400				$T_J = 25^\circ\text{C}$, anode supply = 6V, resistive load

Blocking

Parameter	53MT.KB 52MT.KB 51MT.KB	93MT.KB 92MT.KB 91MT.KB	113MT.KB 112MT.KB 111MT.KB	Units	Conditions
V _{INS} RMS isolation voltage	4000			V	T _J = 25°C all terminal shorted f = 50Hz, t = 1s
dv/dt Max. critical rate of rise of off-state voltage (*)	500			V/μs	T _J = T _J max., linear to 0.67 V _{DRM} , gate open circuit

(*) Available with dv/dt = 1000V/ms, to complete code add S90 i.e. 113MT160KBS90.

Triggering

Parameter	53MT.KB 52MT.KB 51MT.KB	93MT.KB 92MT.KB 91MT.KB	113MT.KB 112MT.KB 111MT.KB	Units	Conditions	
P _{GM} Max. peak gate power	10			W	T _J = T _J max.	
P _{G(AV)} Max. average gate power	2.5					
I _{GM} Max. peak gate current	2.5			A		
-V _{GT} Max. peak negative gate voltage	10			V		
V _{GT} Max. required DC gate voltage to trigger	4.0			V	T _J = -40°C	
	2.5				T _J = 25°C	Anode supply = 6V, resistive load
	1.7				T _J = 125°C	
I _{GT} Max. required DC gate current to trigger	270			mA	T _J = -40°C	
	150				T _J = 25°C	Anode supply = 6V, resistive load
	80				T _J = 125°C	
V _{GD} Max. gate voltage that will not trigger	0.25			V	@ T _J = T _J max., rated V _{DRM} applied	
I _{GD} Max. gate current that will not trigger	6			mA		

Thermal and Mechanical Specifications

Parameter	53MT.KB 52MT.KB 51MT.KB	93MT.KB 92MT.KB 91MT.KB	113MT.KB 112MT.KB 111MT.KB	Units	Conditions
T _J Max. junction operating temperature range	-40 to 125			°C	
T _{slg} Max. storage temperature range	-40 to 125			°C	
R _{thJC} Max. thermal resistance, junction to case	0.18	0.14	0.12	K/W	DC operation per module
	1.07	0.86	0.70		DC operation per junction
	0.19	0.15	0.12		120° Rect conduction angle per module
	1.17	0.91	0.74		120° Rect conduction angle per junction
R _{thCS} Max. thermal resistance, case to heatsink	0.03			K/W	Per module Mounting surface smooth, flat and greased
T Mounting torque ± 10%	to heatsink	4 to 6		Nm	A mounting compound is recommended and the torque should be rechecked after a period of 3 hours to allow for the spread of the compound. Lubricated threads.
	to terminal	3 to 4			
wt Approximate weight	225			g	

53-93-113MT.KB Series

Bulletin I27503 08/97

International
IR Rectifier

ΔR Conduction (per Junction)

(The following table shows the increment of thermal resistance R_{thJC} when devices operate at different conduction angles than DC)

Devices	Sinusoidal conduction @ T_J max.					Rectangular conduction @ T_J max.					Units
	180°	120°	90°	60°	30°	180°	120°	90°	60°	30°	
53/52/51MT.KB	0.072	0.085	0.108	0.152	0.233	0.055	0.091	0.117	0.157	0.236	K/W
93/92/91MT.KB	0.033	0.039	0.051	0.069	0.099	0.027	0.044	0.055	0.071	0.100	
113/112/111MT.KB	0.027	0.033	0.042	0.057	0.081	0.023	0.037	0.046	0.059	0.082	

Ordering Information Table

Device Code

11	3	MT	160	K	B	S90
①	②	③	④	⑤	⑥	

- 1** - Current rating code: 5 = 55 A (Avg)
9 = 90 A (Avg)
11 = 110 A (Avg)
- 2** - Circuit configuration code: 3 = Full-controlled bridge
2 = Positive half-controlled bridge
1 = Negative half-controlled bridge
- 3** - Essential part number
- 4** - Voltage code: Code x 10 = V_{RRM} (See Voltage Ratings Table)
- 5** - Generation II
- 6** - Critical dv/dt: None = 500V/μs (Standard value)
S90 = 1000V/μs (Special selection)

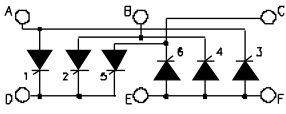

full-controlled bridge
(53, 93, 113MT..KB)

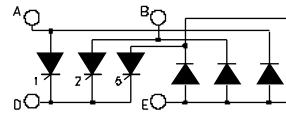

positive half-controlled bridge
(52, 92, 112MT..KB)

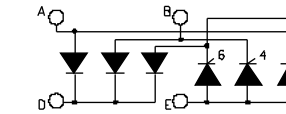

negative half-controlled bridge
(51, 91, 111MT..KB)

NOTE: To order the Optional Hardware see Bulletin I27900

Document Number: 93557

www.vishay.com

Outline Table (with optional barriers)

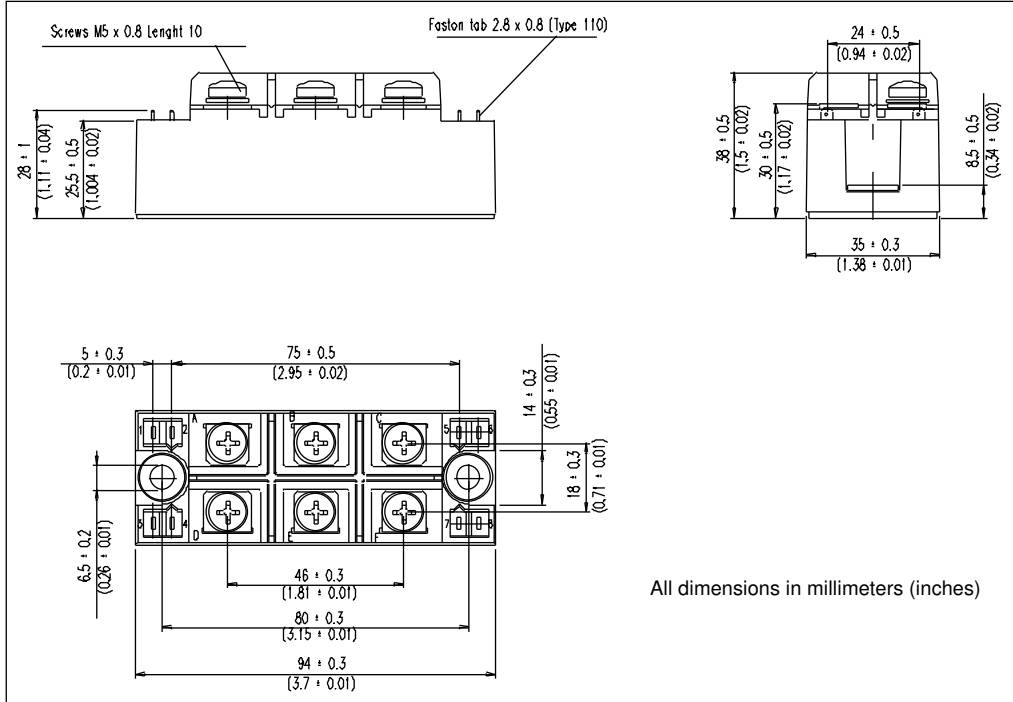

Outline Table (without optional barriers)

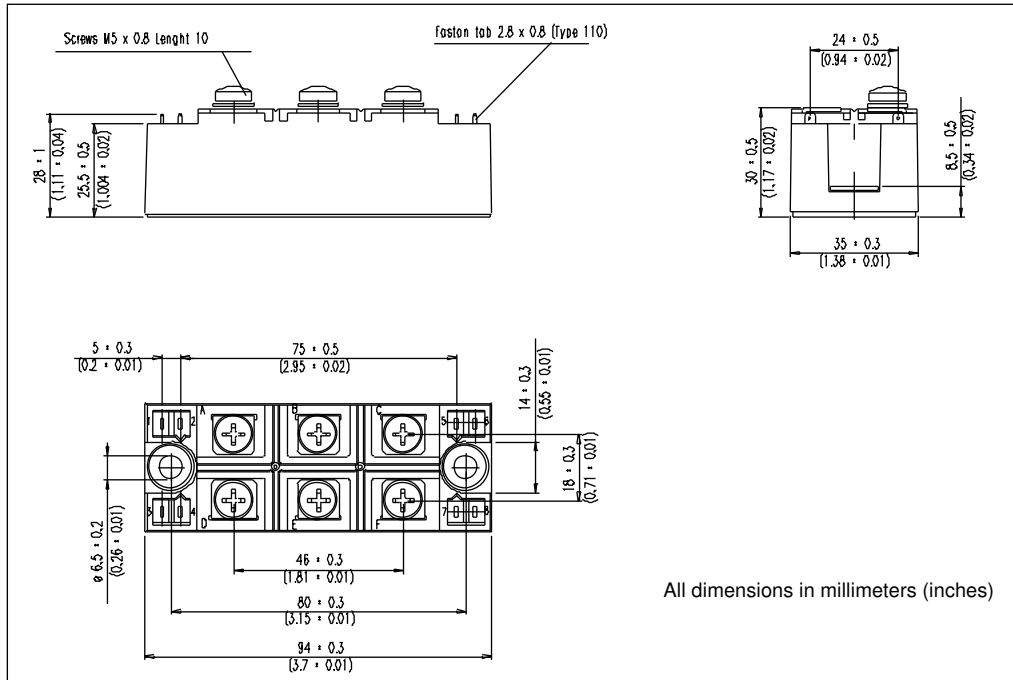

53-93-113MT..KB Series

Bulletin I27503 08/97

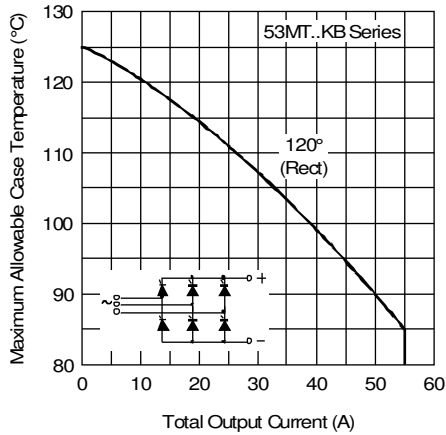

Fig. 1 - Current Ratings Characteristic

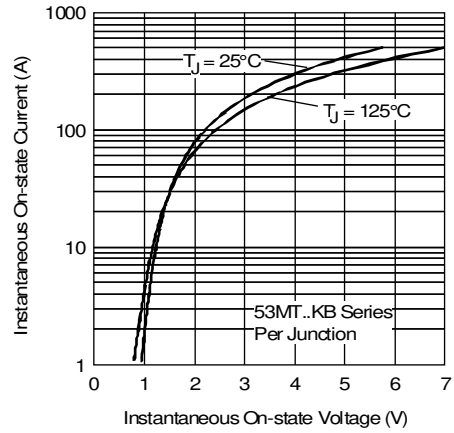

Fig. 2 - Forward Voltage Drop Characteristics

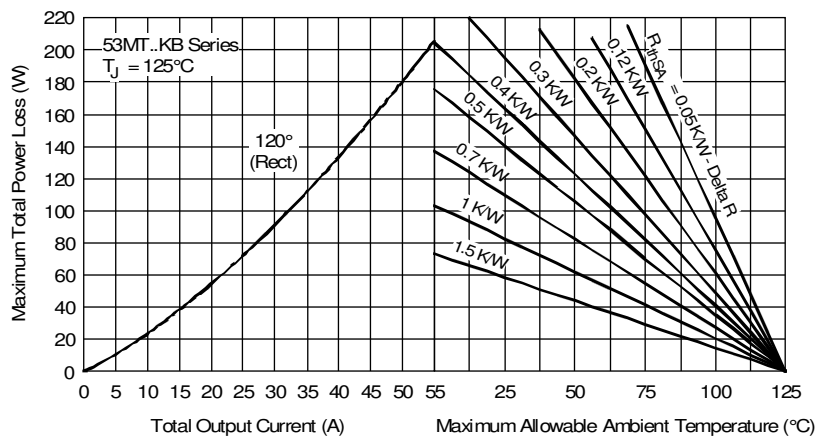

Fig. 3 - Total Power Loss Characteristics

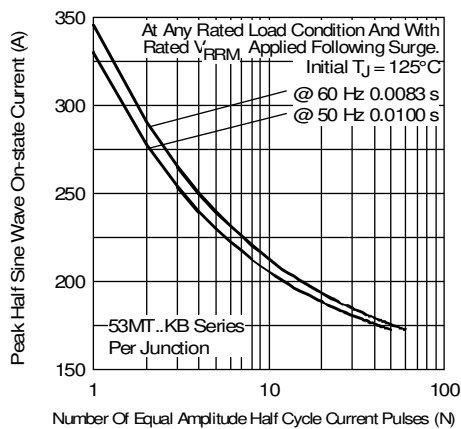

Fig. 4 - Maximum Non-Repetitive Surge Current

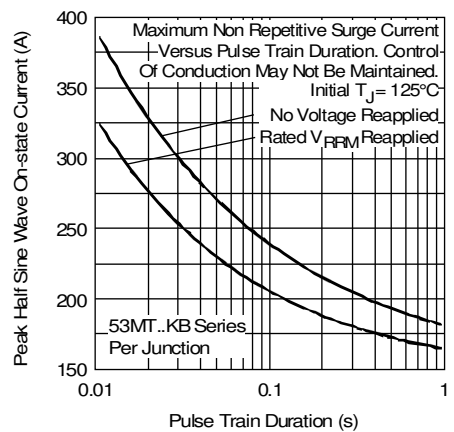

Fig. 5 - Maximum Non-Repetitive Surge Current

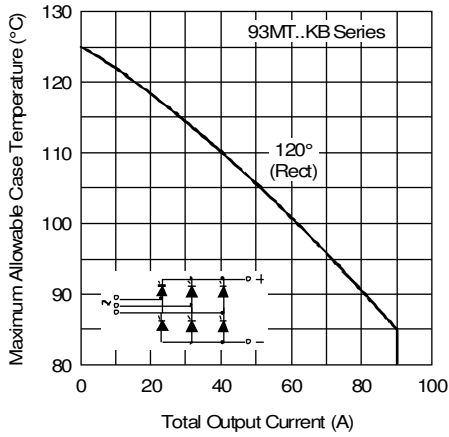

Fig. 6 - Current Ratings Characteristic

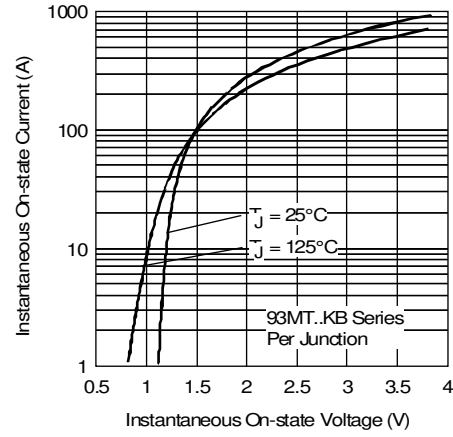

Fig. 7 - Forward Voltage Drop Characteristics

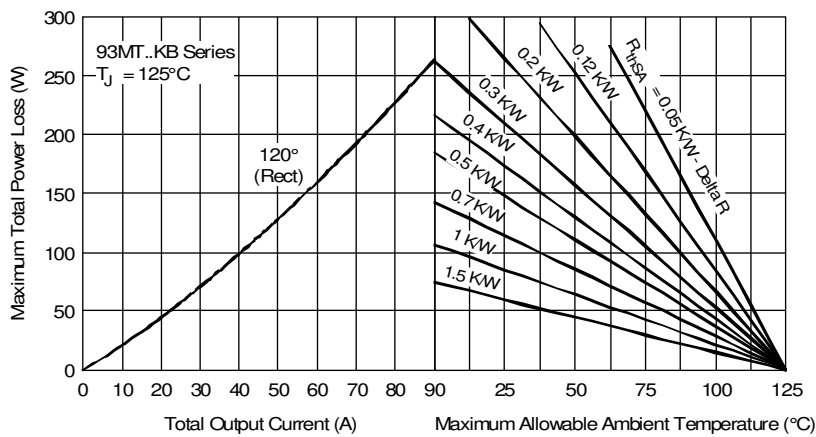

Fig. 8 - Total Power Loss Characteristics

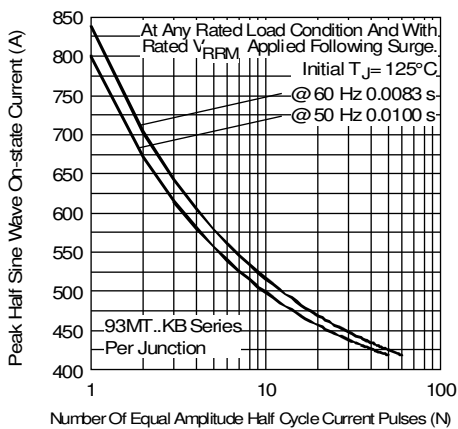

Fig. 9 - Maximum Non-Repetitive Surge Current

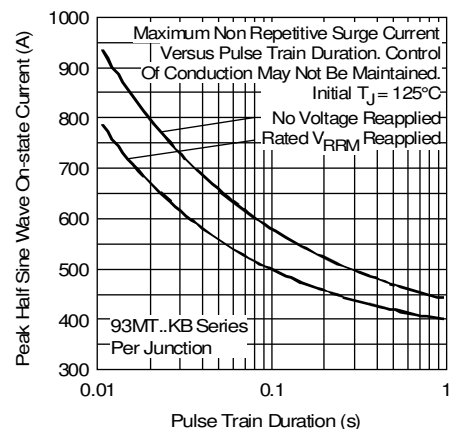

Fig. 10 - Maximum Non-Repetitive Surge Current

53-93-113MT..KB Series

Bulletin I27503 08/97

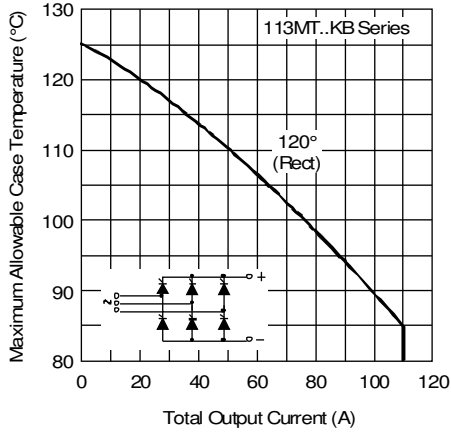

Fig. 11 - Current Ratings Characteristic

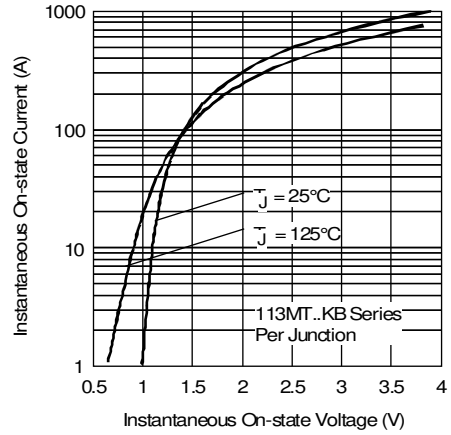

Fig. 12 - Forward Voltage Drop Characteristics

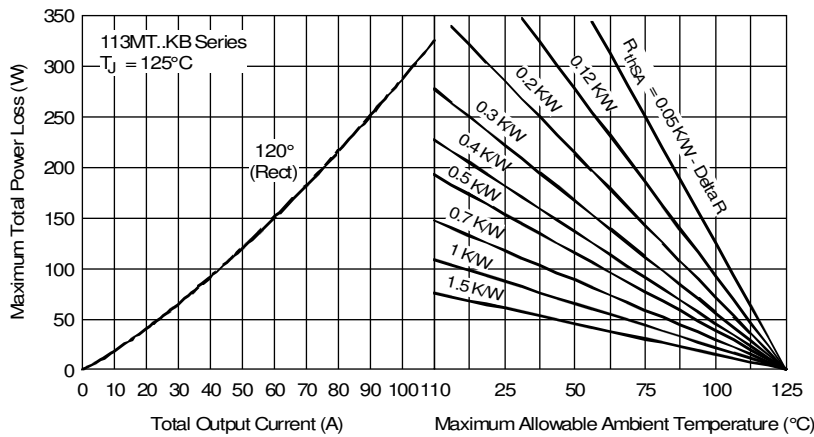

Fig. 13 - Total Power Loss Characteristics

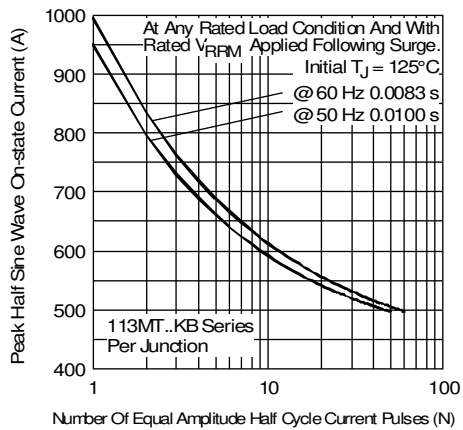

Fig. 14 - Maximum Non-Repetitive Surge Current

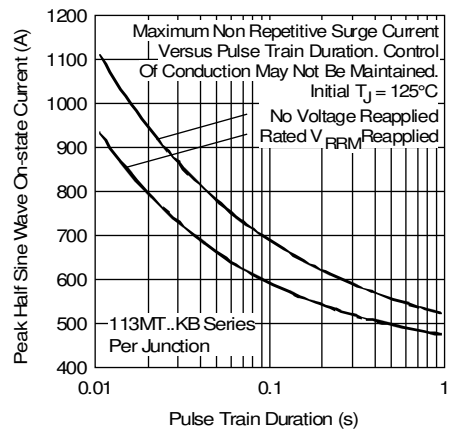

Fig. 15 - Maximum Non-Repetitive Surge Current

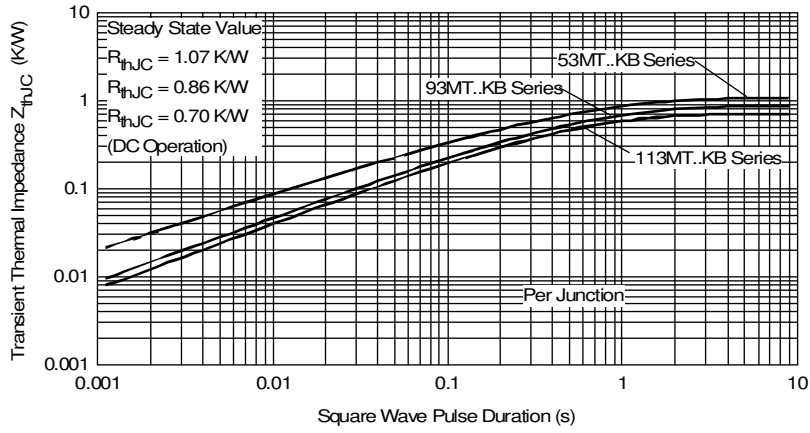

Fig. 16 - Thermal Impedance Z_{thJC} Characteristics

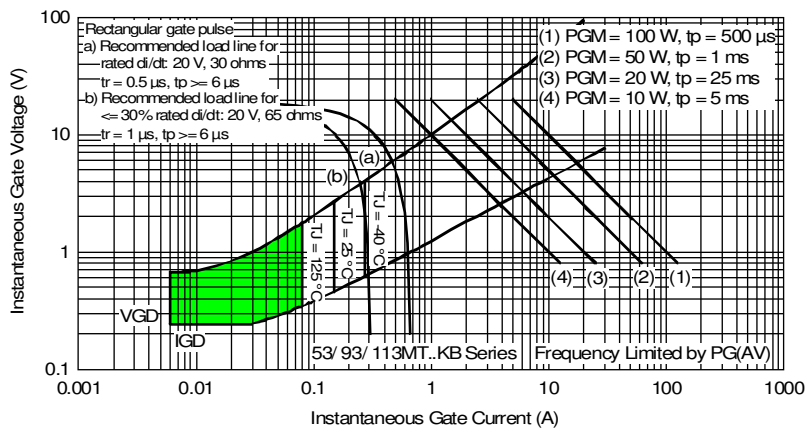

Fig. 17 - Gate Characteristics



Notice

The products described herein were acquired by Vishay Intertechnology, Inc., as part of its acquisition of International Rectifier's Power Control Systems (PCS) business, which closed in April 2007. Specifications of the products displayed herein are pending review by Vishay and are subject to the terms and conditions shown below.

Specifications of the products displayed herein are subject to change without notice. Vishay Intertechnology, Inc., or anyone on its behalf, assumes no responsibility or liability for any errors or inaccuracies.

Information contained herein is intended to provide a product description only. No license, express or implied, by estoppel or otherwise, to any intellectual property rights is granted by this document. Except as provided in Vishay's terms and conditions of sale for such products, Vishay assumes no liability whatsoever, and disclaims any express or implied warranty, relating to sale and/or use of Vishay products including liability or warranties relating to fitness for a particular purpose, merchantability, or infringement of any patent, copyright, or other intellectual property right.

The products shown herein are not designed for use in medical, life-saving, or life-sustaining applications. Customers using or selling these products for use in such applications do so at their own risk and agree to fully indemnify Vishay for any damages resulting from such improper use or sale.

International Rectifier®, IR®, the IR logo, HEXFET®, HEXSense®, HEXDIP®, DOL®, INTERO®, and POWIRTRAIN® are registered trademarks of International Rectifier Corporation in the U.S. and other countries. All other product names noted herein may be trademarks of their respective owners.