



Chipsmall Limited consists of a professional team with an average of over 10 year of expertise in the distribution of electronic components. Based in Hongkong, we have already established firm and mutual-benefit business relationships with customers from,Europe,America and south Asia,supplying obsolete and hard-to-find components to meet their specific needs.

With the principle of “Quality Parts,Customers Priority,Honest Operation,and Considerate Service”,our business mainly focus on the distribution of electronic components. Line cards we deal with include Microchip,ALPS,ROHM,Xilinx,Pulse,ON,Everlight and Freescale. Main products comprise IC,Modules,Potentiometer,IC Socket,Relay,Connector.Our parts cover such applications as commercial,industrial, and automotives areas.

We are looking forward to setting up business relationship with you and hope to provide you with the best service and solution. Let us make a better world for our industry!



Contact us

Tel: +86-755-8981 8866 Fax: +86-755-8427 6832

Email & Skype: info@chipsmall.com Web: www.chipsmall.com

Address: A1208, Overseas Decoration Building, #122 Zhenhua RD., Futian, Shenzhen, China



UG163: Si1133/Si1153 Optical Sensor Evaluation Board User's Guide

The optical sensor expansion board is designed to allow customers to evaluate the Si1133 UV/ALS sensor and other Si1153 sensors. A list of these sensors and their capabilities follows:

- **UV/ALS**—Si1133 sensor mounted with a demonstration light diffuser assembly.
- **Long Range Proximity**—Si1153-AA09 2X2 mm proximity sensing chip with an on-die 940 nm bandpass filter for sunlight immunity. The Board demonstrates the use of a 5 mm dia. lens and arrow-angle LED.
- **Sunlight Immune Proximity Module**—Si1153-AA09, 2.85 x 4.9 mm proximity sensing module with an on-die 940 nm bandpass filter for sunlight immunity and an integrated 940 nm LED.
- **Proximity/ALS**—Si1153-AA00, 2 x 2 mm light sensor chip. The Board uses a single 850 nm LED for demonstration purposes.
- **Gesture/ALS**—Si1153-AA00, 2 x 2 mm light sensor chip. The Board uses three 850 nm LEDs spaced roughly 50 mm apart for demonstration purposes.

The optical sensor expansion board is designed to allow customers to connect to the sensors using two methods:

- Silicon Labs EFM series of EVBs with an expansion ports. e.g. EFM32WG-STK3800 (Wonder Gecko) or EFM32ZG-STK3200 Zero Gecko Starter Kits
- USB connectivity via the Optical Sensors Programmers Toolkit

Note: Simplicity Studio sample code will be available in Q2 2016.

KEY FEATURES

- UV/ALS Sensor
- Long-Range Proximity Sensor
- Sunlight-Immune Proximity Module Sensor
- Gesture/ALS Sensor
- Compatible with Silicon Labs EFM EVBs and Optical Sensors Programmer Kit
- Simplicity Studio compatible

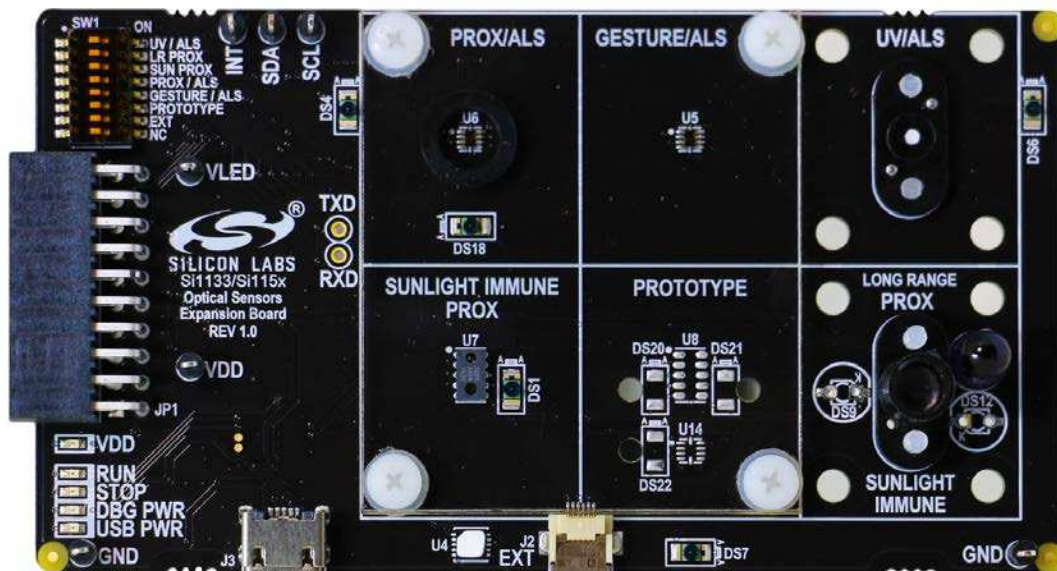

1. EVb Architecture

1.1 Board Block Diagram

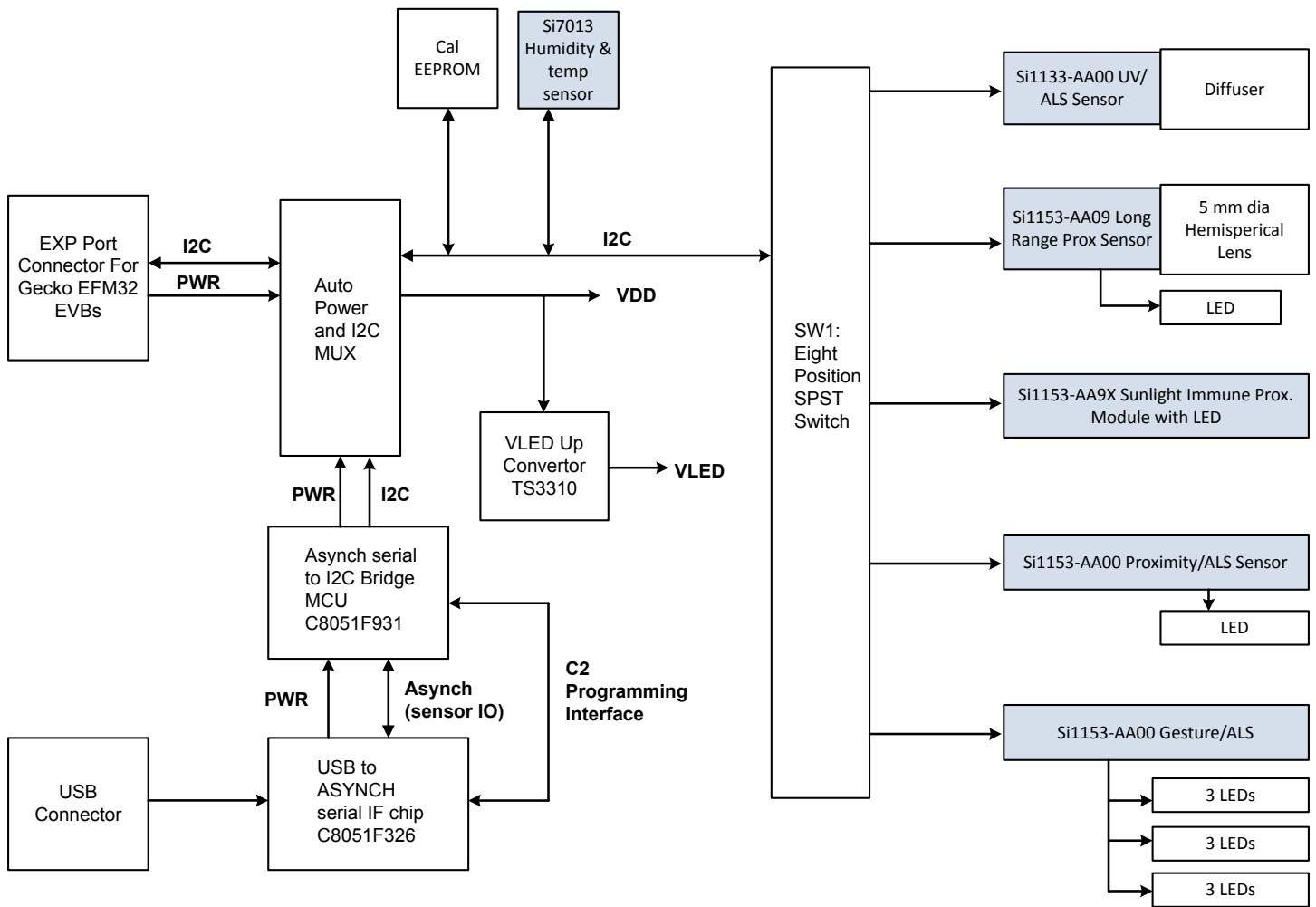

Figure 1.1. EVb Block Diagram (Silicon Labs Sensors Shown in Blue)

1.2 System Block Diagram with an EFM32 Host

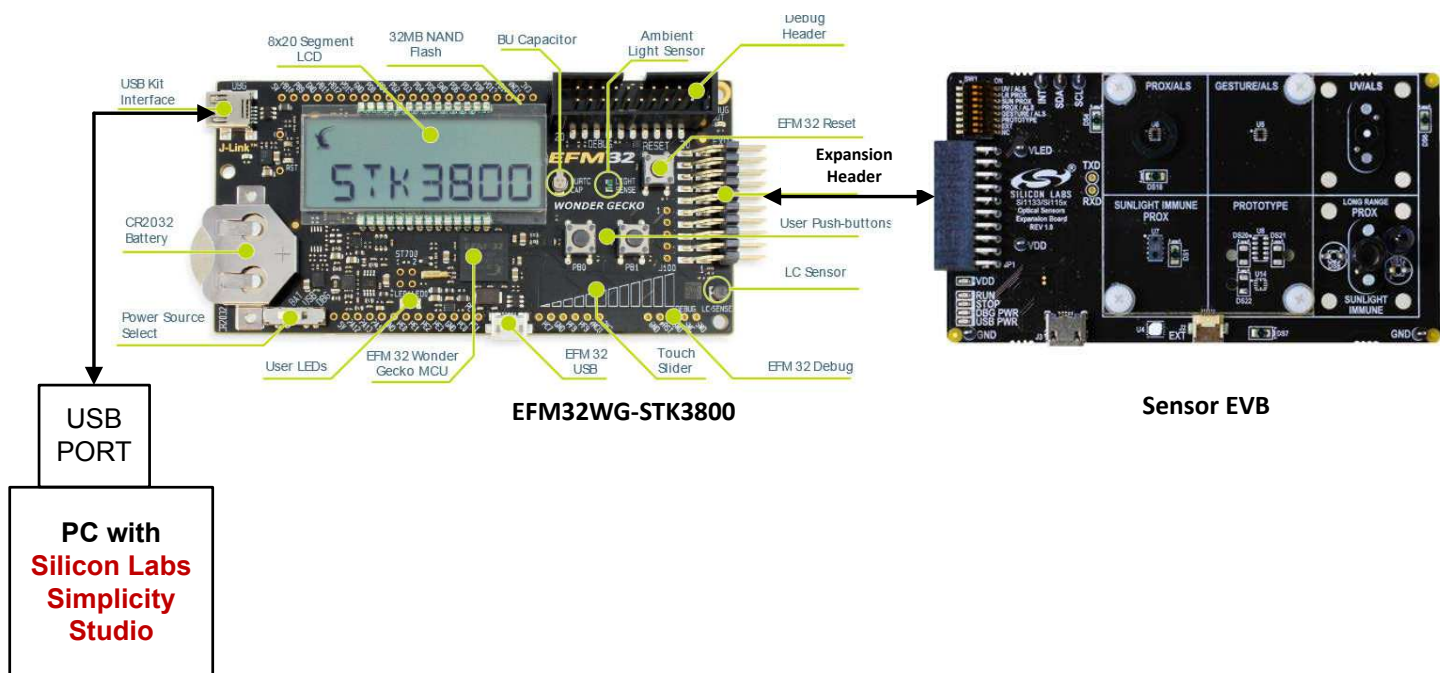

Figure 1.2. System Diagram with EFM Host

1.3 System Block Diagram with a PC Remote Host

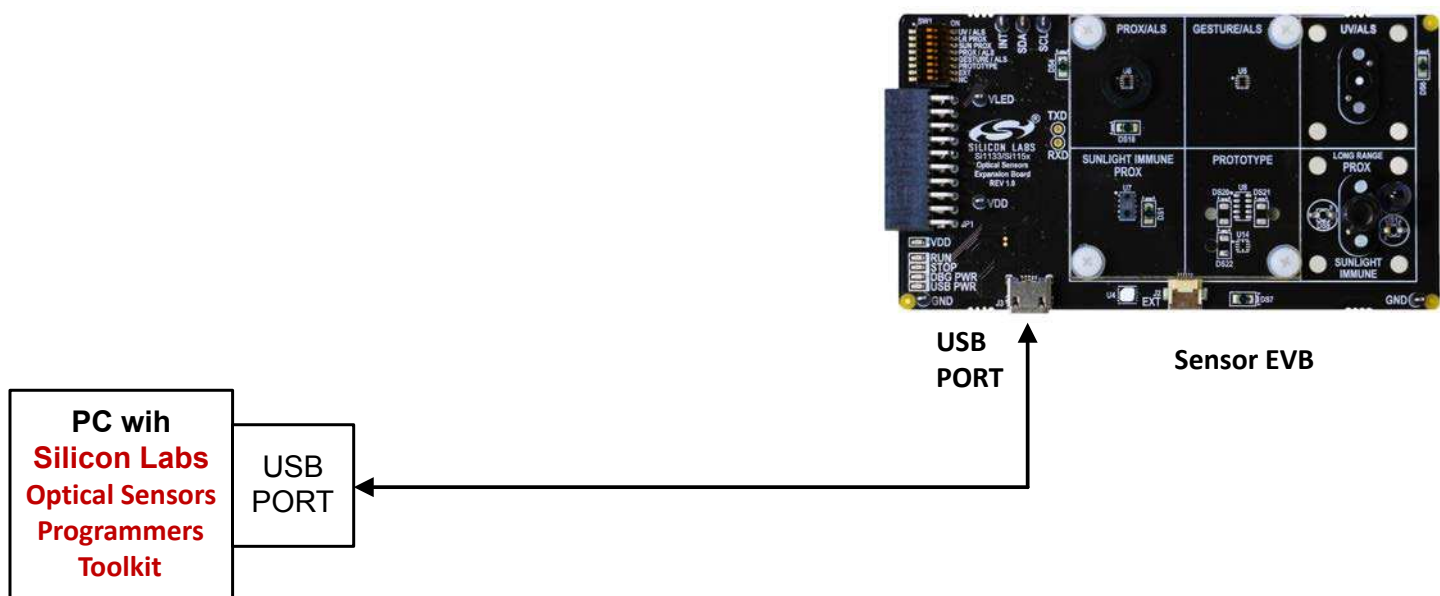

Figure 1.3. System Block Diagram with PC Remote Host

2. Board Setup and Use

2.1 SW1 Switch Configuration

It is important to note that only one of the sensors can be used at a time. That means only one of the 8 switches in SW1 should be moved to the left at a time. Each of the first 5 switches selects a different sensor on the board. The sixth position selects a prototype area, the seventh selects an external expansion connector compatible with the silicon labs postage stamp boards while the last is not used.

It is important to note that whenever the user wants to switch between sensors the board must be reset and the software started. This is because only the SDA SCL line is switched by SW1 and a sensor that has set up could be generating interrupts when you want to switch to another sensor.

2.2 Board Setup for UV/ALS and the Optical Programmer's Toolkit

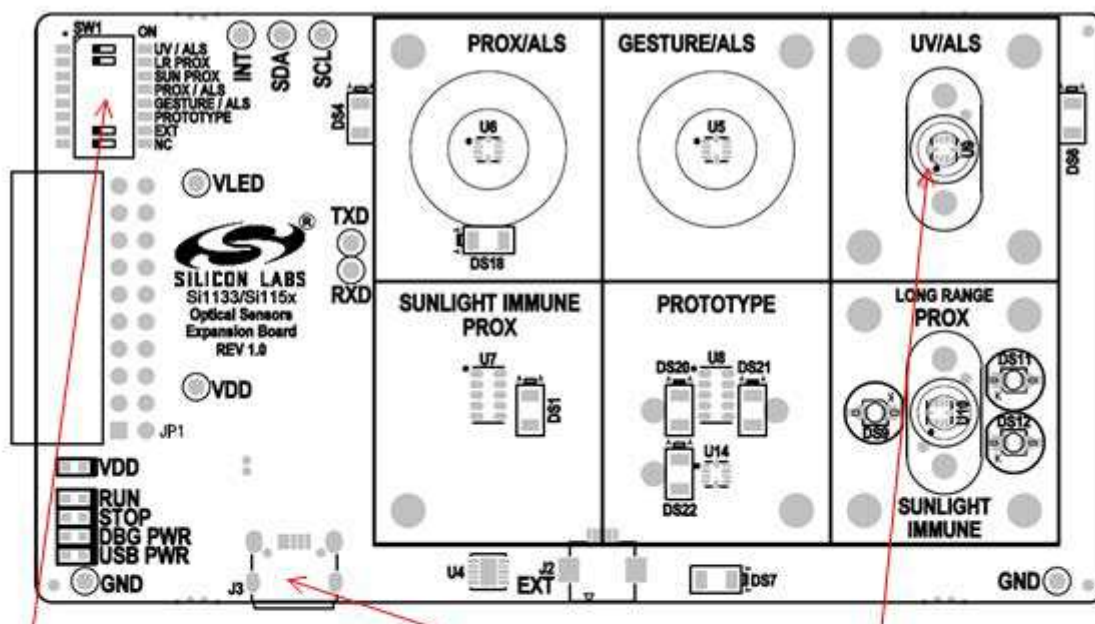

Make Sure only the desired sensor is selected before attaching USB cable

Connect to PC's USB Port with Supplied Cable

The UV sensor (Si1133) is under this diffuser assembly. The sensor is most accurate when used with such a small diffuser.

Figure 2.1. Board Setup for UV/ALS and Optical Programmer's Toolkit Using a USB Port

2.3 Installation and Basic Use of the Optical Programmer's Toolkit

1. Download and install Rev 3.2 or higher of the Silicon Labs Optical Programmers toolkit.
2. Once installed, launch the application using: Start >> All Programs >> Silicon Labs >> Si114x Optical Sensor >> Launcher
3. Select UV and ALS Demo, and then click on the UV_ALS_DEMO button, as shown in the figures below.

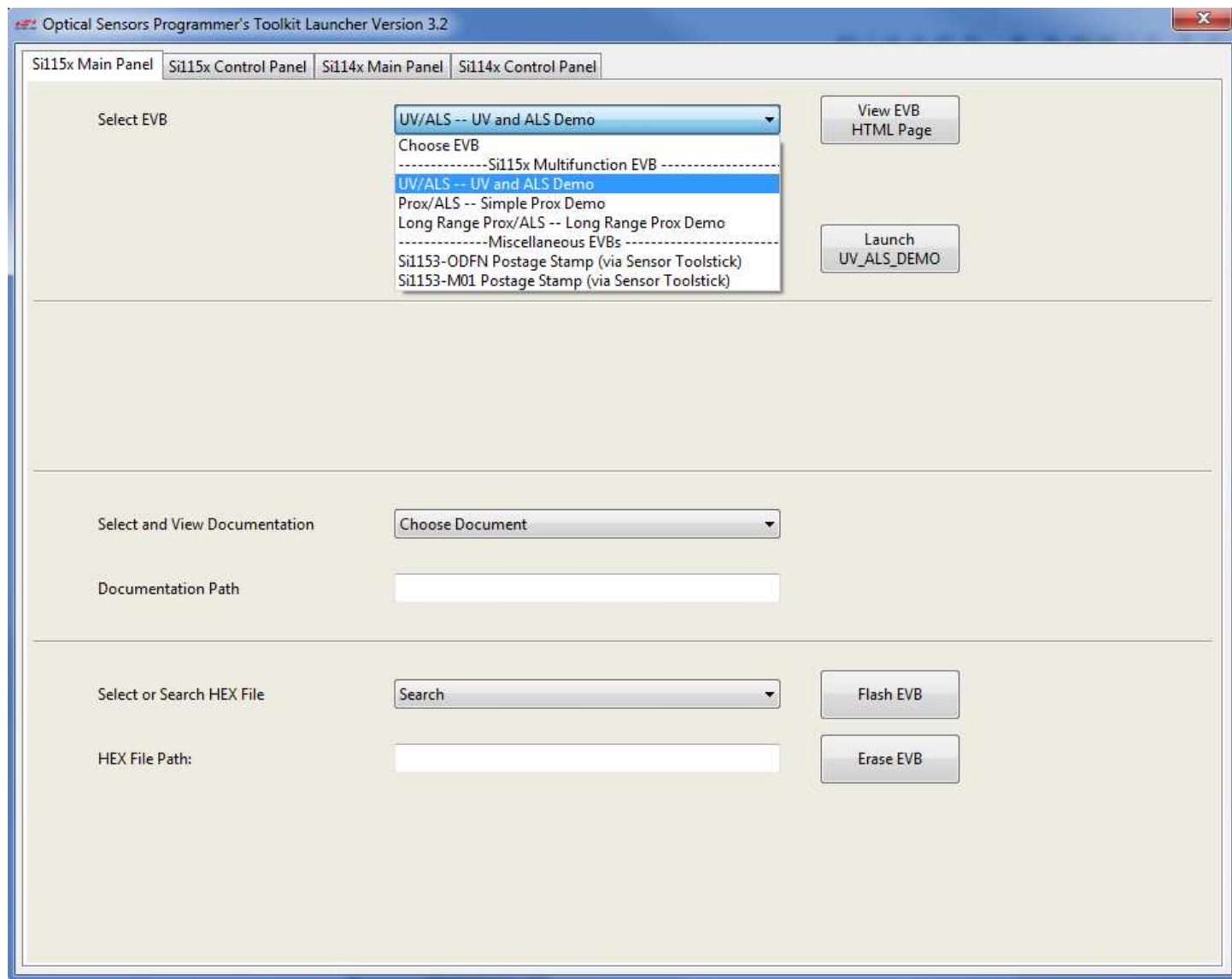

Figure 2.2. Starting the Programmer's Toolkit and UV/ALS Demo

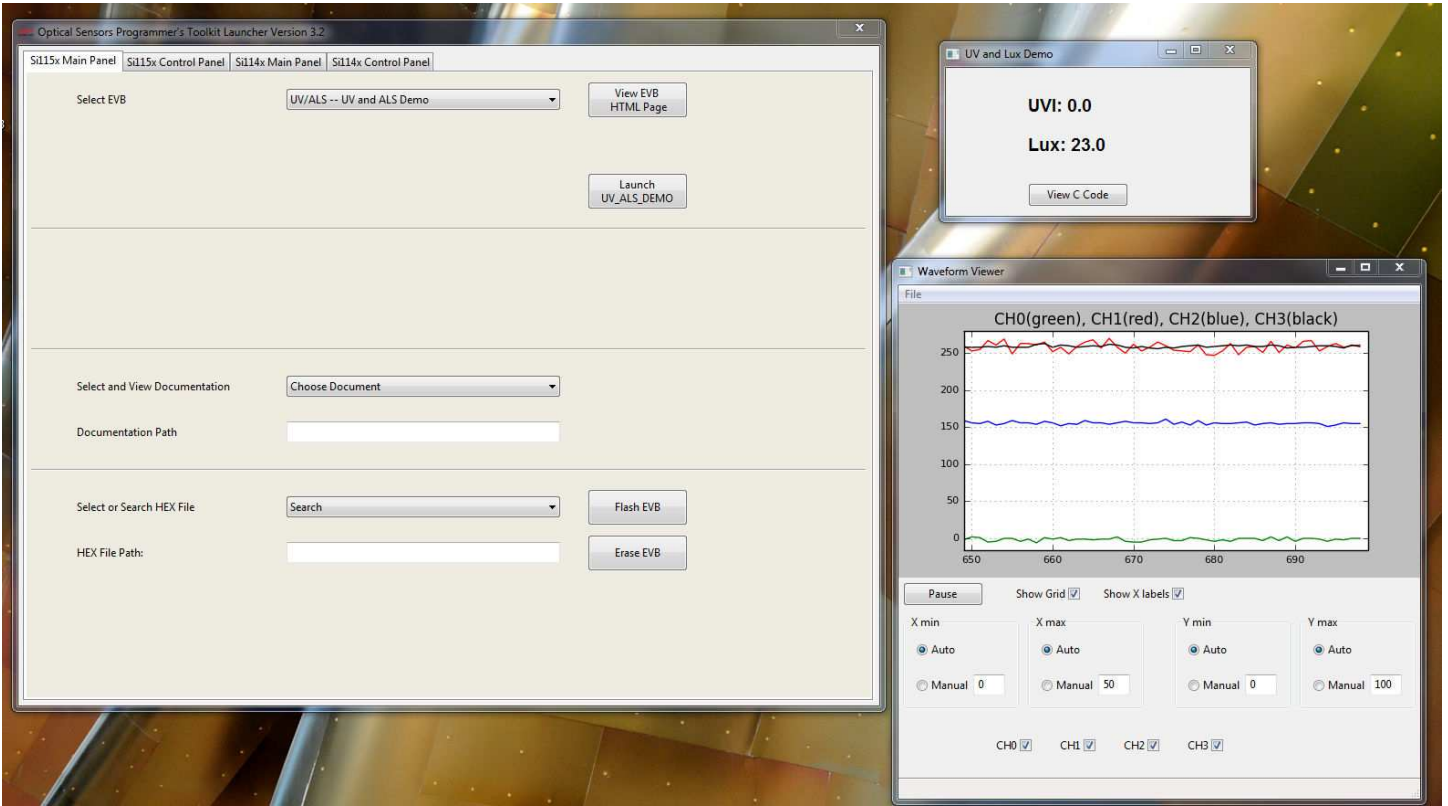

Figure 2.3. UV/ALS Demo Showing Measured Values and Raw Data Transferred on the I²C Bus

2.4 Using the Si1150 Control Panel in the Programmer's Toolkit

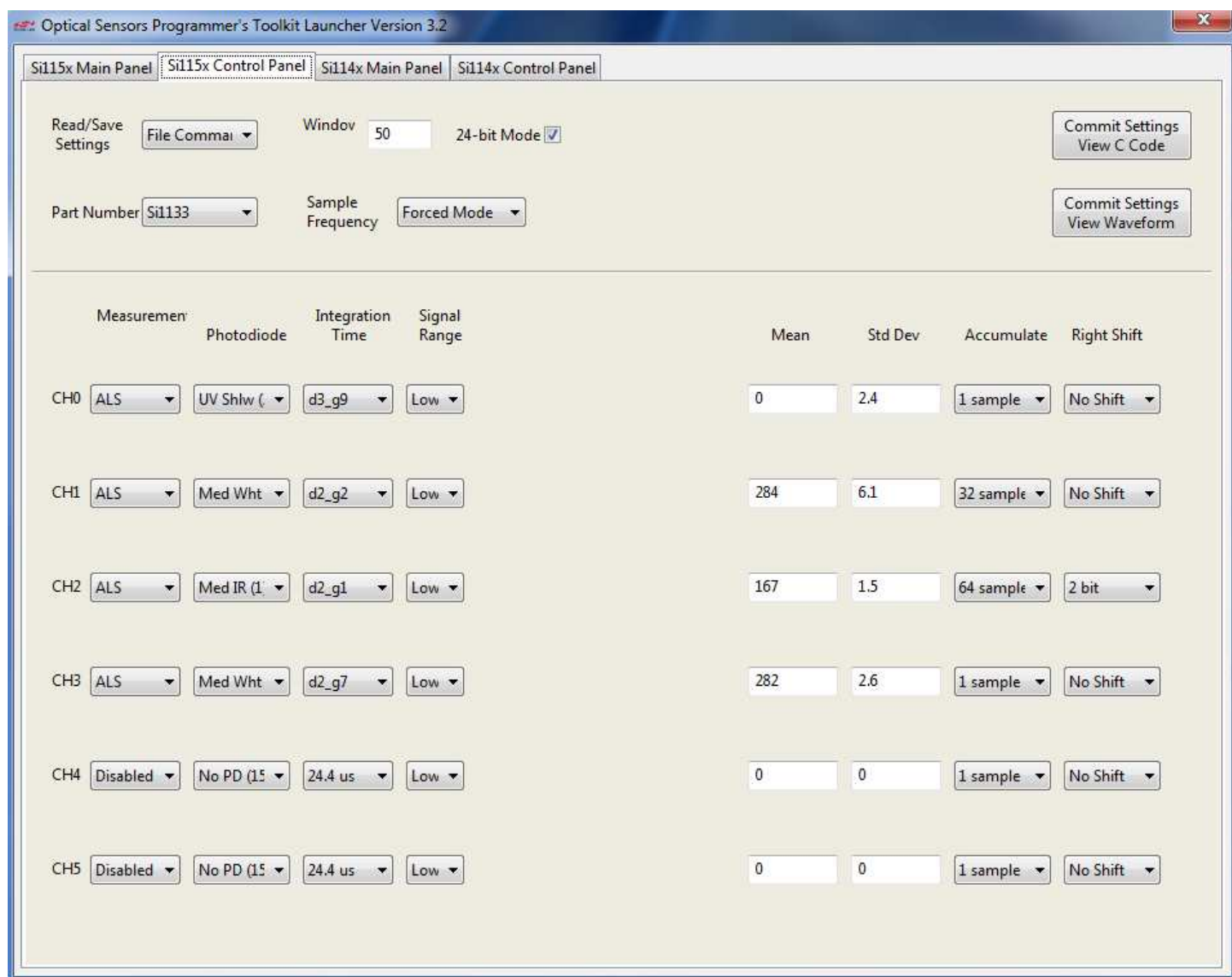

Figure 2.4. Si1150 Control Panel in the Programmer's Toolkit

The layout of the control panel mimics the programming registers described in the Datasheet. For example the parameter table allows the creation of up to six measurement tasks, each of which can be coupled to proximity ranging LEDs (or not). Each measurement task can be coupled to specific sensing photodiodes and associated integration time and range.

2.5 Simplicity Studio

Simplicity Studio will not include sample code to support the current evaluation board until Q2 2016. Users of this EVB can add their own code to Simplicity Studio projects.

3. The Five Sensors on the EVB

3.1 UV/ALS

The Si1133 sensor is mounted with a demonstration Teflon light diffuser assembly. The light opening behind the 1.6 mm diameter diffuser is a 0.8 mm diameter circle. The small size is preferred for the operation of the UV measurement and is an advantage for the customer.

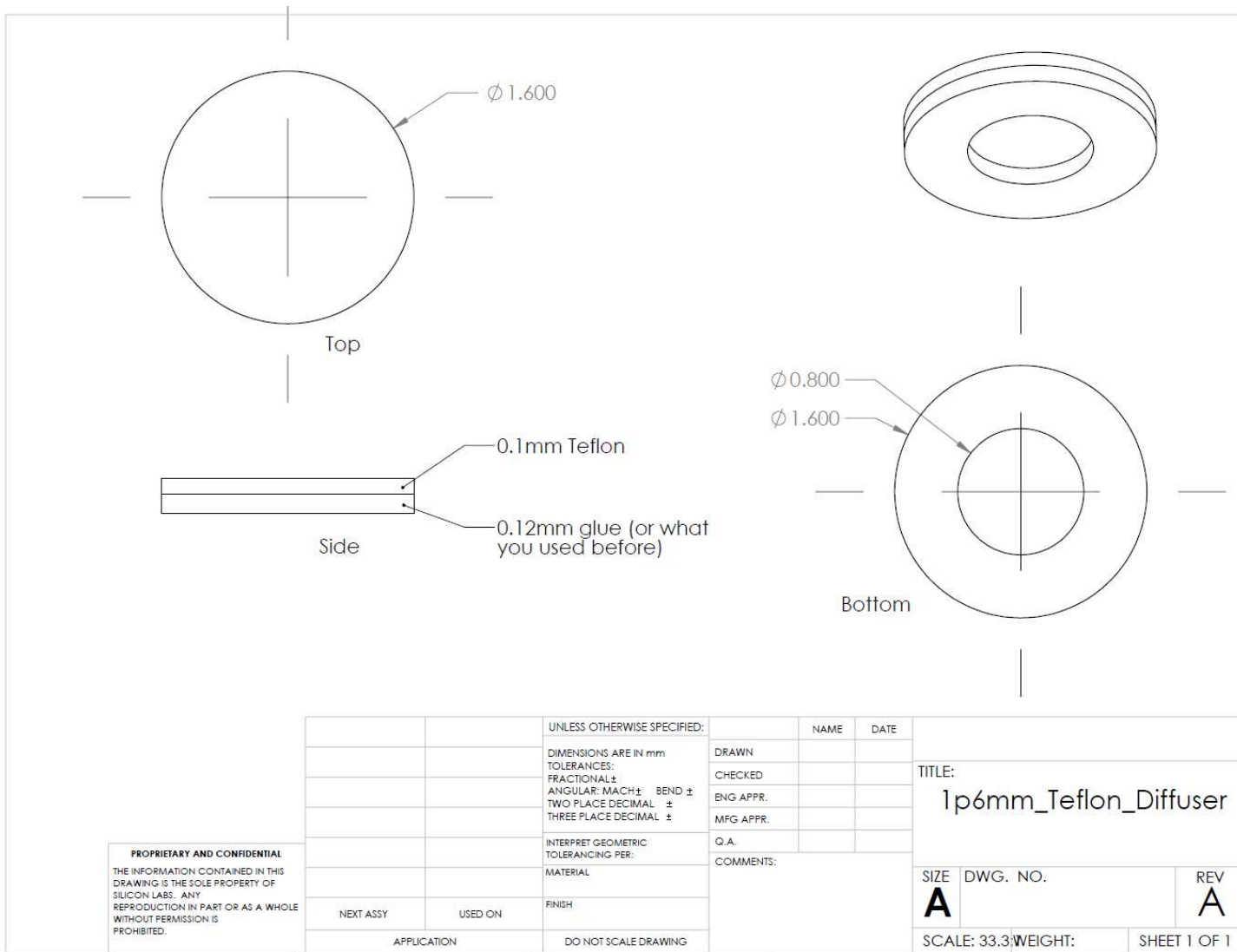

Figure 3.1. Teflon Diffuser

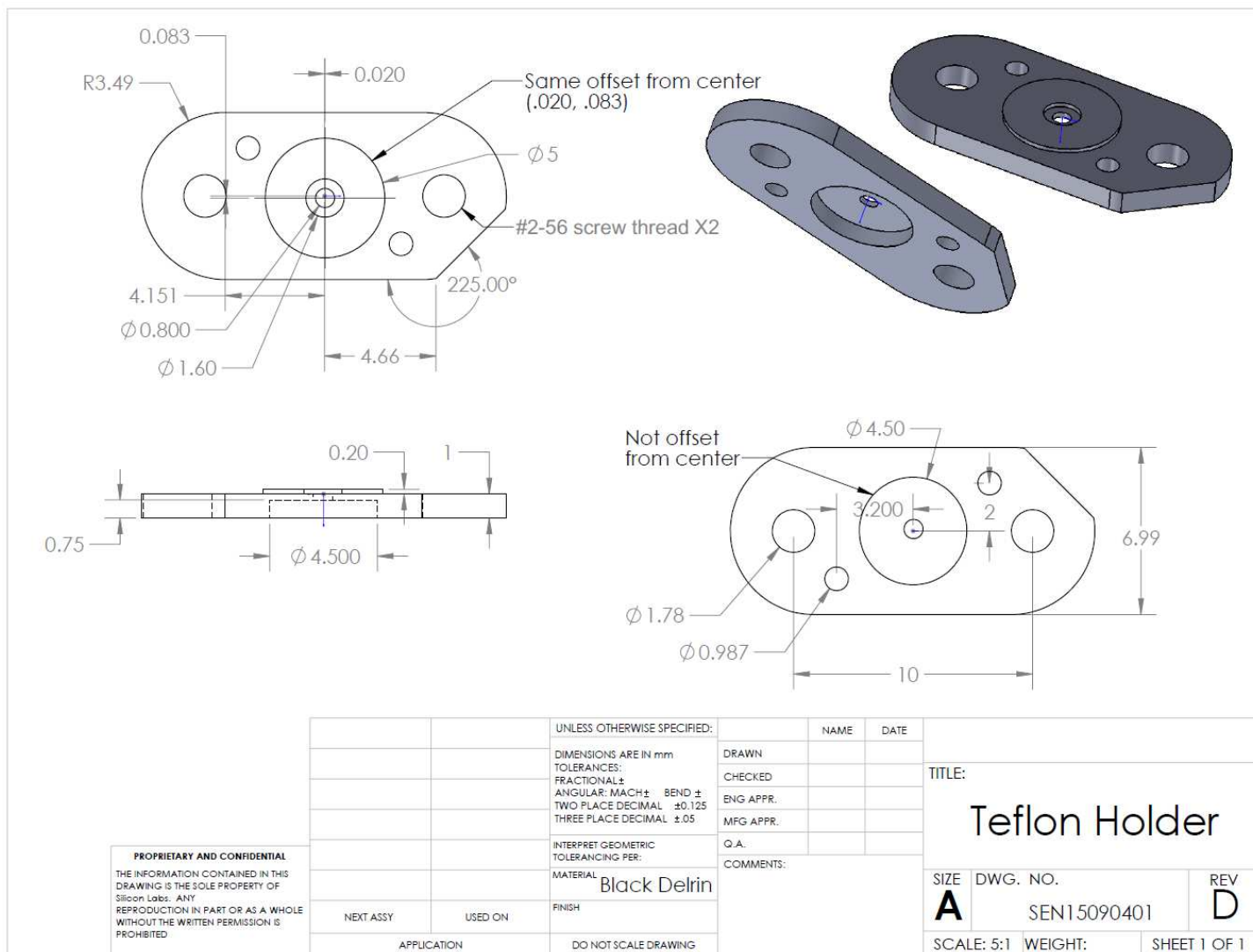

Figure 3.2. Teflon Diffuser Holder

The Teflon used is Porex™ PM6M material. For fabrication of Teflon into convenient glue-on, contact:

Craig Carroll

Sales Manager

Marian Fort Worth

1501 Northpark Dr.

Fort Worth, TX 76102

(817) 332-6151 x167

3.2 Long Range Proximity

The Si1153-AA09 2X2 mm proximity sensing chip with an on-die 940 nm bandpass filter for sunlight immunity. The Board demonstrates the use of a 5 mm dia. lens and arrow angle LED.

The 940 nm filter on the die and external LED are selected to coincide with a dip in solar energy that occurs around 940 nm. One gets the advantage of rejecting visible and IR light by a couple of orders of magnitude and operating in a safe area with minimal sun energy.

The lens is designed to give the sensor a roughly ± 5 degree field of view and so is the lensed LED chosen and mounted next to it on the PCB.

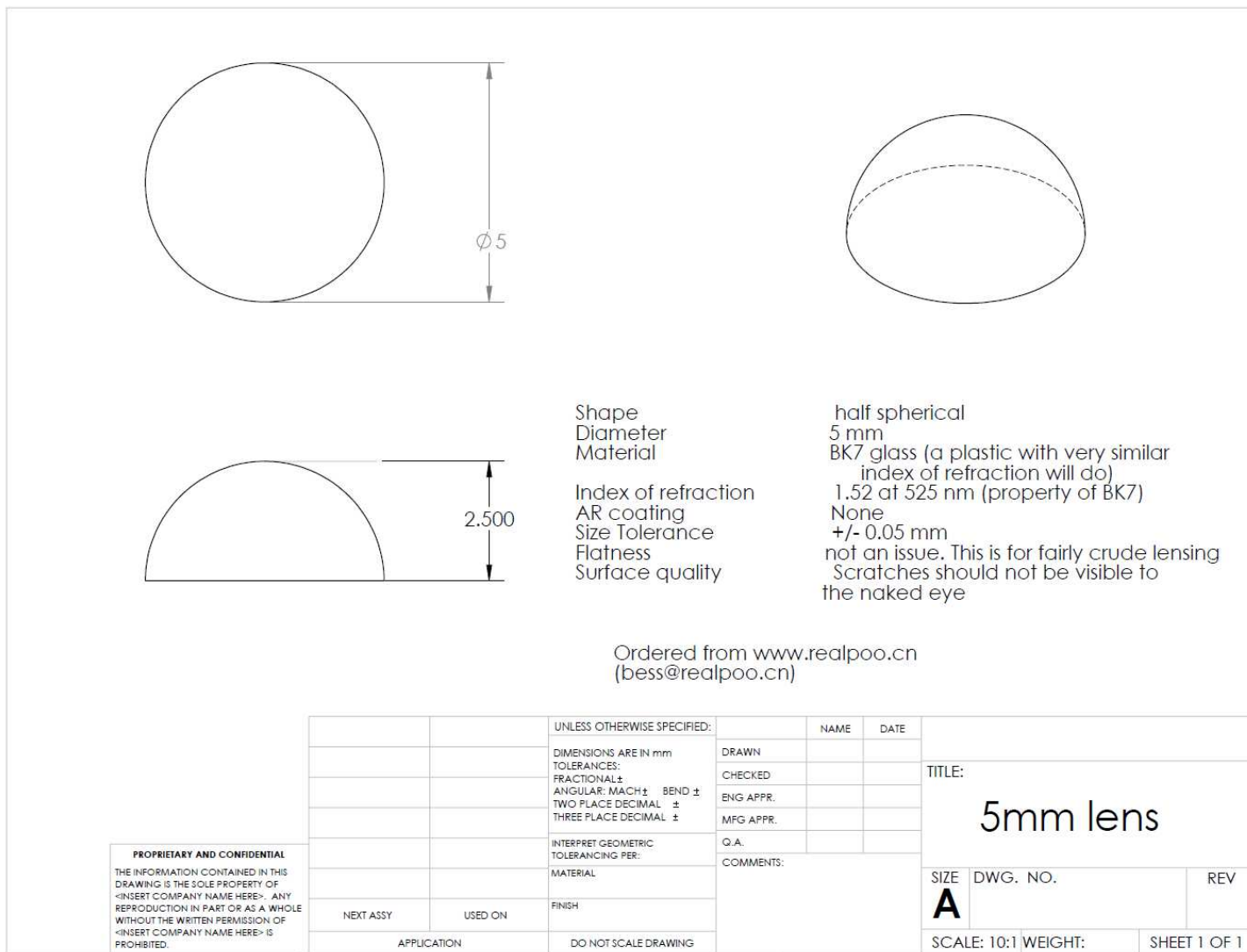

Figure 3.3. Lens Used for Long-Range Sensor

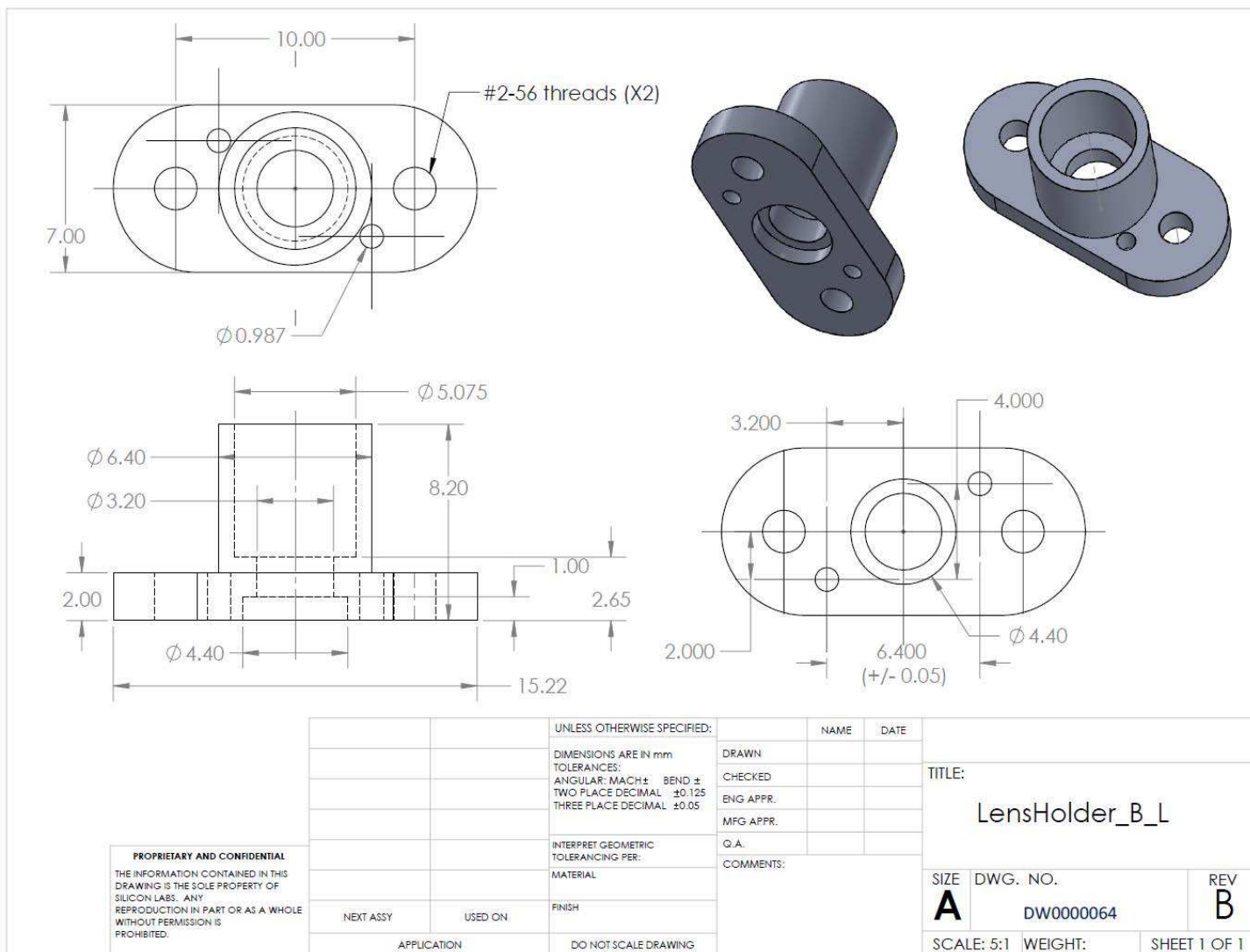

Figure 3.4. Lens Holder Used for Long-Range Sensor

3.3 Sunlight-Immune Proximity Module

A Si1153-AA09, 2.85 X 4.9 mm proximity sensing module with an on-die 940 nm bandpass filter for sunlight immunity and an integrated 940 nm LED is mounted on the board.

The 940 nm filter on the die and matching LED are selected to coincide with a dip in solar energy that occurs around 940 nm. One gets the advantage of rejecting visible and IR light by a couple of orders of magnitude and operating in a safe area with minimal sun energy.

3.4 Proximity/ALS

The Si1153-AA00, 2X2 mm light sensor chip is mounted with a nearby 850 nm LED to demonstrate simple ALS and proximity measurements.

3.5 Gesture/ALS

The Si1153-AA00 2x2 mm light sensor chip is mounted on the board, while the PCB uses three carefully spaced 850 nm LEDs for to demonstrate gesture operation.

4. Schematics

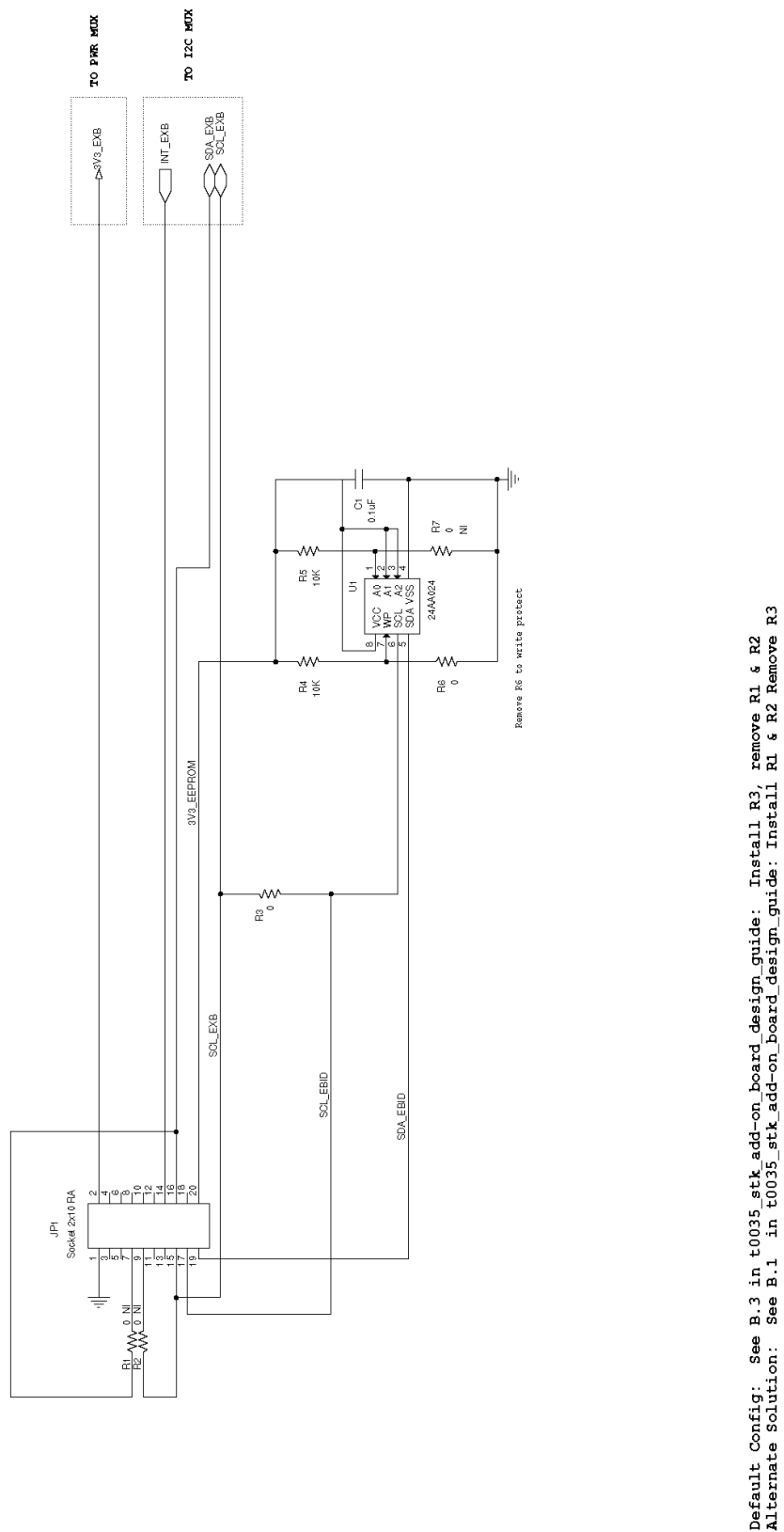

Figure 4.1. Schematic Page 1: Interface to the Gecko EVB Expansion Port

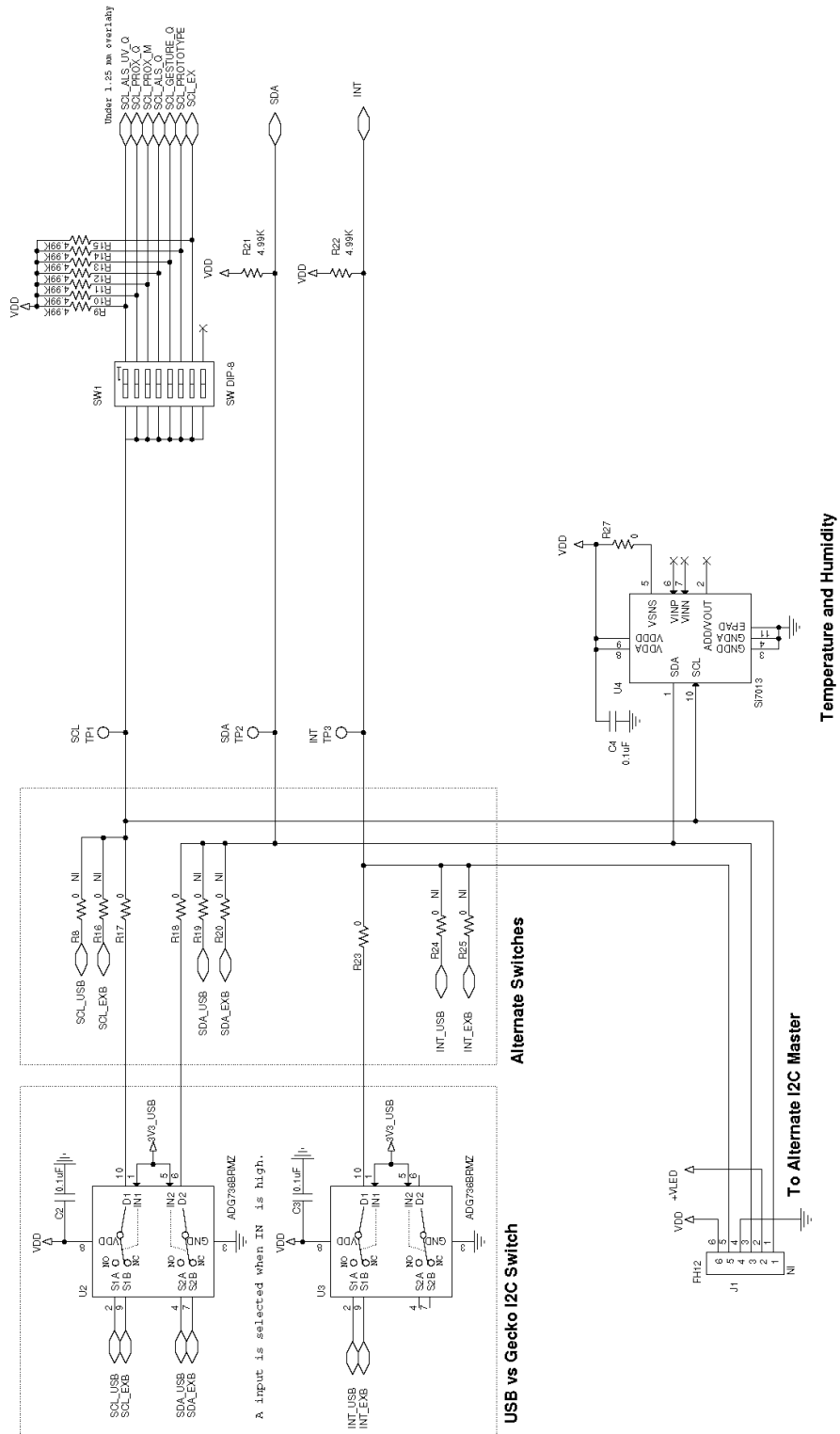

Figure 4.2. Schematic Page 2: I²C MUX, Sensor Selector Switch and Temperature/Humidity Sensor

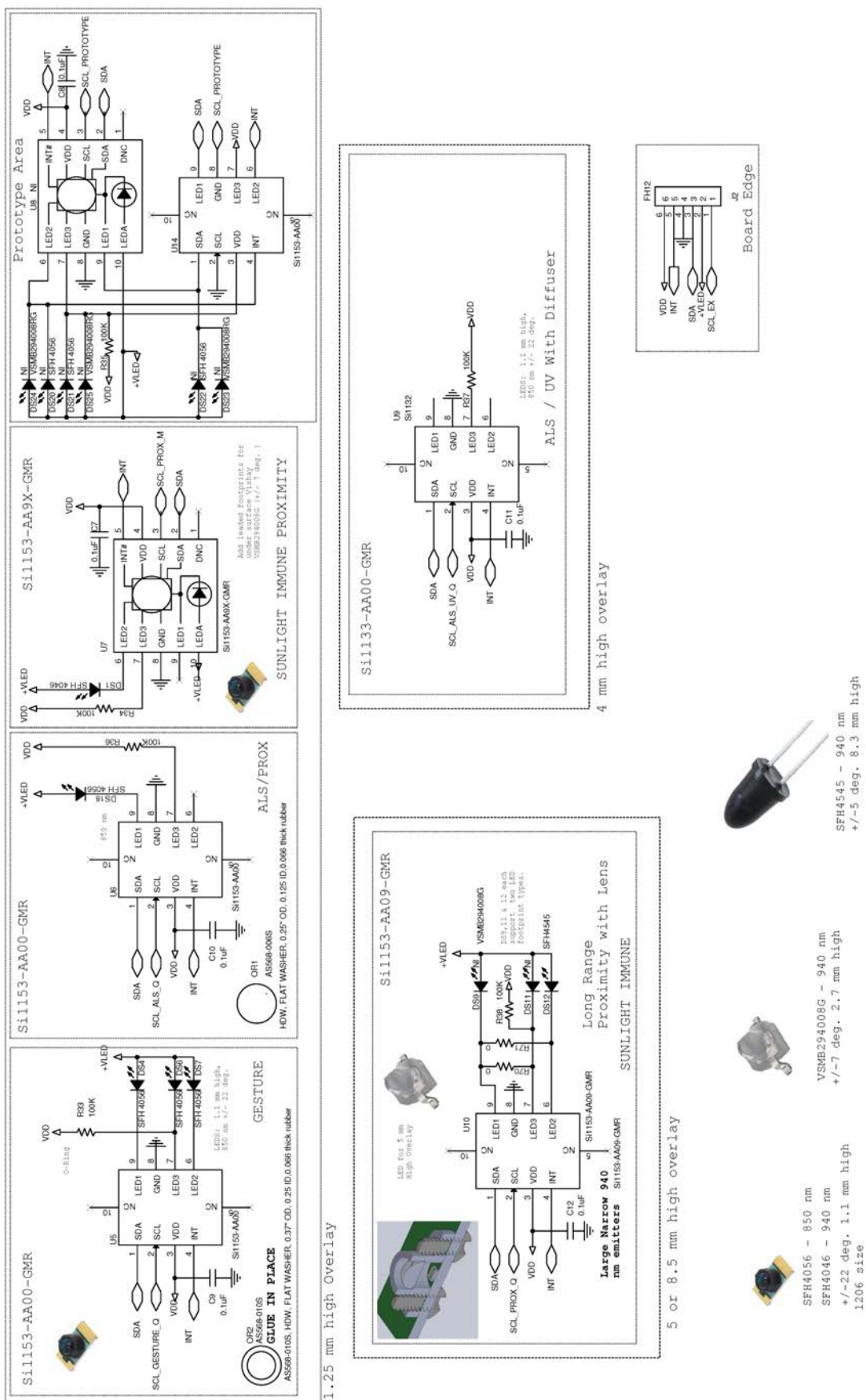

Figure 4.3. Schematic Page 3: Five Optical Sensors and One Prototype Area

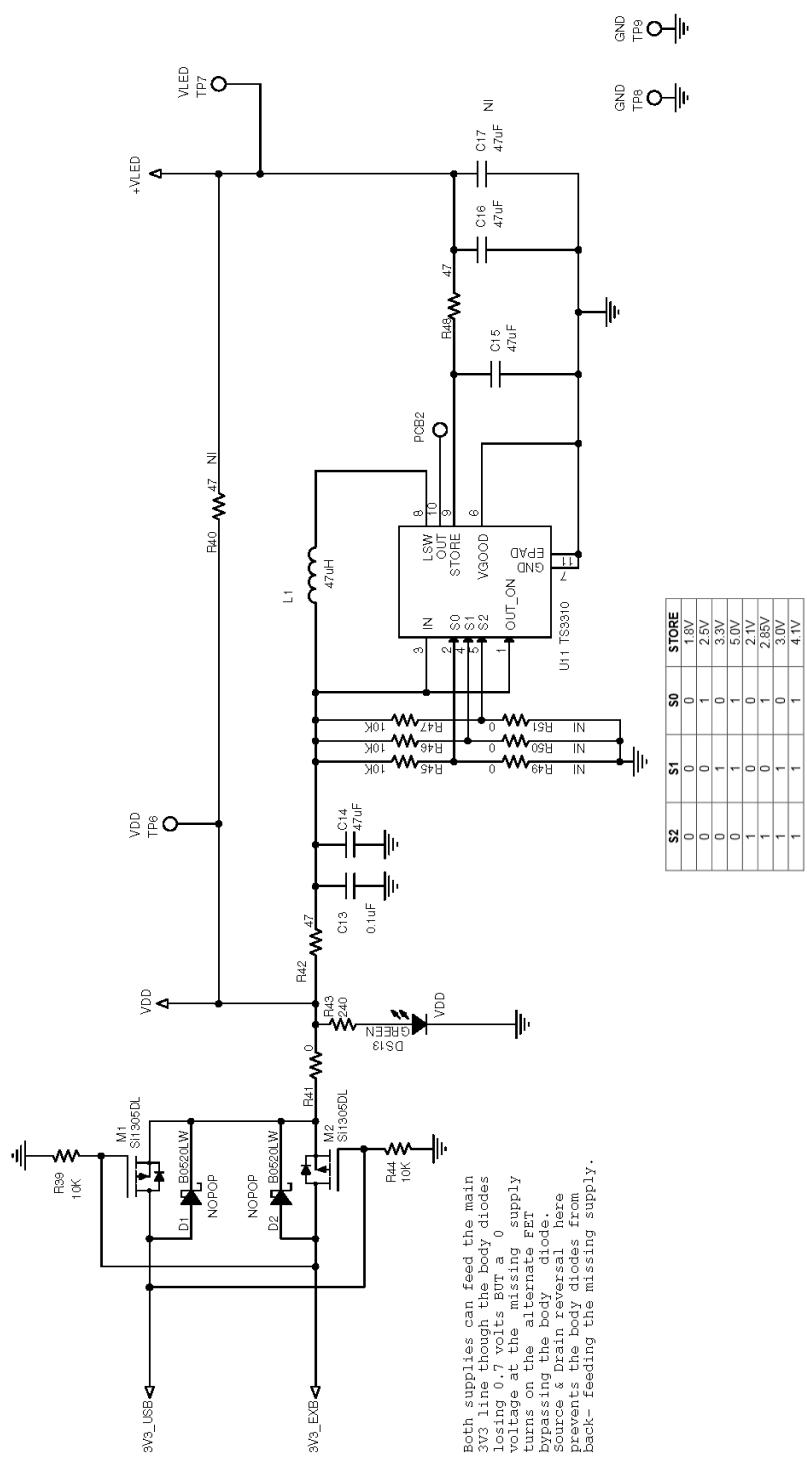

Figure 4.4. Schematic Page 4: Power Supply MUX and the VLED Up Converter

Note: Note that the up-converter is only needed if the VDD is less than 3.3 V. It is provided here for convenience if the user wants to evaluate operation with this converter.

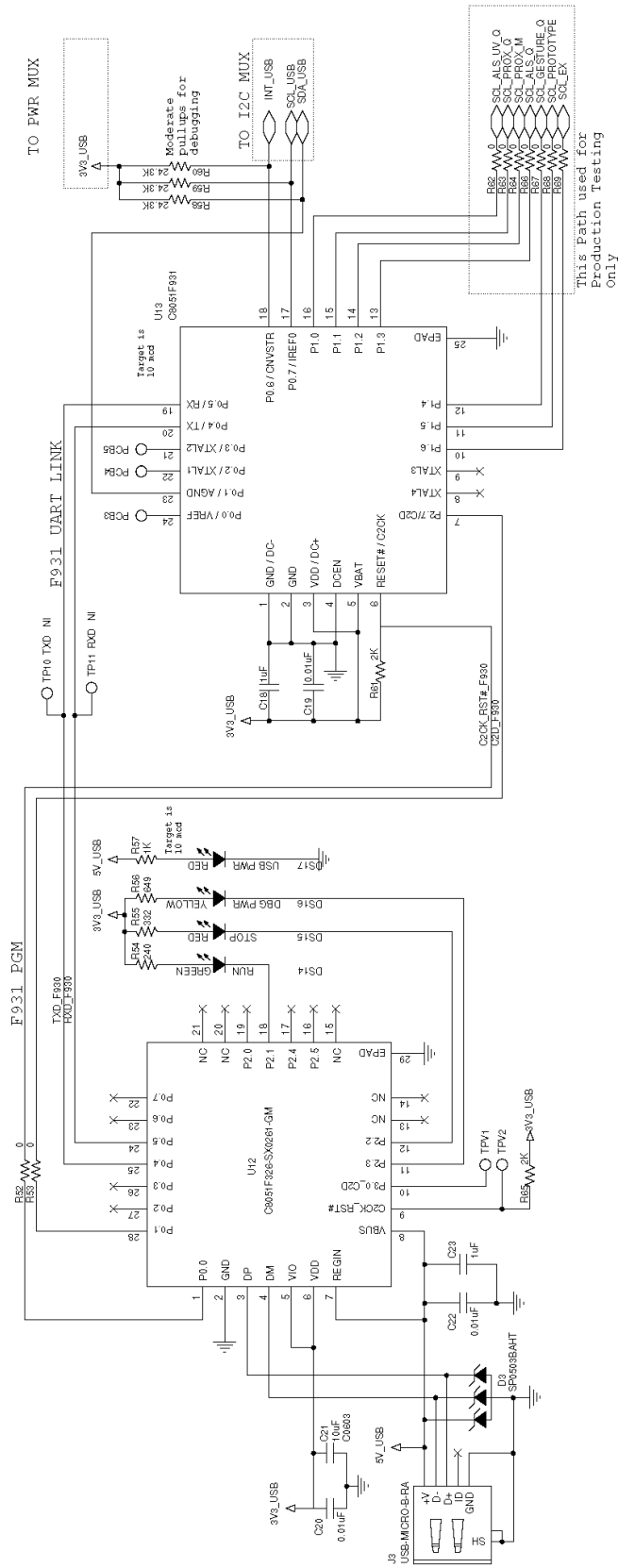

Figure 4.5. Schematic Page 5: USB Interface

5. PCB Layout

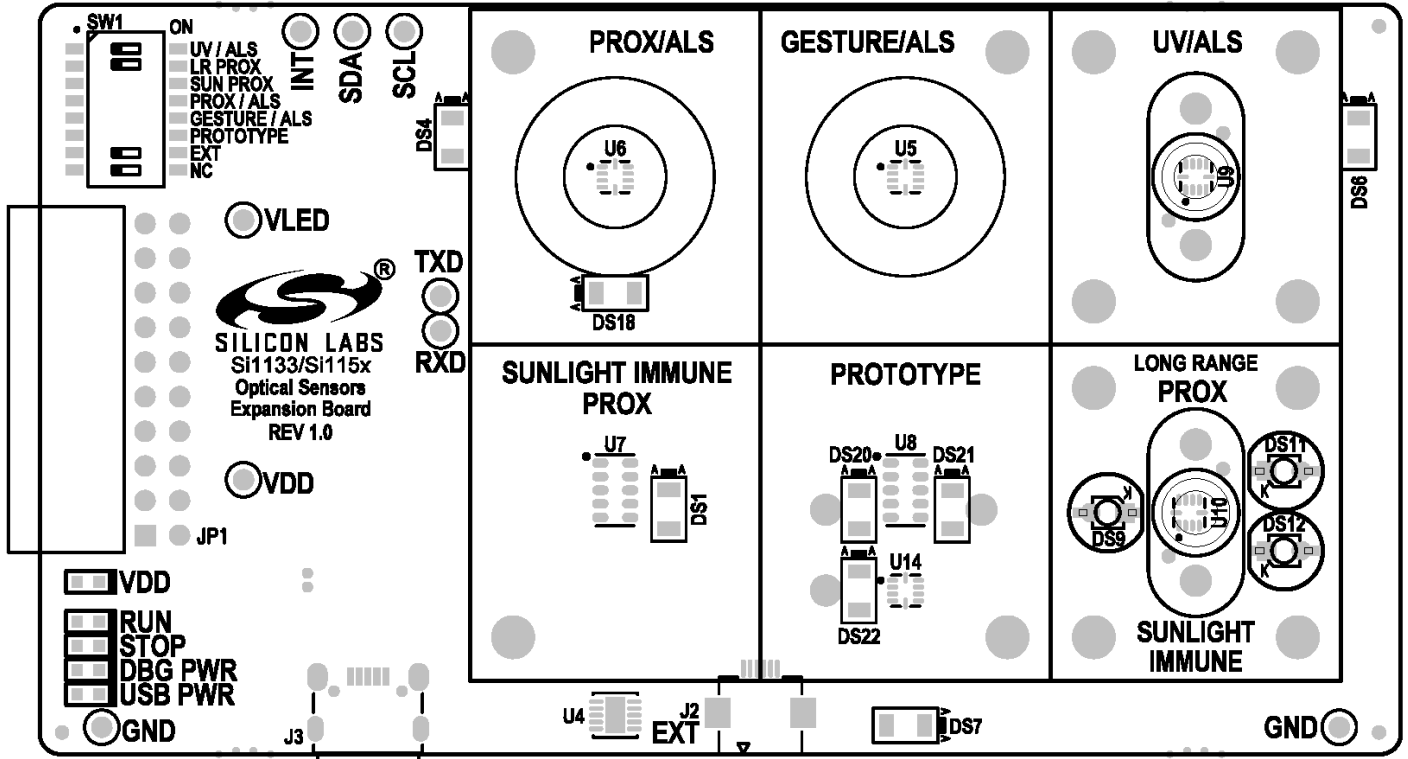

Figure 5.1. Primary Silk Screen

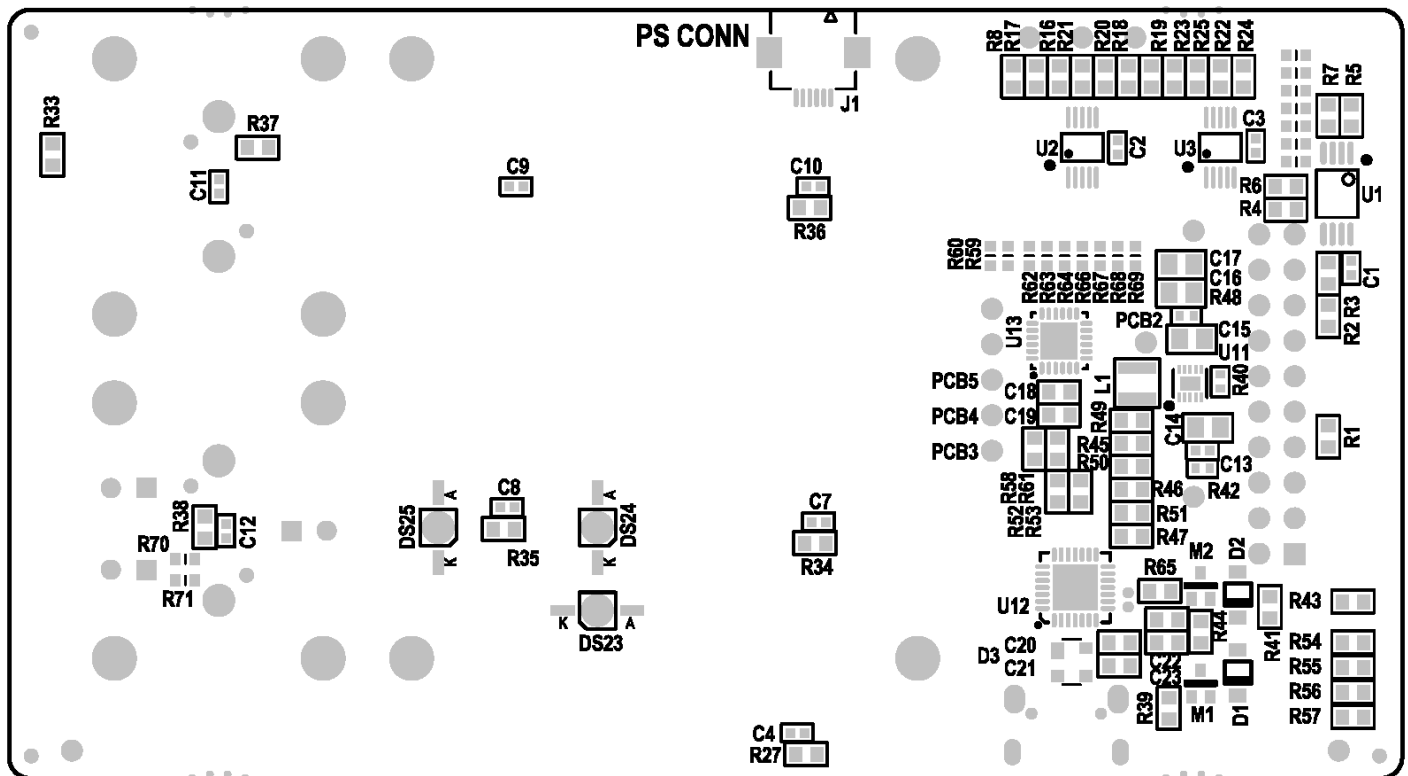

Figure 5.2. Secondary Silk Screen

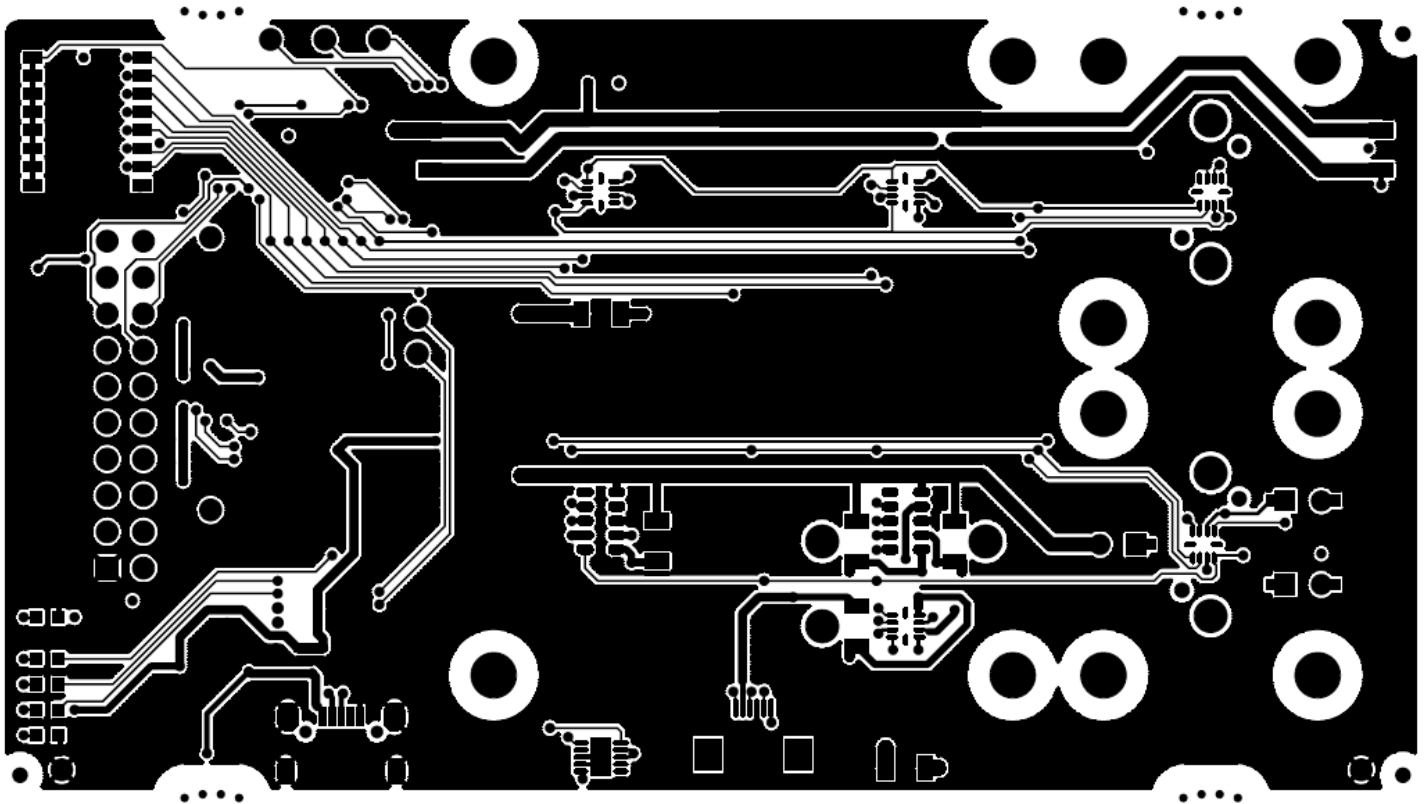

Figure 5.3. Primary Copper Layer

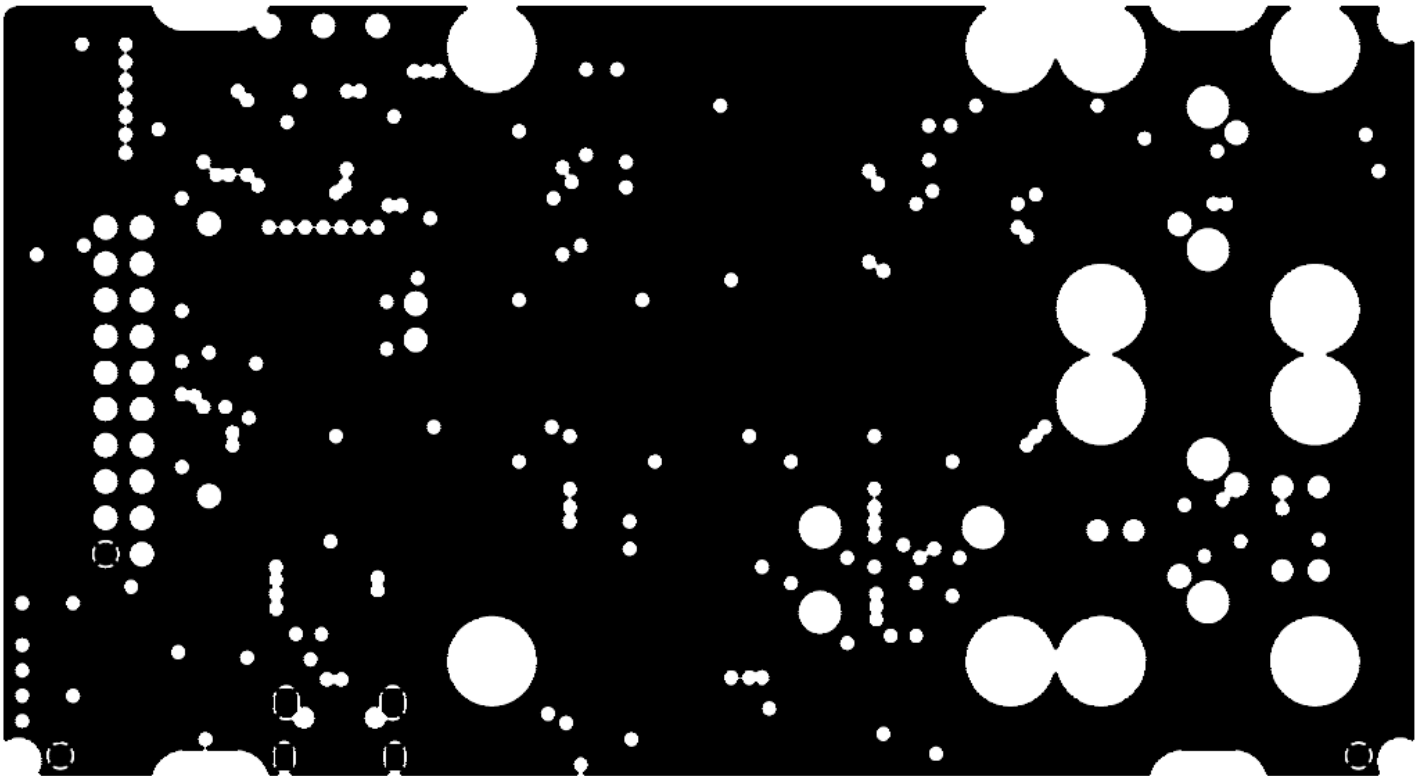

Figure 5.4. Copper Layer 2

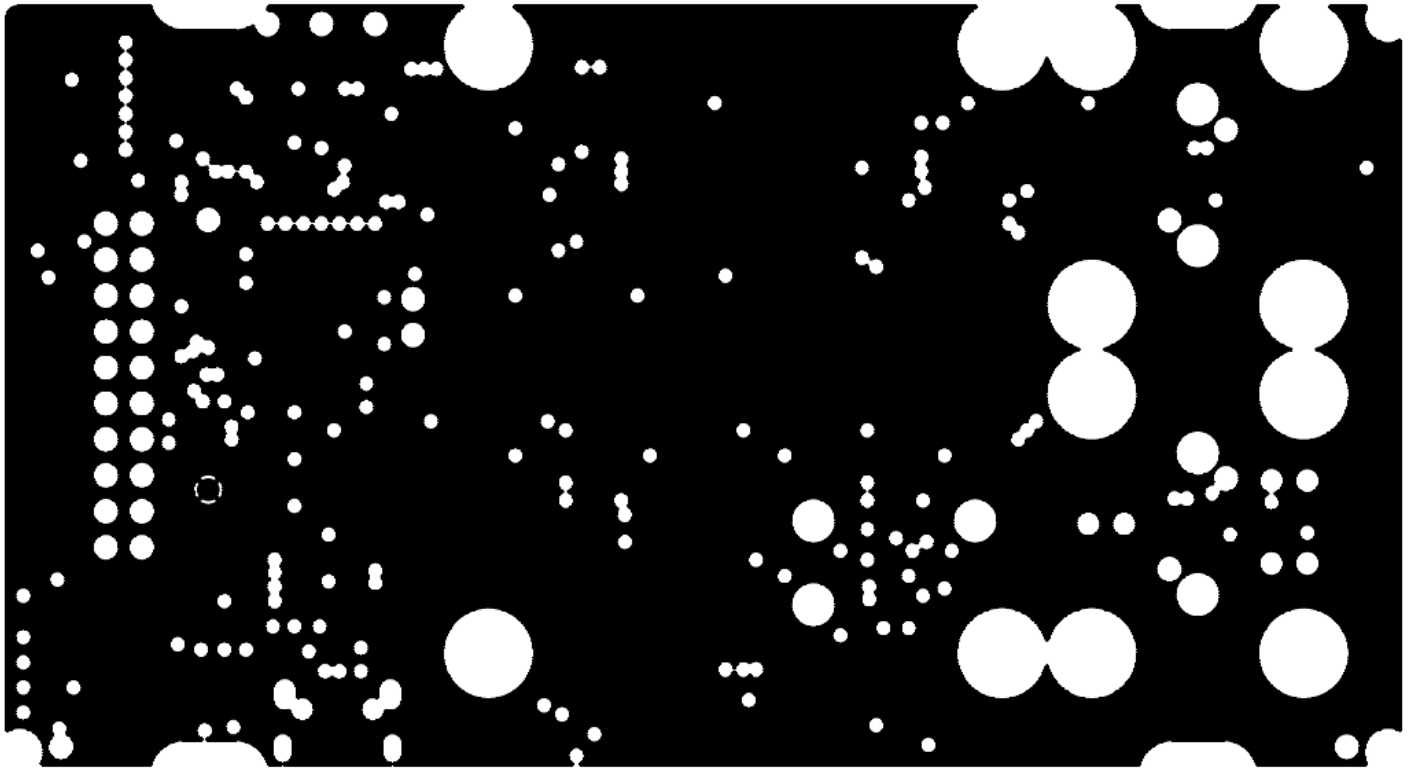

Figure 5.5. Copper Layer 3

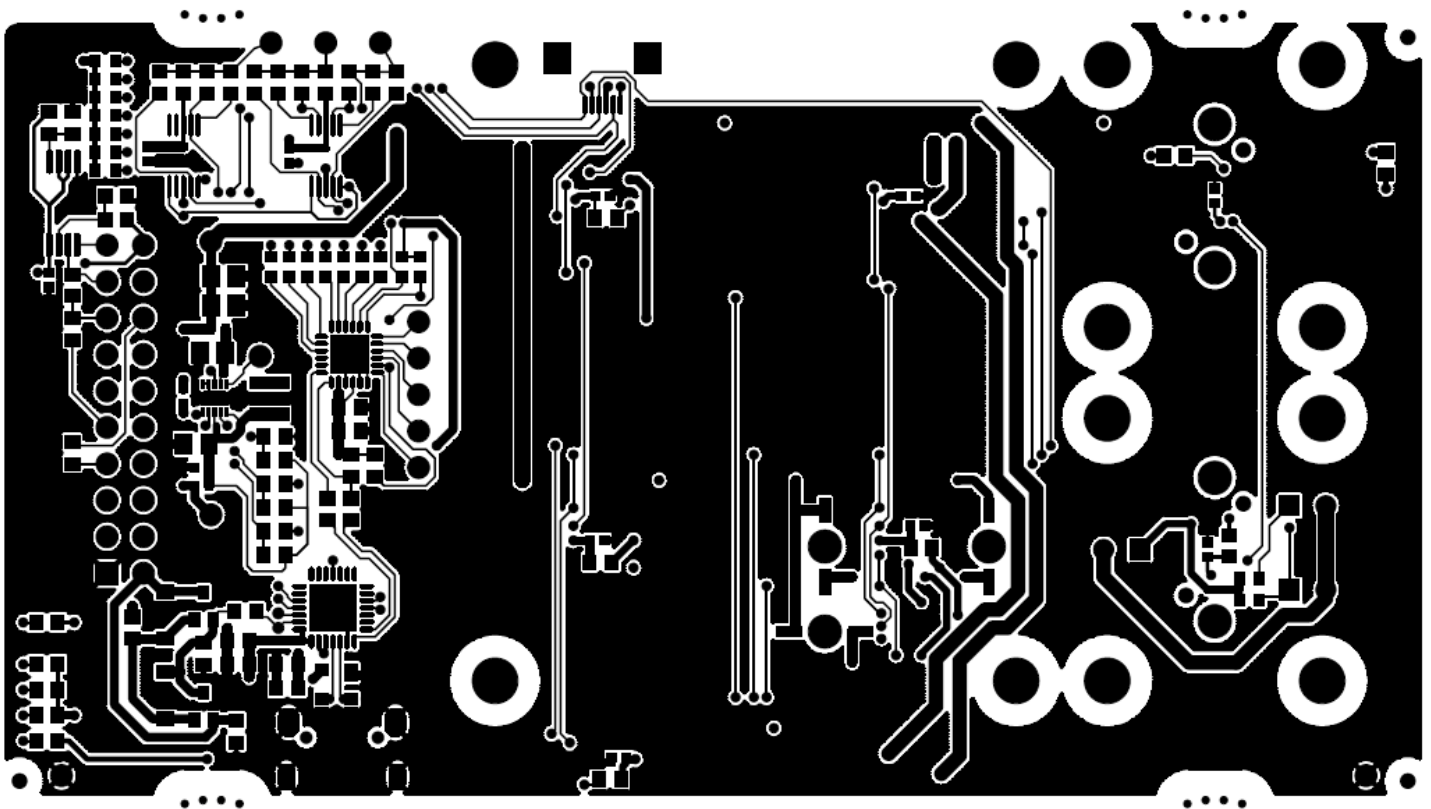

Figure 5.6. Copper Secondary Layer

6. Bill of Materials

Table 6.1. Si1133/Si115x-EVB Bill of Materials

Item	Not Installed	Qty	Ref	Value	Rating	Voltage	Tol	Type	PCB Footprint	Mfr
1		11	C1, C2, C3, C4, C7, C8, C9, C10, C11, C12, C13	0.1 μ F		10 V	\pm 10%	X7R	C0402X7R100-104K	Venkel
2		3	C14, C15, C16	47 μ F		6.3 V	\pm 20%	X5R	C0805X5R6R3-476M	Venkel
3	NI	1	C17	47 μ F		6.3 V	\pm 20%	X5R	C0805X5R6R3-476M	Venkel
4		2	C18, C23	1 μ F		10 V	\pm 10%	X7R	C0603X7R100-105K	Venkel
5		3	C19, C20, C22	0.01 μ F		10 V	\pm 20%	X7R	C0603X7R100-103M	Venkel
6		1	C21	10 μ F		6.3 V	\pm 20%	X5R	C0603X5R6R3-106M	Venkel
7		4	DOWEL1, DOWEL2, DOWEL3, DOWEL4	1 mm					91585A901	McMaster-Carr
8		1	DS1	940 nm				IR LED	SFH 4046	OSRAM
9		4	DS4, DS6, DS7, DS18	SFH 4056				SMT, IR LED	SFH 4056	OSRAM Opto Semiconductors Inc
10	NI	2	DS9, DS11	IR 940 nm				IR LED	VSMB294008G	Vishay
11		1	DS12	IR 940 nm				IR LED	SFH4545	OSRAM
12		2	DS13, DS14	Green					LTST-C190KGKT	Lite-on Technology Corp.
13		2	DS15, DS17	Red					LTST-C190KRKT	Lite-on Technology Corp.
14		1	DS16	Yellow					LTST-C190KSKT	Lite-on Technology Corp.
15	NI	3	DS20, DS21, DS22	SFH 4056				SMT, IR LED	SFH 4056	OSRAM Opto Semiconductors Inc.
16	NI	3	DS23, DS24, DS25	IR 940 nm				IR LED	VSMB294008RG	Vishay
17	NO-POP	2	D1, D2	B0520LW	500 mA	20 V		Schottky	B0520LW-7-F	Diodes Inc.
18		1	D3	SP0503BAHT	300 mW	20 V		TVS	SP0503BAHTG	Littlefuse
19		1	JP1	Socket 2x10 RA				Socket	SSW-110-02-G-D-RA	Samtec
20	NI	1	J1	FH12				FH12	FH12-6S-0.5SH(55)	Hirose
21		1	J2	FH12				FH12	FH12-6S-0.5SH(55)	Hirose

Item	Not Installed	Qty	Ref	Value	Rating	Voltage	Tol	Type	PCB Footprint	Mfr
22		1	J3	USB-MICRO-B-RA				USB		Würth
23		1	LENS1	5 mm					5MM_half_ball_bk7	Realpoo.cn
24		1	L1	47 μ H	250 mA		\pm 20%	Shielded	NR 3012T 470M	Taiyo Yuden
25	NI	3	MH1, MH3, MH4	Mount Hole				PCB Feature	MH-125NP	SiLabs
26	NI	1	MH2	Mounting_Hole-NP				PCB Feature	MH-125NP	SiLabs
27		4	MH5, MH6, MH7, MH8	Mount Hole				PCB Feature	MH-125NP	SiLabs
28		4	MH9, MH16, MH17, MH18	14702				HDW	H542-ND	B&F Fastener Supply
29	NI	8	MH13, MH19, MH28, MH29, MH30, MH31, MH32, MH33	14702				HDW	H542-ND	B&F Fastener Supply
30		4	MH27, MH34, MH35, MH36	20486				Screw	NY PMS 256 0025 PH	B&F Fastener
31		1	Mount1	8.25 mm High Lens Mount, (0.5 mm dia lens)				Overlay	TBD	Custom part at Penta Industries Inc.
32		1	Mount2	Si1133, 1mm high, Teflon Mount				Overlay	TBD	Various
33		2	M1, M2	Si1305DL	-0.86 A	-8 V		P-CHNL	Si1305DL	Vishay
34		4	NUT9, NUT10, NUT11, NUT12	14702				HDW	H616-ND	B&F Fastner
35		1	OR1	AS568-006S				HDW	AS568-006S	McMaster-Carr
36		1	OR2	AS568-010S				HDW	AS568-010S	McMaster-Carr
37		1	Overlay1	1.680" x 1.940" x 1/32"				Overlay	TBD	Various
38	NI	1	Overlay2	0.840" x 0.970" x 1/32"				Overlay	TBD	Various
39		4	PCB2, PCB3, PCB4, PCB5	PCB_PAD				PCB Feature	N/A	N/A
40	NI	12	R1, R2, R7, R8, R16, R19, R20, R24, R25, R49, R50, R51	0 Ω	1 A			Thick-Film	CR0603-16W-000	Venkel

Item	Not Installed	Qty	Ref	Value	Rating	Voltage	Tol	Type	PCB Footprint	Mfr
41		18	R3, R6, R17, R18, R23, R27, R41, R52, R53, R62, R63, R64, R66, R67, R68, R69, R70, R71	0 Ω	1 A			Thick-Film	CR0603-16W-000	Venkel
42		7	R4, R5, R39, R44, R45, R46, R47	10 kΩ	1/10 W		±5%	Thick-Film	CR0603-10W-103J	Venkel
43		9	R9, R10, R11, R12, R13, R14, R15, R21, R22	4.99 kΩ	1/16 W		±1%	Thick-Film	CR0603-16W-4991F	Venkel
44		6	R33, R34, R35, R36, R37, R38	100 kΩ	1/16 W		±5%	Thick-Film	CR0603-16W-104J	Venkel
45	NI	1	R40	47 Ω	1/16 W		±1%	Thick-Film	CR0402-16W-47R0F	Venkel
46		2	R42, R48	47 Ω	1/16 W		±1%	Thick-Film	CR0402-16W-47R0F	Venkel
47		2	R43, R54	240 Ω	1/16 W		±1%	Thick-Film	CR0603-16W-2400F	Venkel
48		1	R55	332 Ω	1/10 W		±1%	Thick-Film	CR0603-10W-3320F	Venkel
49		1	R56	649 Ω	1/10 W		±1%	Thick-Film	CR0603-10W-6490F	Venkel
50		1	R57	1 kΩ	1/16 W		±1%	Thick-Film	CR0603-16W-1001F	Venkel
51		3	R58, R59, R60	24.3 kΩ	1/16 W		±1%	Thick-Film	CR0603-16W-2432F	Venkel
52		2	R61, R65	2 kΩ	1/10 W		±1%	Thick-Film	CR0603-10W-2001F	Venkel
53	NI	4	ST1, ST2, ST3, ST4	14702				HDW	8440B	Keystone Electronics
54		1	SW1	SW DIP-8	0.025 A	24 V		DIP	TDA08H0SB1R	CTS
55		2	TPV1, TPV2	TPV				PCB Feature	N/A	N/A
56		7	TP1, TP2, TP3, TP6, TP7, TP8, TP9	Black				Loop	151-203-RC	Kobiconn
57	NI	2	TP10, TP11	Black				Loop	151-203-RC	Kobiconn
58		1	U1	24AA024		1.7 V		I ² C	24AA024-I/ST	Microchip
59		2	U2, U3	ADG736BRMZ				DUAL	ADG736BRMZ	Analog Devices

Item	Not Installed	Qty	Ref	Value	Rating	Voltage	Tol	Type	PCB Footprint	Mfr
60		1	U4	Si7013		+4.2 V		Sensor	Si7013-A20-GM1	SiLabs
61		3	U5, U6, U14	Si1153-AA00				ALS/ prox	Si1153-AA00-GMR	SiLabs
62		1	U7	Prox				Prox/ ALS	Si1153-AA9X-GMR	SiLabs
63	NI	1	U8	Ambient Light Sensor				Prox/ ALS	Si1143-M01-GM	SiLabs
64		1	U9	Si1132				UV/ALS	Si1133-AA00-GMR	SiLabs
65		1	U10	Si1153-AA09-GMR				Prox/ ALS	Si1153-AA09-GMR	SiLabs
66		1	U11	TS3310		5 V		Power	TS3310ITD1022	SiLabs
67		1	U12	C8051F326-SX0261-GM				MCU	C8051F326-SX0261-GM	SiLabs
68		1	U13	C8051F931				MCU	C8051F931-GM	SiLabs
69		4	WA10, WA11, WA12, WA13	Flat Washer #4				HDW	345	Keystone Electronics
70	NI	4	WA17, WA18, WA19, WA20	Flat Washer #4				HDW	3358	Keystone Electronics
71		1	WA21	0.1 mm thick Teflon				HDW	TBD	Marion Fort Worth, Teflon is Por-ex™ PM6M

7. Corrections

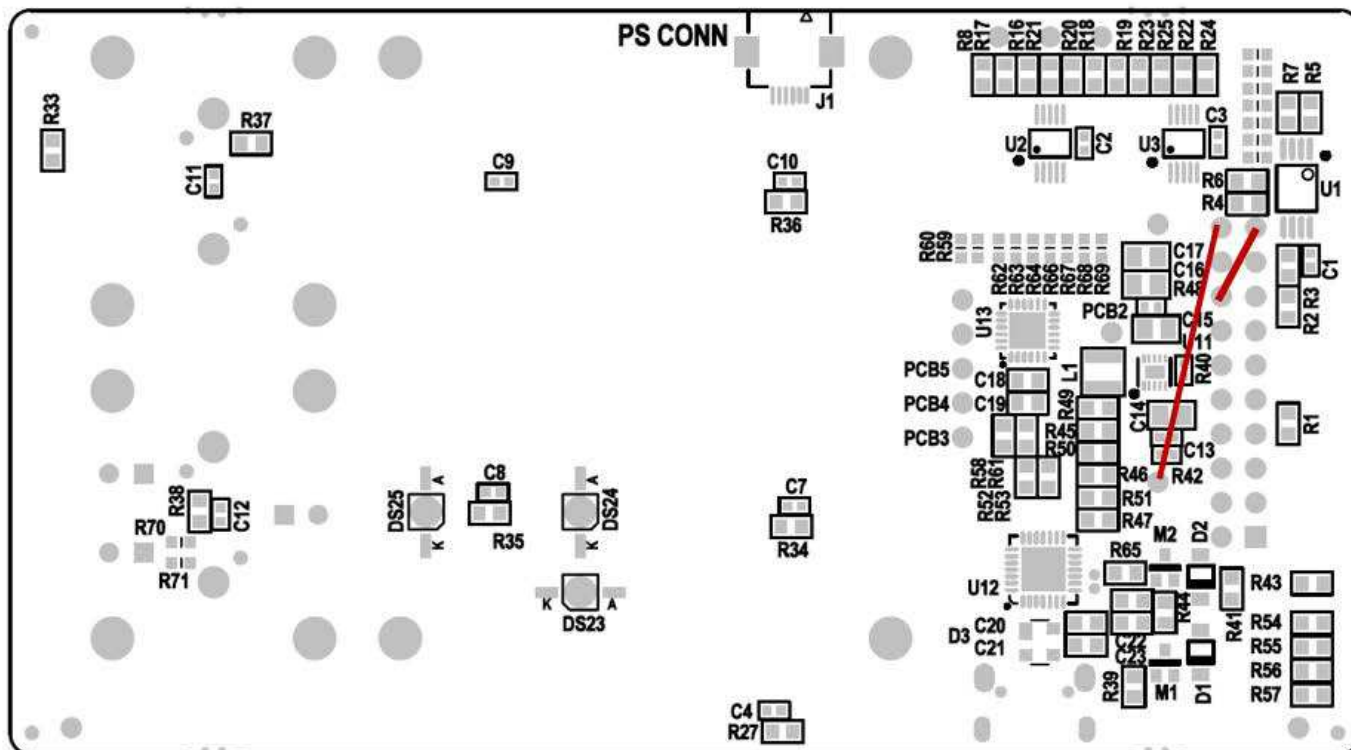

R1,2,7	NI	
R8, R16, R19	install 0 R Resistor	mux-bypass
R19, R20, R24	install 0 R Resistor	mux-bypass
R25	install 0 R Resistor	mux-bypass
R40	NI	POWER
R49, R50, R51	NI	<u>vled sel</u>
DS9	NI	alt LED
C17	NI	extra <u>decpl.</u>
R3	install 0R Resistor	<u>eeeprom path</u>
DS12	install SFH4545	
Wire	JP1.20 to VDD	
Wire	JP1.19 to JP1.16	

(FYI: Plastics that are screwed to PCB may melt in an oven).

Figure 7.1. Rework

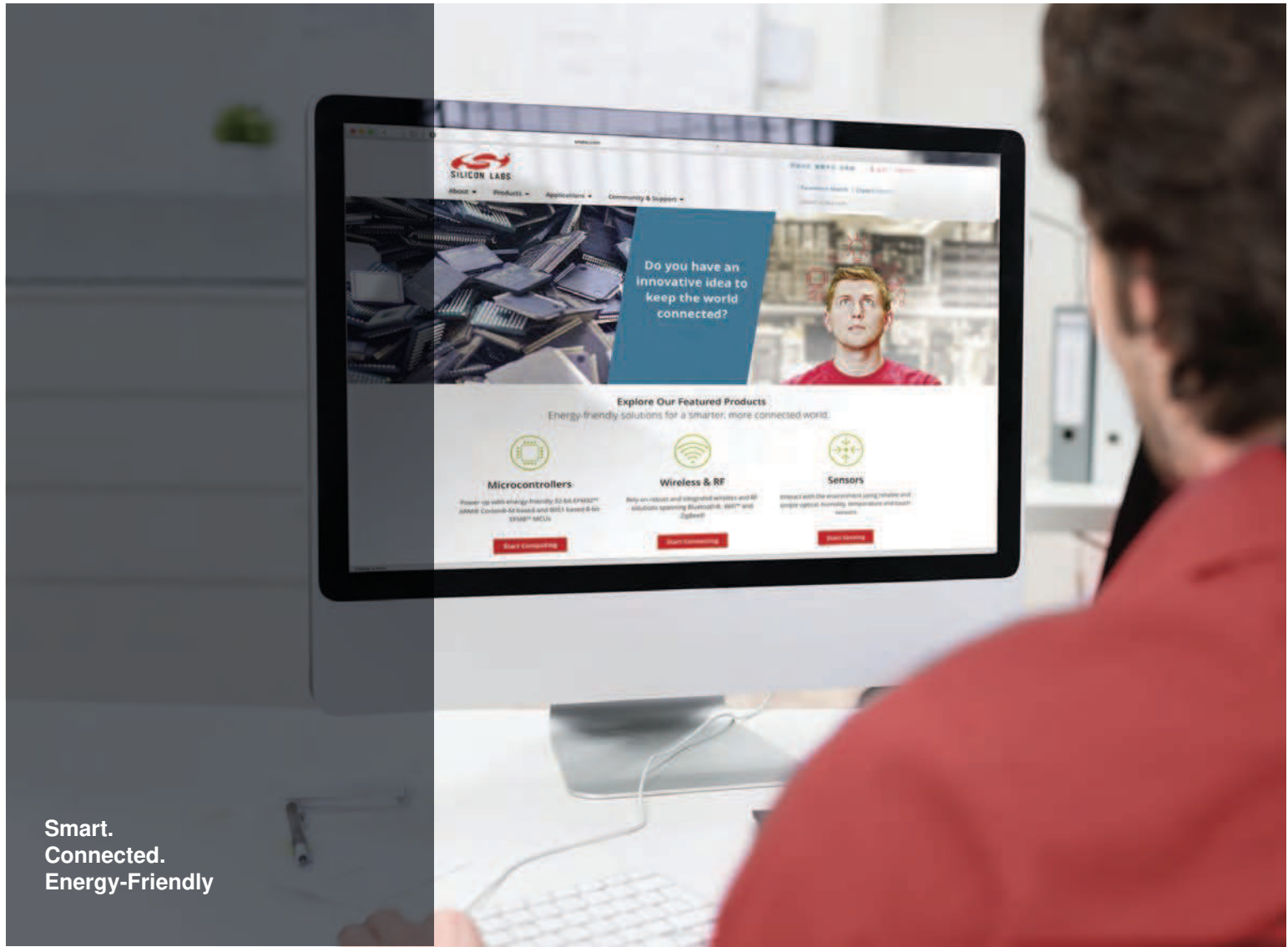

Smart.
Connected.
Energy-Friendly



Products
www.silabs.com/products

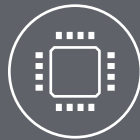

Quality
www.silabs.com/quality



Support and Community
community.silabs.com

Disclaimer

Silicon Laboratories intends to provide customers with the latest, accurate, and in-depth documentation of all peripherals and modules available for system and software implementers using or intending to use the Silicon Laboratories products. Characterization data, available modules and peripherals, memory sizes and memory addresses refer to each specific device, and "Typical" parameters provided can and do vary in different applications. Application examples described herein are for illustrative purposes only. Silicon Laboratories reserves the right to make changes without further notice and limitation to product information, specifications, and descriptions herein, and does not give warranties as to the accuracy or completeness of the included information. Silicon Laboratories shall have no liability for the consequences of use of the information supplied herein. This document does not imply or express copyright licenses granted hereunder to design or fabricate any integrated circuits. The products must not be used within any Life Support System without the specific written consent of Silicon Laboratories. A "Life Support System" is any product or system intended to support or sustain life and/or health, which, if it fails, can be reasonably expected to result in significant personal injury or death. Silicon Laboratories products are generally not intended for military applications. Silicon Laboratories products shall under no circumstances be used in weapons of mass destruction including (but not limited to) nuclear, biological or chemical weapons, or missiles capable of delivering such weapons.

Trademark Information

Silicon Laboratories Inc., Silicon Laboratories, Silicon Labs, SiLabs and the Silicon Labs logo, CMEMS®, EFM, EFM32, EFR, Energy Micro, Energy Micro logo and combinations thereof, "the world's most energy friendly microcontrollers", Ember®, EZLink®, EZMac®, EZRadio®, EZRadioPRO®, DSPLL®, ISOmodem®, Precision32®, ProSLIC®, SiPHY®, USBXpress® and others are trademarks or registered trademarks of Silicon Laboratories Inc. ARM, CORTEX, Cortex-M3 and THUMB are trademarks or registered trademarks of ARM Holdings. Keil is a registered trademark of ARM Limited. All other products or brand names mentioned herein are trademarks of their respective holders.



Silicon Laboratories Inc.
400 West Cesar Chavez
Austin, TX 78701
USA

<http://www.silabs.com>