



Chipsmall Limited consists of a professional team with an average of over 10 year of expertise in the distribution of electronic components. Based in Hongkong, we have already established firm and mutual-benefit business relationships with customers from,Europe,America and south Asia,supplying obsolete and hard-to-find components to meet their specific needs.

With the principle of “Quality Parts,Customers Priority,Honest Operation,and Considerate Service”,our business mainly focus on the distribution of electronic components. Line cards we deal with include Microchip,ALPS,ROHM,Xilinx,Pulse,ON,Everlight and Freescale. Main products comprise IC,Modules,Potentiometer,IC Socket,Relay,Connector.Our parts cover such applications as commercial,industrial, and automotives areas.

We are looking forward to setting up business relationship with you and hope to provide you with the best service and solution. Let us make a better world for our industry!



Contact us

Tel: +86-755-8981 8866 Fax: +86-755-8427 6832

Email & Skype: info@chipsmall.com Web: www.chipsmall.com

Address: A1208, Overseas Decoration Building, #122 Zhenhua RD., Futian, Shenzhen, China



RIGHTANGLE PLUG MALE

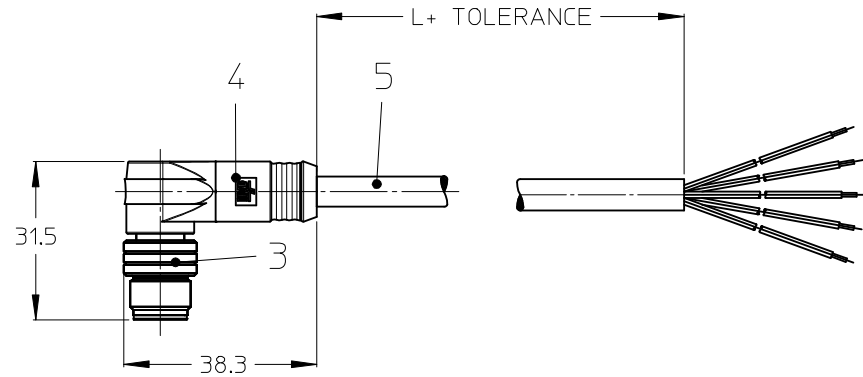
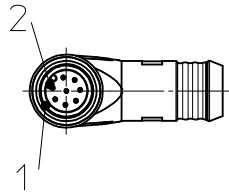

NOTES:

TEMPERATURE RANGE SEE TABLE ON PAGE 2

CONTACT CURRENT RATING 3-5 POLES 4A
8 POLES 2A

VOLTAGE RATING 3-4 POLES 250V
5 POLES 60V
8 POLES 30V

PROTECTION CLASS IP 67

TOLERANCES

≤ 1m +20/-10mm
1m - 5m ± 25mm
5m - 10m ± 30mm
> 10m ± 30mm
> 20m ± 50mm

3 WIRE	4 WIRE	5 WIRE	8 WIRE
PIN # WIRE 1 BROWN 2 - 3 BLUE 4 BLACK 5 -	PIN # WIRE 1 BROWN 2 WHITE 3 BLUE 4 BLACK 5 -	PIN # WIRE 1 BROWN 2 WHITE 3 BLUE 4 BLACK 5 GREY	PIN # WIRE 1 WHITE 2 BROWN 3 GREEN 4 YELLOW 5 GREY 6 PINK 7 BLUE 8 RED
REQUIRED TO IEC 60947-5-2		REQUIRED TO DIN 47100	

5	CABLE	SEE TABLE (PAGE 2)	---
4	OVERMOULDING	TPU	BLACK
3	MALE COUPLING NUT	BRASS	NI PLATED
2	PIN CONTACT	BRASS	GOLD PLATED
1	INSERT	PA	BLACK
ITEM	PART	MATERIAL	FINISH

ENTER DESCRIPTION EC NO: IPG2014-0972 DRW:FSCHAFHAUSER 2013/11/26 CHKD:PMERUNKA 2014/06/10 APPR:RSILLER 2014/06/18 2	DESCRIPTION QUALITY SYMBOLS ▽=0 ◻=0	GENERAL TOLERANCES (UNLESS SPECIFIED)		DIMENSION STYLE MM ONLY		SCALE 1:1	DESIGN UNITS METRIC	THIRD ANGLE PROJECTION
		4 PLACES ± --- ± --- 3 PLACES ± --- ± --- 2 PLACES ± 0.05 ± --- 1 PLACE ± 0.10 ± --- 0 PLACE ± --- ± ---	mm INCH ± --- ± --- ± 0.05 ± --- ± 0.10 ± --- ± --- ± ---	DRAWN BY PMERUNKA	DATE 2012/04/24	TITLE CSE M12 XP AC MA RA XM SE UNSH		
DRAFT WHERE APPLICABLE MUST REMAIN WITHIN DIMENSIONS		ANGULAR ± .5 °		APPROVED BY APOHL		DATE 2013/11/18	molex	
SEE TABLE				MATERIAL NO.		DOCUMENT NO. SD-120065-051		SHEET NO. 1 OF 4
THIS DRAWING CONTAINS INFORMATION THAT IS PROPRIETARY TO MOLEX INCORPORATED AND SHOULD NOT BE USED WITHOUT WRITTEN PERMISSION								

NUMERICAL CODE (Available parts see table page 3 ff others on request.)



80 = M12x1
single ended

poles:
3 = 3 poles
4 = 4 poles
5 = 5 poles

header:
000 = plug female straight
001 = plug female 90° right
006 = plug male straight
007 = plug male 90° right

M = meter
C = centimeter

length:
Example
020 = 2 m

Cable:
E02 = 0,25mm², PVC black
E03 = 0,34mm², PVC black
H08 = 0,25mm², PUR black LS0H
H09 = 0,34mm², PUR black LS0H
I03 = 0,34mm², PVC grey
K05 = 0,34mm², TPE yellow
P02 = 0,25mm², PUR/PVC black
P03 = 0,34mm², PUR/PVC black
P82 = 0,34mm², PUR black irradiated
P12 = 0,50mm², PVC black

CABLE TYPE	WIRE GAUGE	CABLE JACKET	UL	CSA	static	flexing	drag chain tested	other
E02	0.25mm²	PVC black	STYLE 2464	I/II A/B 80°/300V	-30°C to +80°C 5xD	-5°C to +80°C 9xD	---	---
E03	0.34mm²	PVC black	STYLE 2464	I/II A/B 80°/300V	-30°C to +80°C 5xD	-5°C to +80°C 9xD	---	---
H08	0.25mm²	PUR black LS0H	AWM STYLE 21198/10493	APPROVED	-50°C to +80°C 5xD	-25°C to +80°C 10xD	2000000 cycles	---
H09	0.34mm²	PUR black LS0H	AWM STYLE 21198/10493	APPROVED	-50°C to +80°C 5xD	-25°C to +80°C 10xD	drag chain 60°C	---
I03	0.34mm²	PVC grey	---	---	-30°C to +70°C	-5°C to +70°C	---	---
K05	0.34mm²	TPE yellow	ITC E195601 or PLTC	AWM I/II A/B FT4 LL54185	---	---	---	CSA-US:ITC LL54185-02
P02	0.25mm²	PUR/PVC black	not applicable	not applicable	-30°C to +80°C 7xD	-5°C to +80°C 15xD	---	---
P03	0.34mm²	PUR/PVC black	not applicable	not applicable	-30°C to +80°C 7xD	-5°C to +80°C 15xD	---	---
P82	0.34mm²	irrad. PUR orange	---	---	-50°C to +105°C 5xD	-40°C to +105°C 7.5xD	---	---
P12	0.50mm²	PVC black	---	---	-30°C to +90°C	-5°C to +90°C	---	---

B B

ENTER DESCRIPTION EC NO: IPG2014-0972 DRW:NFSCHAFHAUSER 2013/11/26 CHKD:PMERUNKA 2014/06/10 APPR:RSILLER 2014/06/18	QUALITY SYMBOLS ▽=0 ◻=0	GENERAL TOLERANCES (UNLESS SPECIFIED)		DIMENSION STYLE MM ONLY		SCALE 1:1	DESIGN UNITS METRIC	THIRD ANGLE PROJECTION		
		4 PLACES ± --- ± --- 3 PLACES ± --- ± --- 2 PLACES ± 0.05 ± --- 1 PLACE ± 0.10 ± --- 0 PLACE ± --- ± ---		DRAWN BY PMERUNKA	DATE 2012/04/24	TITLE CSE M12 XP AC MA RA XM SE UNSH				
		ANGULAR ± .5 °		CHECKED BY RSILLER	DATE 2013/01/18	<div style="text-align: center; font-size: 2em; font-weight: bold;">molex</div>				
		DRAFT WHERE APPLICABLE MUST REMAIN WITHIN DIMENSIONS		APPROVED BY APOHL	DATE 2013/11/18					

	10	9	8	7	6	5	4	3	2	1	
	PART NUMBER	NUMERICAL CODE	CABLE LENGTH "L" IN M	PART NUMBER	NUMERICAL CODE	CABLE LENGTH "L" IN M	PART NUMBER	NUMERICAL CODE	CABLE LENGTH "L" IN M		
F	1200658567	803007E03M010	1M	1200658603	804007I03M030	3M	1200658749	805007H09M015	1.5M		
	1200060273	803007E03M020	2M	1200658604	804007I03M040	4M	1200658750	805007H09M020	2M		
	1200658568	803007E03M030	3M	1200651686	804007K03M005	0.5M	1200658751	805007H09M030	3M		
	1200658569	803007E03M040	4M	1200651687	804007K03M020	2M	1200658752	805007H09M040	4M		
	1200060275	803007E03M050	5M	1200651688	804007K03M050	5M	1200658753	805007H09M050	5M		
	1200658506	803007E03M100	10M	1200651689	804007K03M060	6M	1200658754	805007H09M100	10M		
	1200658720	803007H09M010	1M	1200652026	804007K03M100	10M	1200658327	805007I03M015	1.5M		
	1200658721	803007H09M015	1.5M	1200651690	804007K05M006	0.6M	1200652159	805007K03M020	2M		
	1200658722	803007H09M020	2M	1200651691	804007K05M020	2M	1200652160	805007K03M040	4M		
	1200658723	803007H09M030	3M	1200651692	804007K05M040	4M	1200652161	805007K03M050	5M		
	1200658724	803007H09M040	4M	1200651693	804007K05M050	5M	1200652162	805007K03M060	6M		
E	1200658725	803007H09M050	5M	1200651694	804007K05M060	6M	1200652163	805007K03M100	10M		
	1200658726	803007H09M100	10M	1200651695	804007K05M100	10M	1200060695	805007P03M010	1M		
	1200658596	803007I03M010	1M	1200010093	804007P03M003W	0.3M	1200060696	805007P03M015	1.5M		
	1200658597	803007I03M040	4M	1200064178	804007P03M005	0.5M	1200060697	805007P03M020	2M		
	1200658598	803007I03M100	10M	1200010094	804007P03M006W	0.6M	1200060699	805007P03M040	4M		
	1200651501	803007K05M020	2M	1200061764	804007P03M010	1M	1200658186	805007P03M050	5M		
	1200651502	803007K05M040	4M	1200010095	804007P03M010W	1M	1200652149	805007P03M060	6M		
	1200651503	803007K05M050	5M	1200010096	804007P03M015W	1.5M	1200655006	805007P03M100	10M		
	1200651504	803007K05M060	6M	1200060592	804007P03M020	2M	1200658521	805007P12M006	0.6M		
	1200651505	803007K05M100	10M	1200064394	804007P03M020G	2M	1200062304	805007P12M015	1.5M		
D	1200658615	803007P03M010	1M	1200010097	804007P03M020W	2M	1200658522	805007P12M020	2M		
	1200060288	803007P03M020	2M	1200060593	804007P03M030	3M	1200658549	808007E02M020	2M		
	1200060289	803007P03M030	3M	1200010098	804007P03M030W	3M	1200658580	808007E03M010	1M		
	1200658614	803007P03M040	4M	1200652145	804007P03M040	3M	1200658581	808007E03M030	3M		
	1200062055	803007P03M050	5M	1200060594	804007P03M050	4M	1200658582	808007E03M040	4M		
	1200658618	803007P03M100	10M	1200010099	804007P03M050W	5M	1200658583	808007E03M050	5M		
	1200062638	804007E03M006	0.6M	1200652146	804007P03M060	5M	1200658584	808007E03M100	10M		
	1200060582	804007E03M010	1M	1200060595	804007P03M100	6M	1200658755	808007H08M010	1M		
	1200062680	804007E03M0101	1.01M	1200010102	804007P03M200W	10M	1200658756	808007H08M015	1.5M		
C	1200061975	804007E03M020	2M	1200010796	804007P03M500W	20M	1200658757	808007H08M020	2M		
	1200062681	804007E03M0201	2.01M	1200658005	804007P82M010	50M	1200658758	808007H08M030	3M		
	1200060583	804007E03M030	3M	1200655015	804007P82M050	1M	1200658759	808007H08M040	4M		
	1200658572	804007E03M040	4M	1200655016	804007P82M100	5M	1200658760	808007H08M050	5M		
	1200060584	804007E03M050	5M	1200655017	804007P82M200	10M	1200658761	808007H08M100	10M		
	1200062682	804007E03M0501	5.01M	1200010098	804007P03M030W	20M	1200658695	808007I03M010	1M		
	1200658515	804007E03M0501H	5.01M	1200010099	804007P03M050W	3M	1200658696	808007I03M020	2M		
	1200062238	804007E03M100	10M	1200010102	804007P03M200W	5M	1200658697	808007I03M030	3M		
	1200063575	804007E03M1001	10.01M	1200010796	804007P03M500W	20M	1200658698	808007I03M040	4M		
	1200658516	804007E03M1001H	10.01M	1200658096	805007E03M020	50M	1200658699	808007I03M050	5M		
B	1200063576	804007E03M1501	15.01M	1200062929	805007E03M050	2M	1200658700	808007I03M100	10M		
	1200064280	804007E03M200	20M	1200062498	805007E03M100	5M	1200658626	808007P02M010	1M		
	1200063656	804007E03M2001	20.01M	1200658748	805007H09M010	10M	1200651800	808007P02M020	2M		
	1200658235	804007E03M2501	25.01M								
	1200064175	804007E03M4001	40.01M								
	1200658734	804007H09M010	1M								
	1200658735	804007H09M015	1.5M								
	1200658736	804007H09M020	2M								
	1200658737	804007H09M030	3M								
	1200658738	804007H09M040	4M								
A	1200658739	804007H09M050	5M								
	1200658740	804007H09M100	10M								
	1200658602	804007I03M010	1M								
	1200060589	804007I03M020	2M								

ENTER DESCRIPTION EC NO: IPG2014-0972 DRW:NFSCHAFHAUSER 2013/11/26 CHKD:PMERUNKA 2014/06/10 APPR:RSILLER 2014/06/18 REV 2	QUALITY SYMBOLS 	GENERAL TOLERANCES (UNLESS SPECIFIED)		DIMENSION STYLE MM ONLY		SCALE 1:1	DESIGN UNITS METRIC	THIRD ANGLE PROJECTION			
		4 PLACES ± --- ± --- 3 PLACES ± --- ± --- 2 PLACES ± 0.05 ± --- 1 PLACE ± 0.10 ± --- 0 PLACE ± --- ± ---	mm INCH ± --- ± --- ± --- ± --- ± 0.05 ± --- ± 0.10 ± --- ± --- ± ---	DRAWN BY PMERUNKA	DATE 2012/04/24	TITLE CSE M12 XP AC MA RA XM SE UNSH					
		CHECKED BY RSILLER		DATE 2013/01/18							
		APPROVED BY APOHL		DATE 2013/11/18		MATERIAL NO. SEE TABLE		DOCUMENT NO. SD-120065-051		SHEET NO. 3 OF 4	
DRAFT WHERE APPLICABLE MUST REMAIN WITHIN DIMENSIONS				THIS DRAWING CONTAINS INFORMATION THAT IS PROPRIETARY TO MOLEX INCORPORATED AND SHOULD NOT BE USED WITHOUT WRITTEN PERMISSION							

PART NUMBER	NUMERICAL CODE	CABLE LENGTH "L" IN M
1200658628	808007P02M030	3M
1200658629	808007P02M040	4M
1200658258	808007P02M050	5M
1200658259	808007P02M100	10M
1200655109	80C007H45M020	2M
1200659081	804007E03M050Y	5M

ENTER DESCRIPTION EC NO: IPG2014-0972 DRW:NFSCHAFHAUSER 2013/11/26 CHKD:PMERUNKA 2014/06/10 APPR:RSILLER 2014/06/18	DESCRIPTION REV 2	QUALITY SYMBOLS ▽=0 ◻=0	GENERAL TOLERANCES (UNLESS SPECIFIED)		DIMENSION STYLE MM ONLY		SCALE 1:1	DESIGN UNITS METRIC	THIRD ANGLE PROJECTION		
						DRAWN BY PMERUNKA	DATE 2012/04/24	TITLE CSE M12 XP AC MA RA XM SE UNSH			
						CHECKED BY RSILLER	DATE 2013/01/18				
							APPROVED BY APOHL	DATE 2013/11/18	molex DOCUMENT NO. SD-120065-051 SHEET NO. 4 OF 4		
						MATERIAL NO. SEE TABLE					
				DRAFT WHERE APPLICABLE MUST REMAIN WITHIN DIMENSIONS							
					SIZE A3	THIS DRAWING CONTAINS INFORMATION THAT IS PROPRIETARY TO MOLEX INCORPORATED AND SHOULD NOT BE USED WITHOUT WRITTEN PERMISSION					