



Chipsmall Limited consists of a professional team with an average of over 10 year of expertise in the distribution of electronic components. Based in Hongkong, we have already established firm and mutual-benefit business relationships with customers from,Europe,America and south Asia,supplying obsolete and hard-to-find components to meet their specific needs.

With the principle of “Quality Parts,Customers Priority,Honest Operation,and Considerate Service”,our business mainly focus on the distribution of electronic components. Line cards we deal with include Microchip,ALPS,ROHM,Xilinx,Pulse,ON,Everlight and Freescale. Main products comprise IC,Modules,Potentiometer,IC Socket,Relay,Connector.Our parts cover such applications as commercial,industrial, and automotives areas.

We are looking forward to setting up business relationship with you and hope to provide you with the best service and solution. Let us make a better world for our industry!



Contact us

Tel: +86-755-8981 8866 Fax: +86-755-8427 6832

Email & Skype: info@chipsmall.com Web: www.chipsmall.com

Address: A1208, Overseas Decoration Building, #122 Zhenhua RD., Futian, Shenzhen, China





User manual

UM EN CF 500

Electric crimper CF 500

User manual

Electric crimper CF 500

2012-04-10

Designation: UM EN CF 500

Revision: 03

Order No.: —

This user manual is valid for:

Designation	Order No.
CF 500-230V	1208348
CF 500-120V	1208351

Please observe the following notes

User group of this manual

The use of products described in this manual is oriented exclusively to qualified electricians or persons instructed by them, who are familiar with applicable standards and other regulations regarding electrical engineering and, in particular, the relevant safety concepts.

Explanation of symbols used and signal words



This is the safety alert symbol. It is used to alert you to potential personal injury hazards. Obey all safety measures that follow this symbol to avoid possible injury or death.

There are three different categories of personal injury that are indicated with a signal word.

DANGER This indicates a hazardous situation which, if not avoided, will result in death or serious injury.

WARNING This indicates a hazardous situation which, if not avoided, could result in death or serious injury.

CAUTION This indicates a hazardous situation which, if not avoided, could result in minor or moderate injury.



This symbol together with the signal word **NOTE** and the accompanying text alert the reader to a situation which may cause damage or malfunction to the device, hardware/software, or surrounding property.



This symbol and the accompanying text provide the reader with additional information or refer to detailed sources of information.

How to contact us

Internet

Up-to-date information on Phoenix Contact products and our Terms and Conditions can be found on the Internet at:

www.phoenixcontact.com

Make sure you always use the latest documentation.

It can be downloaded at:

www.phoenixcontact.net/catalog

Subsidiaries

If there are any problems that cannot be solved using the documentation, please contact your Phoenix Contact subsidiary.

Subsidiary contact information is available at www.phoenixcontact.com.

Published by

PHOENIX CONTACT GmbH & Co. KG
Flachsmarktstraße 8
32825 Blomberg
GERMANY

Should you have any suggestions or recommendations for improvement of the contents and layout of our manuals, please send your comments to:

tecdoc@phoenixcontact.com

General terms and conditions of use for technical documentation

Phoenix Contact reserves the right to alter, correct, and/or improve the technical documentation and the products described in the technical documentation at its own discretion and without giving prior notice, insofar as this is reasonable for the user. The same applies to any technical changes that serve the purpose of technical progress.

The receipt of technical documentation (in particular user documentation) does not constitute any further duty on the part of Phoenix Contact to furnish information on modifications to products and/or technical documentation. You are responsible to verify the suitability and intended use of the products in your specific application, in particular with regard to observing the applicable standards and regulations. All information made available in the technical data is supplied without any accompanying guarantee, whether expressly mentioned, implied or tacitly assumed.

In general, the provisions of the current standard Terms and Conditions of Phoenix Contact apply exclusively, in particular as concerns any warranty liability.

This manual, including all illustrations contained herein, is copyright protected. Any changes to the contents or the publication of extracts of this document is prohibited.

Phoenix Contact reserves the right to register its own intellectual property rights for the product identifications of Phoenix Contact products that are used here. Registration of such intellectual property rights by third parties is prohibited.

Other product identifications may be afforded legal protection, even where they may not be indicated as such.

Table of contents

1	Basic information	1-1
	1.1 Intended use.....	1-1
	1.2 Workplaces	1-2
	1.3 For your safety.....	1-2
2	Description of the CF 500	2-1
	2.1 Supplied as standard.....	2-1
	2.2 Overview of the operating components	2-1
	2.3 Function of the operating components.....	2-2
	2.4 Scope of use of the CF 500	2-2
3	Starting up the CF 500	3-1
	3.1 Overview	3-1
	3.2 How to proceed	3-1
4	Operation	4-1
	4.1 One-step crimping.....	4-1
	4.2 Two-step crimping.....	4-2
5	Troubleshooting	5-1
	5.1 "Error" LED lights up.....	5-1
	5.2 CF 500 will not switch on	5-2
A	Appendix	A-1
	A 1 Ordering data	A-1
	A 2 Technical data.....	A-3
	A 3 Declaration of conformity.....	A-4

1 Basic information

For safe handling and trouble-free operation of the CF 500, you must be familiar with and observe the safety notes.

1.1 Intended use



WARNING: The CF 500 is intended solely for crimping.

Only crimping dies with suitable cross sections may be used (see "Crimping dies and protective covers" on page A-1).

Under no circumstances should solid metal parts or other similar objects be inserted. This damages the crimping die.

Unauthorized conversions that exceed the scope of modification, and changes to the CF 500 are not permitted for safety reasons.



NOTE: Correct usage includes observing all notes and complying with the predefined operating conditions.



WARNING: The CF 500 may only be used

- as intended and
- in a safe, and fault-free condition.



WARNING: All persons responsible for startup, operation, and maintenance of the CF 500 must be appropriately qualified and adhere strictly to this user manual.

The CF 500 is used for crimping various types of crimp contacts:

- Ferrules
- TWIN ferrules
- Turned contacts
- Slip-on sleeves and flat plugs
- Insulated cable lugs
- Cable lugs
- Tube lugs

Other crimp contacts on request.

Permitted operators

Only authorized and instructed operators may work with the CF 500.

The operator is responsible for all other persons within the workspace.

The owner must make the user manual available to the operator and ensure that the operator has read and understood it.



WARNING: Only use original crimp dies and replacement parts from Phoenix Contact.

1.2 Workplaces



NOTE: During operation and storage, avoid the following:

- Humid or dusty places and
- Locations exposed to high levels of heat, direct sunlight or low temperatures (operating range: 10°C to 40°C).



NOTE: Do not spill liquids on the CF 500.

Do not expose the CF 500 to strong vibrations or shocks.

1.3 For your safety



WARNING: The protective cover is fitted for the safety of the operator. Under no circumstances must it be modified, removed or bypassed by means of alterations.



WARNING: The CF 500 must only be operated with the protective cover attached.

Disconnect the mains plug prior to all work that requires removal of the protective cover (e.g., crimping die adjustment).

Switch off the electric crimper during breaks and when the device is not being used.

For reasons of safety, the CF 500 automatically switches off when the protective cover is removed.



WARNING: Disconnect the mains plug before opening the housing.

2 Description of the CF 500

2.1 Supplied as standard

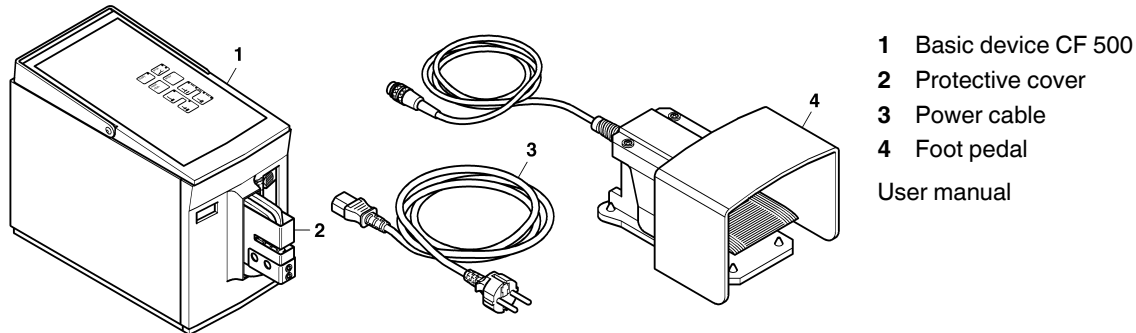

2.2 Overview of the operating components

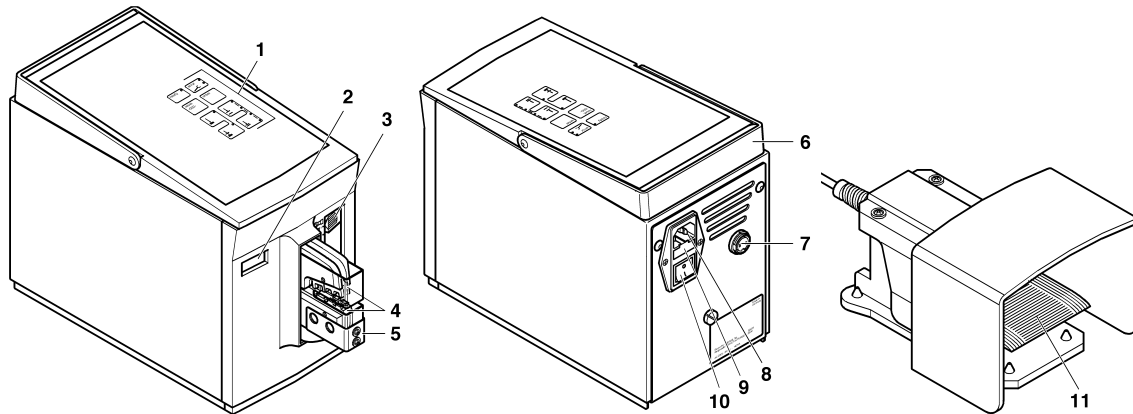

- | | |
|-------------------------|--|
| 1 Control panel | Selection of operating functions and display of device states. |
| 2 Counter | The counter records each complete crimping process. The counter reading is saved for approximately one week when the device is switched off. |
| 3 Adjusting slide | The adjusting slide sets the area in which the crimping die is compressed with full force. If the die meets with resistance outside this area, the crimping pliers are opened immediately. (1 = minimum area, 5 = maximum area.) |
| 4 Crimping die | Positions the crimp contact and crimps this with the wire. |
| 5 Protective cover | The protective cover prevents injury in the crimping die danger zone. The CF 500 can only be operated when the protective cover is fully attached. |
| 6 Carrier handle | The carrier handle is used for transporting the CF 500. |
| 7 Foot pedal connection | Device connection for the foot pedal. |
| 8 Mains connection | Device connection for the power cable. |
| 9 Mains fuses | Micro fuses integrated into the mains connection (2x). |
| 10 Mains switch | The mains switch switches the power supply on (I pressed) or off (0 pressed). The "ready" LED lights up when switched on. |
| 11 Foot pedal | The foot pedal initiates the crimping process. |

2.3 Function of the operating components



"Ready" LED – indicates that the unit is ready for operation.



"Error" LED – indicates that crimping failed or that there is a malfunction.

Press the "enter" button, the LED goes out and you can continue to crimp.



"Reset" button – resets the counter reading to zero.



"Service" LED – indicates that the CF 500 requires servicing. We recommend servicing by Phoenix Contact after 500,000 crimping processes in order to ensure a consistent level of crimping quality.



"Operating mode 1" – switches the CF 500 to operating mode 1 (LED lights up). In operating mode 1, the crimping process takes place in one step.



"Enter" button – clears the "Error" LED.



"Operating mode 2" button – switches the CF 500 to operating mode 2 (LED lights up). In operating mode 2, the crimping process takes place in two steps. In the first step, only the contact is fixed in the die.



Buttons for limiting the opening – the opening of the crimping die can be adjusted by pressing the upper (open) or lower (close) button. The LEDs indicate the opening status:

- 4 LEDs light up: Maximum opening
- No LEDs light up: Minimum opening

Changes are only effective once the next crimping procedure has been carried out.

2.4 Scope of use of the CF 500

The CF 500 electric crimper is used for crimping crimp contacts.

By using different crimping dies, various types of crimp contacts with a wide range of cross sections can be processed.

The CF 500 can be operated in two different operating modes:

- **Operating mode 1:** The crimp contact is crimped when the foot pedal is pressed.
- **Operating mode 2:** The foot pedal is pressed twice. The first press secures the inserted contact in the die. The second time the foot pedal is pressed, the crimp contact is crimped.

The press capacity can be adjusted. This prevents damage to the tools and faulty crimping due to incorrectly inserted contacts.

The opening stroke of the crimping die can be changed by simply pressing a button.

For precise crimping, a moveable locator, which positions the contacts directly under the crimping stamp, can be fitted.

Available crimping dies

Available crimping dies are listed in the "Crimping dies and protective covers" ordering data on page A-1. A protective cover with a suitable insertion slot is assigned to each crimping die.

3 Starting up the CF 500

3.1 Overview

To start up the electric crimper, you must carry out the following steps:

- Set up the CF 500
- Remove the protective cover
- Fit the crimping die
- Attach the protective cover
- Connect and switch on the CF 500
- Center the crimping die
- Adjust the crimping die
- Prepare the unit for operation
- Set the optimum press capacity start
- Set the optimum opening stroke

3.2 How to proceed

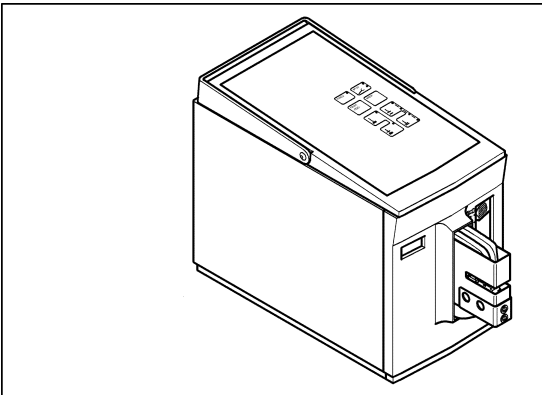

Setting up the CF 500



NOTE: The device must be set up on a level and horizontal surface.



NOTE: During operation and storage, avoid the following:

- Humid or dusty places and
- Locations exposed to high levels of heat, direct sunlight or low temperatures (operating range: 10°C ... 40°C).

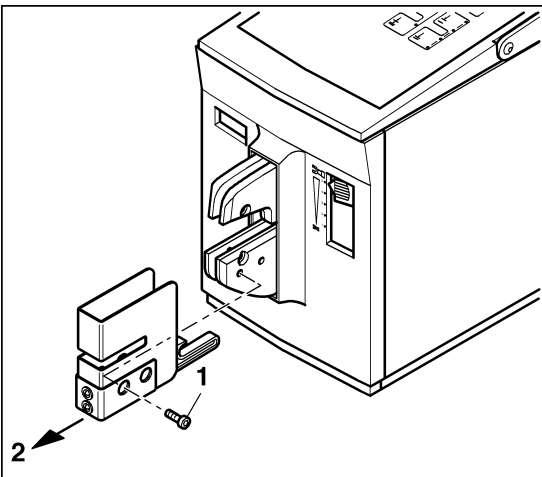

Removing the protective cover



WARNING: Risk of injury

Disconnect the mains plug before removing the protective cover.

- Unscrew the screw (1).
- Remove the protective cover (2).

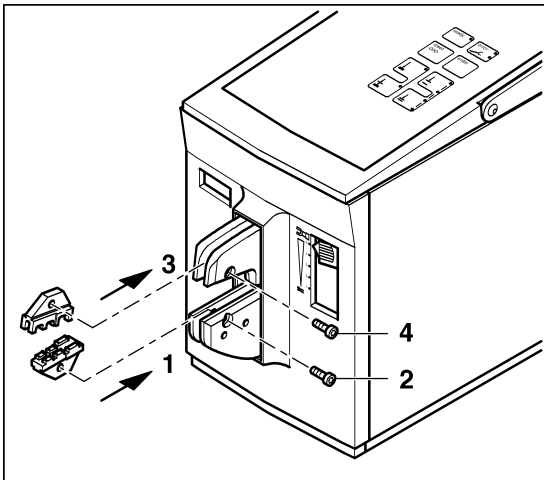

Fitting the crimping die



NOTE: Observe the mounting position:

- Small cross section to the front
- Large cross section to the rear

- Insert the lower crimping die (1).
- **Gently** tighten the screw (2).
- Insert the upper crimping die (3).
- **Gently** tighten the screw (4).

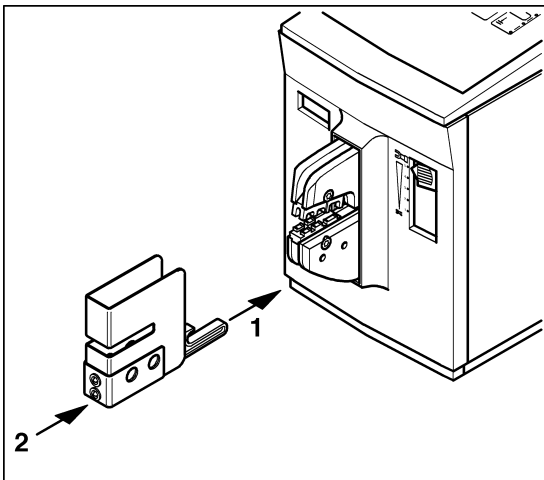

Attaching the protective cover

- Insert the security pin (1) into the lower crimping die and slide the protective cover (2) in until you feel it engage.



WARNING: The CF 500 must only be operated with the protective cover attached.



NOTE: If the protective cover is missing or incorrectly attached, then the CF 500 power supply disconnects.

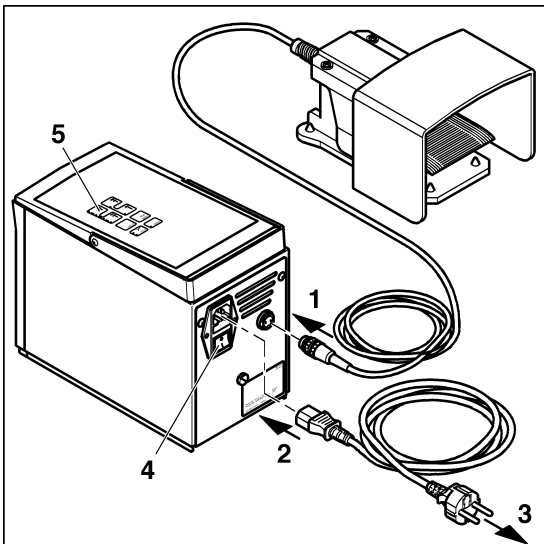

Connecting and switching on the CF 500

- Connect the foot pedal (1) to the foot pedal connection.



NOTE: The CF 500 is available in two versions for 230 V and 120 V. Make sure the mains connection is correct (see rating plate).

- Connect the mains plug (2) to the mains connection and the shock-proof plug (3) to the socket.
- Switch on the CF 500 with the mains switch (4) (press I). The "ready" LED lights up (5).

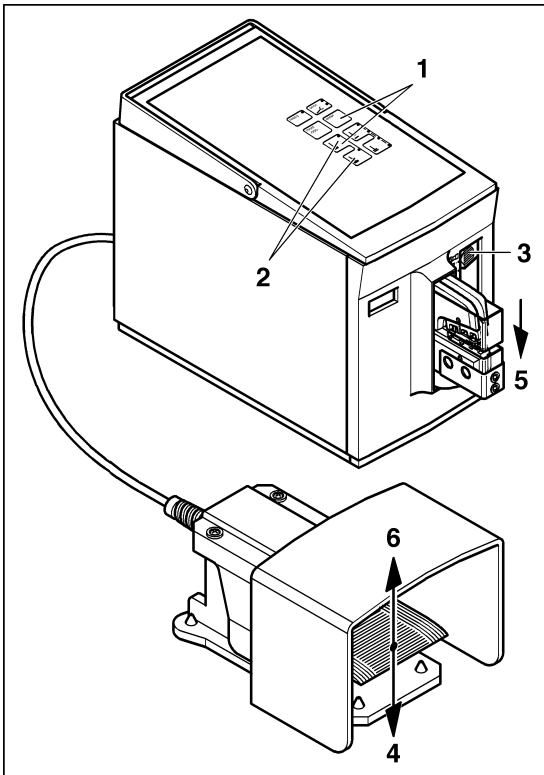

Centering the crimping die



NOTE: The crimping die bore holes have some play for the mounting screws. Therefore you need to center and adjust the crimping die.

- Press the "operating mode 1" and "enter" buttons simultaneously (1).
- The LEDs for the "operating mode 1 + 2" buttons flash (2).
- Push the adjusting slide (3) to position 1.



NOTE: Only release the foot pedal once the crimping die is closed. Otherwise it opens automatically, adjustment mode is terminated, and the "error" LED lights up.

- Press and hold down the foot pedal (4).
- The crimping die (5) closes slowly, until it meets with resistance and centers itself.
- Release the foot pedal (6).

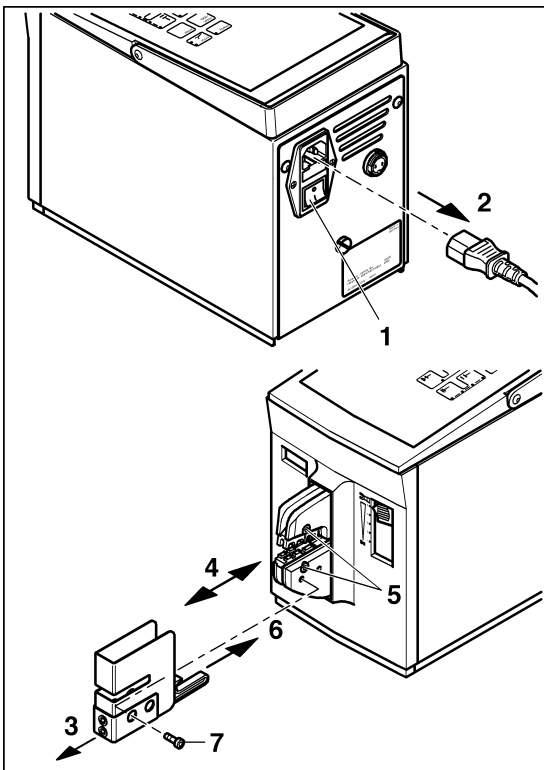

Adjusting the crimping die



WARNING: Risk of injury

Disconnect the mains plug before removing the protective cover.

- Switch off the CF 500 with the mains switch (1) (press 0).
- Disconnect the mains plug (2).
- Unscrew the screw (7).
- Remove the protective cover (3).
- Check the centering of the crimping die, adjust if necessary (4).
- Tighten the screws (5).
- Attach the protective cover (6) and tighten the screw (7).

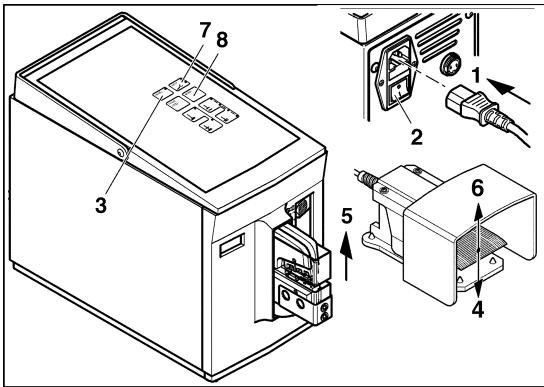

Preparing the unit for operation

- Plug in the mains plug (1).
- Switch on the mains switch (2) (press I).
The "ready" LED lights up (3).
- Press the foot pedal (4).
- The crimping die (5) opens automatically; release the foot pedal (6).
The "error" LED lights up (7).
- Press the "enter" button (8).
The CF 500 is ready to operate.



NOTE: The device is set to operating mode 2. Check the operating mode before each use.

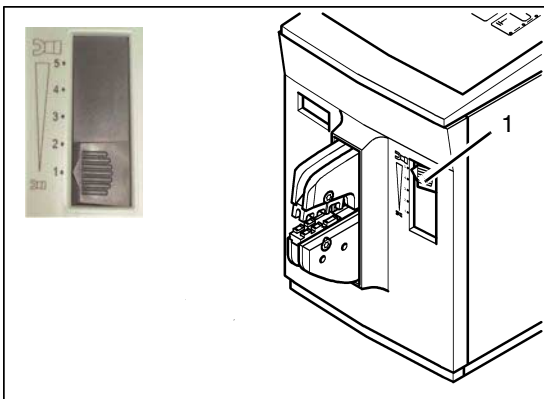

Setting the optimum press capacity start (1 ... 5)

- Push the adjusting slide (1) into position 1.
- Use the button to set "operating mode 1".
- Press the foot pedal.
One crimp process is performed without an inserted crimp contact. If the "error" LED lights up, check the position of the crimping die (see page 3-3).
- Insert the wire and the crimp contact.



NOTE: Ensure the cross section is correct.

- Press the foot pedal.
- If the "error" LED lights up, move the adjusting slide up one position.
- Press the "enter" button.
- Repeat the process until the "error" LED no longer lights up.
- To compensate for any material tolerances, push the adjusting slide up one more position.

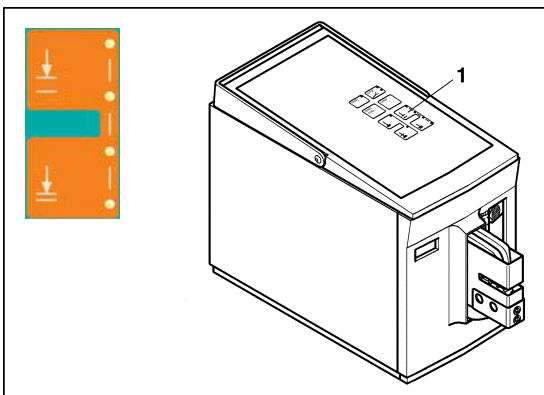

Setting the optimum opening stroke

- Press the upper button until all four LEDs light up.
The maximum opening stroke is set.
- Carry out the crimping process.



NOTE: Changes to settings only take effect after the next crimping process.

- If the opening stroke is too large, press the lower button so that only three LEDs light up.
- Carry out the crimping process.
- Repeat the process until the optimum opening stroke is set.

4 Operation

4.1 One-step crimping

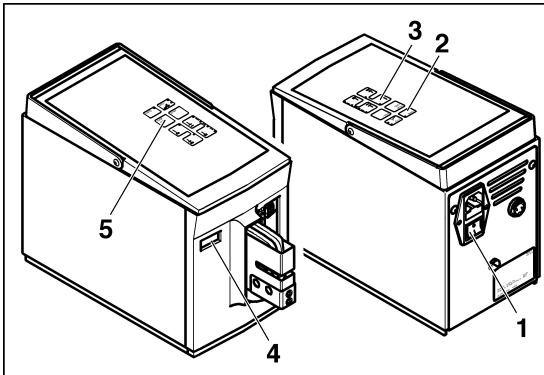

Setting operating mode 1

- Switch on the CF 500 with the mains switch (1) (press I).
- The "ready" LED lights up (2).
- Press the "operating mode 1" button (3).
- If necessary, read the counter (4) and press the "reset" button to reset it to zero (5).

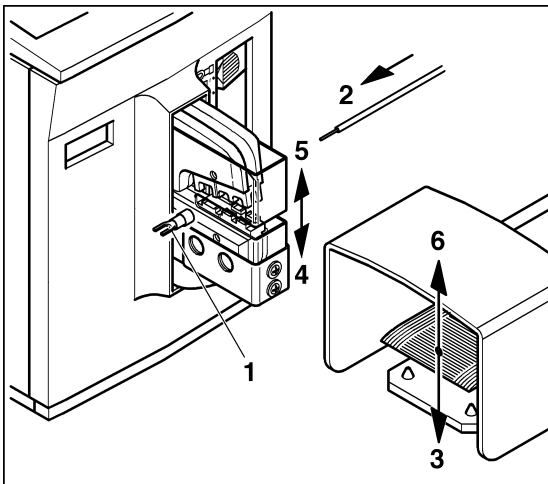

Crimping the crimp contact

- Center the crimp contact (1) on the lower crimping die.
- Insert the wire (2) into the crimp contact.



NOTE: Ensure the cross section is correct.

- Press the foot pedal (3) until the crimping die is completely closed (4).
- The crimping die (5) opens automatically; release the foot pedal (6).
- Remove the crimp contact with crimped wire (7).



NOTE: If there was a fault with the crimping, the "error" LED lights up (see page 5-1).

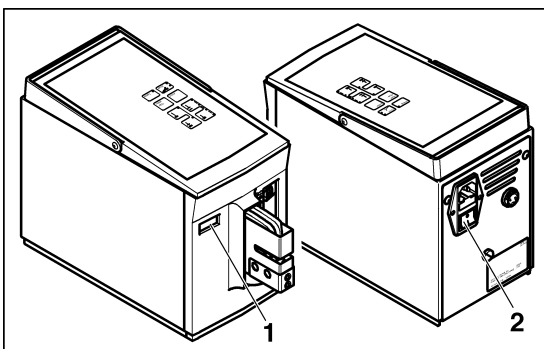

Shutting down

- If necessary, read the counter (1).
- Switch off the CF 500 with the mains switch (2) (press 0).

4.2 Two-step crimping

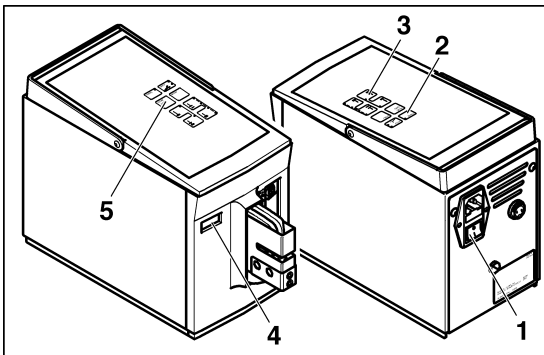

Setting operating mode 2

- Switch on the CF 500 with the mains switch (1) (press I).
- The "ready" LED lights up (2).
- Press the "operating mode 2" button (3).
- If necessary, read the counter (4) and press the "reset" button to reset it to zero (5).

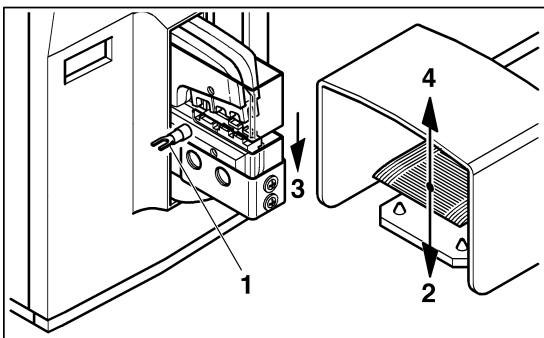

Clamping the crimp contact



NOTE: Ensure the cross section is correct.

- Center the crimp contact (1) on the lower crimping die.
- Press the foot pedal (2) until the crimp contact is clamped (3).
- Release the foot pedal (4).

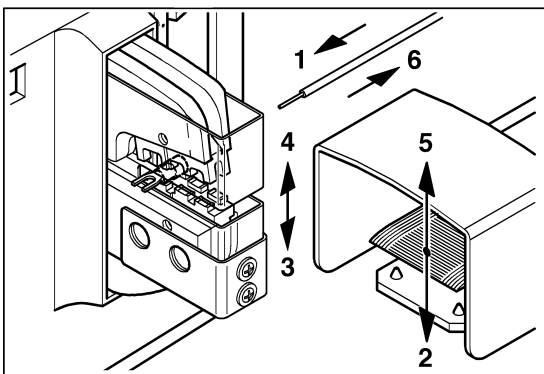

Crimping the crimp contact

- Insert the wire (1) into the crimp contact.
- Press the foot pedal (2) until the crimping die is completely closed (3).
- The crimping die (4) opens automatically; release the foot pedal (5).
- Remove the crimp contact with crimped wire (6).



NOTE: If there was a fault with the crimping, the "error" LED lights up (see page 5-1).

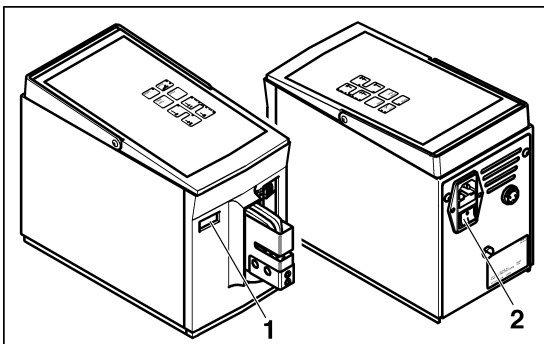

Shutting down

- If necessary, read the counter (1).
- Switch off the CF 500 with the mains switch (2) (press 0).

5 Troubleshooting

5.1 "Error" LED lights up



This malfunction can be caused by:

- Foot pedal released too soon
- Incorrect cross section selected
- Incorrectly set press capacity start (1 ... 5)
- Crimping die incorrectly adjusted



Foot pedal released too soon

If the foot pedal is released too soon, the crimping die immediately opens up as far as its initial position.

- Press the "enter" button.
The "error" LED goes out.
- Repeat the crimping process.



Incorrect cross section selected

If a crimp contact that is too large or another unsuitable object is inserted, the crimping process is interrupted due to overload and the crimping die immediately opens as far as its initial position.

- Press the "enter" button.
The "error" LED goes out.
- Repeat the crimping process with the correct cross section.

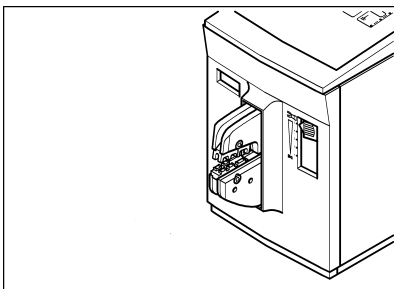

Incorrectly set press capacity start (1 ... 5)

The inserted contact is too large for the selected area.

- Push the adjusting slide up one position.
- Press the "enter" button.
The "error" LED goes out.
- Repeat the crimping process until the press capacity is optimally set.

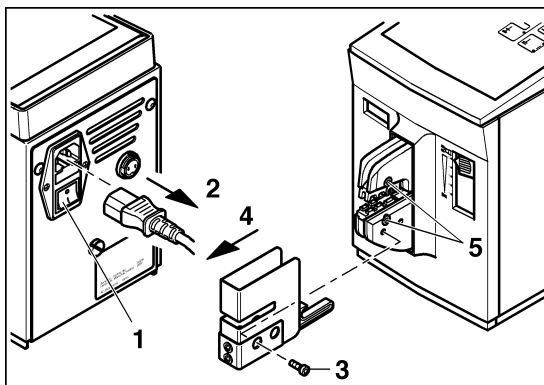

Crimping die incorrectly adjusted



WARNING: Risk of injury

Disconnect the mains plug before removing the protective cover.

- Switch off the CF 500 with the mains switch (1) (press 0).
- Disconnect the mains plug (2).
- Unscrew the screw (3).
- Remove the protective cover (4).
- Loosen the screws (5).
- Carry out the startup steps (see Section 3).

5.2 CF 500 will not switch on

The CF 500 will not switch on. The "ready" LED does not light up. This malfunction can be caused by:

- No mains connection
- Mains fuse blown



No mains connection

- Check whether the mains plug is connected to the CF 500 mains connection and the shock-proof plug is connected to the mains socket.
- Make sure that the power supply at the mains socket is OK.

Mains fuse blown



WARNING: Risk of injury

Switch off the CF 500 via the mains switch and disconnect the mains plug.

- Switch off the CF 500 with the mains switch (1) (press 0).
- Disconnect the mains plug (2).
- Pull out the fuse holder (3).
- Check the mains fuses (4).
- Replace the blown mains fuse (for Order No. see ordering data on page A-1).
- Insert the fuse holder..



NOTE: The fuse holder must snap into place.

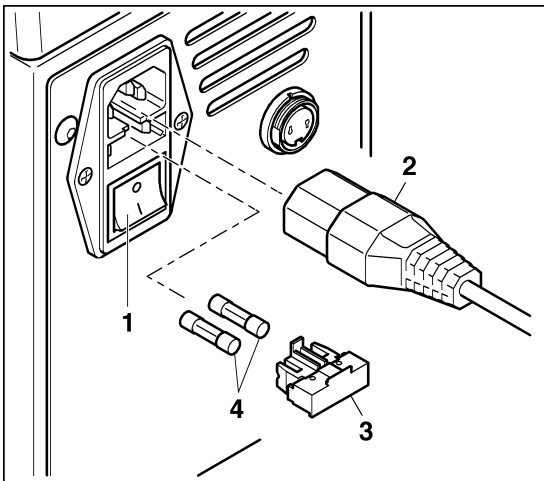







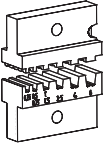

A Appendix

A 1 Ordering data

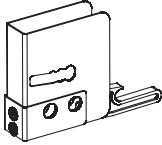
Electric crimper

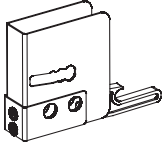
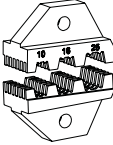
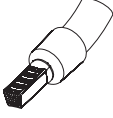
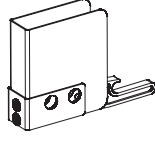
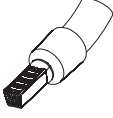
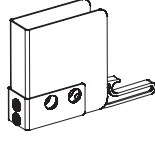
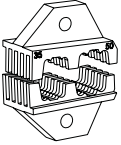
Description	Type	Order No.
Electric crimper 230 V	CF 500-230V	1208348
Electric crimper 120 V	CF 500-120V	1208351
Mains fuse for CF 500-230V	FUSE SB 1.25 A	1208801
Mains fuse for CF 500-120V	FUSE SB 2.5 A	1209062

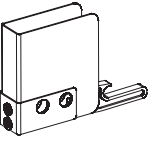
Crimping dies and protective covers

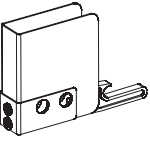
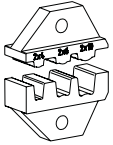
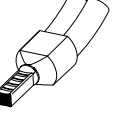
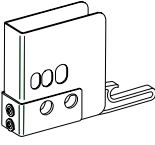
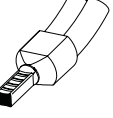
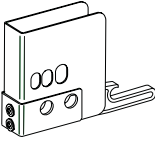
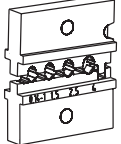
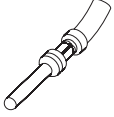
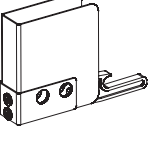
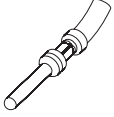
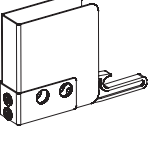
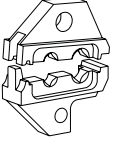
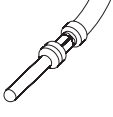
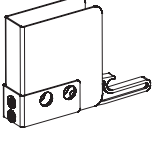
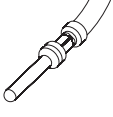
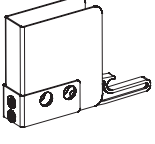
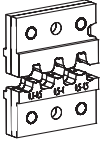
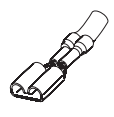
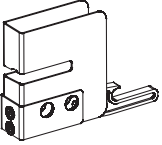
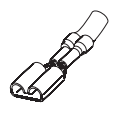
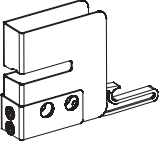
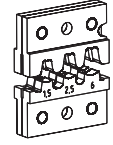
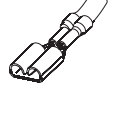
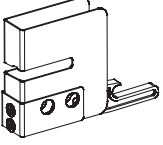
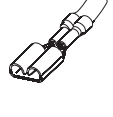
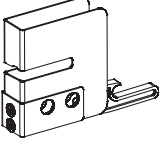
<p>CF 500/DIE AI 6 Order No. 1212238</p>    <p>For ferrules (A... and AI...), 0.25 ... 6 mm²</p>	<p>CF 500/COV AI 6 Order No. 1212254</p>  	<p>CF 500/DIE AI 25 Order No. 1212239</p>    <p>For ferrules (A... and AI...), 10, 16, and 25 mm²</p>	<p>CF 500/COV¹ Order No. 1212250</p>  
<p>CF 500/DIE AI 50 Order No. 1212261</p>    <p>For ferrules (A... and AI...), 35 and 50 mm²</p>	<p>CF 500/COV¹ Order No. 1212250</p>  	<p>CF 500/DIE AI-TWIN 10 Order No. 1212262</p>    <p>For TWIN ferrules (AI-TWIN), 2 x 4, 2 x 6, and 2 x 10 mm²</p>	<p>CF 500/COV AI-TWIN Order No. 1212266</p>  
<p>CF 500/DIE TC 4 Order No. 1212237</p>    <p>For turned contacts (CK...), 0.14 ... 4 mm²</p>	<p>CF 500/COV¹ Order No. 1212250</p>  	<p>CF 500/DIE TC 10 Order No. 1212260</p>    <p>For turned contacts (CK...), 6 ... 10 mm²</p>	<p>CF 500/COV¹ Order No. 1212250</p>  
<p>CF 500/DIE SC 1,5 Order No. 1212241</p>    <p>For slip-on sleeves and flat plugs (SCF..., SCM...), 0.1 ... 1.5 mm²</p>	<p>CF 500/COV SC Order No. 1212251</p>  	<p>CF 500/DIE SC 6 Order No. 1212242</p>    <p>For slip-on sleeves and flat plugs (SCF..., SCM...), 0.5 ... 6 mm²</p>	<p>CF 500/COV SC Order No. 1212251</p>  

CF 500...

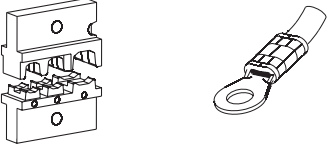
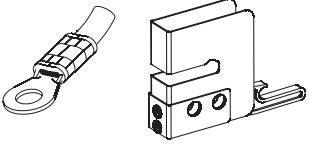
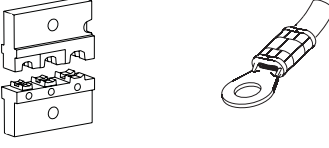
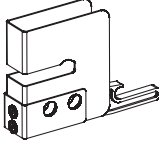
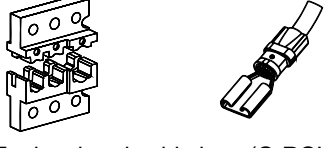
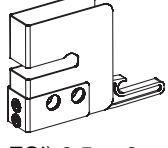
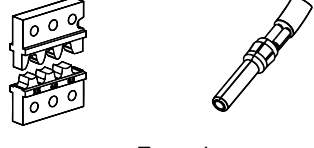
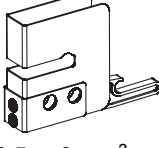
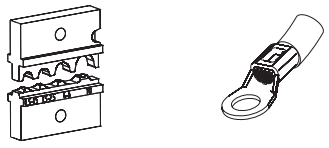
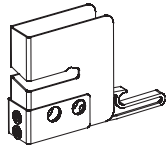
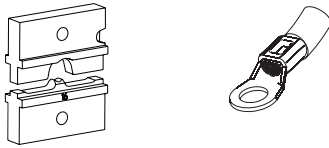
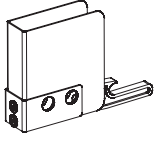
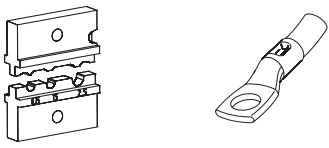
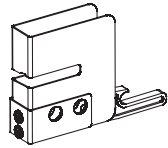
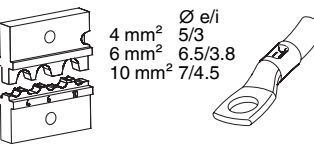
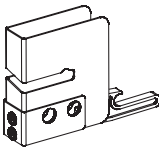
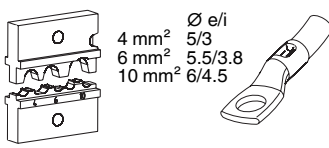
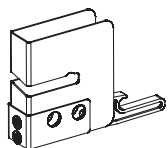
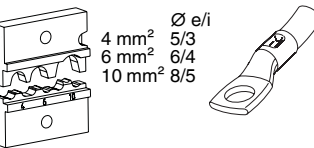
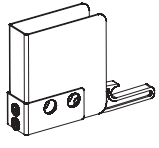
<p>CF 500/DIE RCI 6 Order No. 1212240</p>  <p>For insulated cable lugs (RCI, FCI,...), 0.5 ... 6 mm²</p>	<p>CF 500/COV RCI Order No. 1212255</p> 	<p>CF 500/DIE RCI 1,5 Order No. 1212263</p>  <p>For insulated cable lugs (RCI, FCI,...), 0.14 ... 1.0 mm²</p>	<p>CF 500/COV RCI Order No. 1212255</p> 
<p>CF 500/DIE RCI 6-1 Order No. 1212691</p>  <p>For insulated cable lugs (C-RCI, C-FCI) 0.5 ... 6 mm², asymmetrical crimp shape, also suitable for insulated slip-on sleeves with metallic insulation support</p>	<p>CF 500/COV RCI Order No. 1212255</p> 	<p>CF 500/DIE SR 6-2 Order No. 1212692</p>  <p>For solar contacts 2.5 ... 6 mm²</p>	<p>CF 500/COV RCI Order No. 1212255</p> 
<p>CF 500/DIE RC 10 Order No. 1212244</p>  <p>For cable lugs according to DIN 46234 (RC, FC,...), 0.5 ... 10 mm²</p>	<p>CF 500/COV RC 10 Order No. 1212252</p> 	<p>CF 500/DIE RC 16 Order No. 1212257</p>  <p>For cable lugs according to DIN 46234, (RC, FC,...), 16 mm²</p>	<p>CF 500/COV¹ Order No. 1212250</p> 
<p>CF 500/DIE RCT 2,5 Order No. 1212243</p>  <p>For tube lugs, 0.34 ... 2.5 mm²</p>	<p>CF 500/COV RCT 2,5 Order No. 1212253</p> 	<p>CF 500/DIE RCT 10-1 Order No. 1212245²⁾</p>  <p>4 mm² 5/3 6 mm² 6.5/3.8 10 mm² 7/4.5</p> <p>For tube lugs (standard), 4 ... 10 mm²</p>	<p>CF 500/COV RC 10 Order No. 1212252</p> 
<p>CF 500/DIE RCT 10-2 Order No. 1212246²⁾</p>  <p>4 mm² 5/3 6 mm² 5.5/3.8 10 mm² 6/4.5</p> <p>For tube lugs according to DIN 46235, 4 ... 10 mm²</p>	<p>CF 500/COV RC 10 Order No. 1212252</p> 	<p>CF 500/DIE RCT 10-3 Order No. 1212256²⁾</p>  <p>4 mm² 5/3 6 mm² 6/4 10 mm² 8/5</p> <p>For tube lugs (special), 4 ... 10 mm²</p>	<p>CF 500/COV¹ Order No. 1212250</p> 

1) CF 500 - Protective cover without recess

2) Ø e/i (external/internal diameter, in millimeters), in relation to the cross section of the cable lug

Locator for slip-on sleeves and flat plugs

For precise crimping, a moveable locator, which precisely positions the contacts under the crimping stamp, can be fitted.

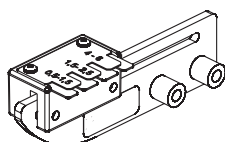

Type	Order No.	Crimp contacts	Die	Protective cover
CF 500/LOC SCF 6,3/6	1212247	Slip-on sleeves (SCF...) up to 6.3 mm wide	CF 500/DIE SC 6	CF 500/COV SC

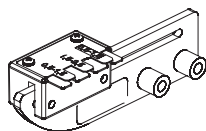

CF 500/LOC SCF 4,8/2,5	1212248	Slip-on sleeves (SCF...) up to 4.8 mm wide	CF 500/DIE SC 1,5 CF 500/DIE SC 6	CF 500/COV SC
------------------------	---------	--	--------------------------------------	---------------

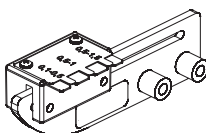

CF 500/LOC SCF 2,8/1,5	1212249	Slip-on sleeves (SCF...) up to 2.8 mm wide and 5 mm long	CF 500/DIE SC 1,5 CF 500/DIE SC 6	CF 500/COV SC
------------------------	---------	--	--------------------------------------	---------------

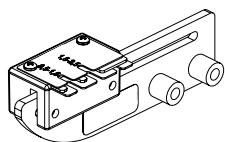

CF 500/LOC SCM 6,3/2,5	1212264	Flat plug (SCM...), 0.5 ... 2.5 mm ²	CF 500/DIE SC 1,5 CF 500/DIE SC 6	CF 500/COV SC
------------------------	---------	---	--------------------------------------	---------------

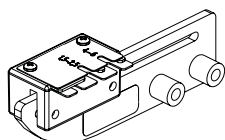

CF 500/LOC SCM 6,3/6	1212265	Flat plug (SCM...), 1.5 ... 6 mm ²	CF 500/DIE SC 1,5 CF 500/DIE SC 6	CF 500/COV SC
----------------------	---------	---	--------------------------------------	---------------

A 2 Technical data

Technical data

Mains connection

CF 500-230V

230 V/50 Hz

CF 500-120V

120 V/60 Hz

Power consumption

160 VA

Maximum press capacity

10 kN

Press time

< 1 s

Counter

6-digit LCD, can be reset

Dimensions (W x H x D)

140 mm x 220 mm x 320 mm





Weight of basic device

10 kg

Weight of foot pedal

1.2 kg

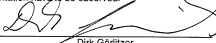
A 3 Declaration of conformity

<div style="text-align: center;">  <p>10-04110.01.00</p> </div> <p style="text-align: center;">EG-Konformitätserklärung EC-Declaration of Conformity</p> <p>Hersteller / Manufacturer: PHOENIX CONTACT GMBH & CO. KG Anschrift / Address: Flachsmarktstraße 8, D-32825 Blomberg, Germany</p> <p>Produktbezeichnung / Product description: CF 500-230V <small>(Artikelbezeichnung, / Article description, Artikel-Nr. / Article no.)</small> 1208348</p> <p>Das vorstehend bezeichnete Produkt stimmt mit den wesentlichen Anforderungen der nachfolgenden Richtlinie(n) und deren Änderungsrichtlinien überein / The above mentioned product is in line with the essential requirements of the below directive(s) and their modification directive(s):</p> <table style="width: 100%; border-collapse: collapse;"> <tr> <td style="width: 15%;">2004/108/EC</td> <td>EMV-Richtlinie (Elektromagnetische Verträglichkeit) Electromagnetic Compatibility Directive (EMC)</td> </tr> <tr> <td>2006/42/EC</td> <td>Maschinenrichtlinie Machinery Directive</td> </tr> <tr> <td>2006/95/EC</td> <td>Niederspannungs-Richtlinie (NSR) Low Voltage Directive (LVD)</td> </tr> </table> <p>Für die Beurteilung der Übereinstimmung wurden folgende einschlägige Normen herangezogen: For evaluation of the conformity following relevant standards were consulted:</p> <table style="width: 100%; border-collapse: collapse;"> <tr> <td>EN ISO 12100-1:2003</td> <td>EN ISO 12100-2:2003</td> <td>EN ISO 13857:2008</td> </tr> <tr> <td>EN 349:1993 + A1</td> <td>EN 60204-1:2006</td> <td>EN 61000-6-2:2005</td> </tr> <tr> <td>EN 61000-6-3:2007</td> <td></td> <td></td> </tr> </table> <p>Weitere Informationen (z. B. Dokumente, Prüfberichte, Einschränkungen, etc.) zur Konformitätsbewertung: Additional information (for example documents, test reports, restrictions etc.) of the conformity assessment:</p> <p>Zertifikate einer benannten Stelle / Certificates by a notified body:</p> <p>Anschrift / Address: _____ Referenz / Reference: _____ Anschrift / Address: _____ Referenz / Reference: _____</p> <p>Die letzten beiden Ziffern des Jahres in dem die CE-Kennzeichnung angebracht wurde: The last two figures of the year in which the CE marking was applied: <u>10</u> <small>(nur eintragen, bei der Niederspannungsrichtlinie / only to be entered on the low voltage directive)</small></p> <p><input checked="" type="checkbox"/> Diese Erklärung gilt auch für die im Anhang aufgelisteten Produkte. (wenn angekreuzt) This declaration also applies for the products listed in the annex. (if marked with a cross)</p> <p>Diese Erklärung bescheinigt die Übereinstimmung mit den wesentlichen Anforderungen der genannten Richtlinie(n), enthält jedoch keine Zusicherung von Eigenschaften. Die Sicherheits- und Einbauhinweise der mitgelieferten Produktdokumentation sind zu beachten. This declaration certifies the conformity with the essential requirements of the indicated directive(s), it does not, however, covenant any characteristics. The instructions for safety and installation of the enclosed product documentation have to be observed.</p> <p>Blomberg, 2010-03-22</p> <div style="display: flex; justify-content: space-around;"> <div style="text-align: center;">  Sandra Klocke Business Unit Industrial Connection Technology Head of Development Marking System & Service <small>Ansprechpartner / contact person</small> </div> <div style="text-align: center;">  Dirk Göritzer Business Unit Industrial Connection Technology Vice President, Head of the Business Unit <small>Zeichnungsberechtigter / authorized signatory</small> </div> </div> <p style="font-size: small;">FS A-7-0037 / -06 Formblätterstadium: 2008-11-10 Formblättersteller: Corporate Technology 10-04110.01.00.doc Date of form establishment: Form establisher: Blatt / Page 1 von / of 2</p>	2004/108/EC	EMV-Richtlinie (Elektromagnetische Verträglichkeit) Electromagnetic Compatibility Directive (EMC)	2006/42/EC	Maschinenrichtlinie Machinery Directive	2006/95/EC	Niederspannungs-Richtlinie (NSR) Low Voltage Directive (LVD)	EN ISO 12100-1:2003	EN ISO 12100-2:2003	EN ISO 13857:2008	EN 349:1993 + A1	EN 60204-1:2006	EN 61000-6-2:2005	EN 61000-6-3:2007			<div style="text-align: center;">  <p>10-04110.01.00</p> </div> <p style="text-align: center;">Anhang zur EG-Konformitätserklärung Annex on EC Declaration of Conformity vom / dated 22.03.2010</p> <p>Produktbezeichnung / Product description: CF 500-230V <small>(Artikelbezeichnung, / Article description, Artikel-Nr. / Article no.)</small> 1208348</p> <p>Die Konformität mit den wesentlichen Anforderungen der Richtlinie(n) wird auch für folgende Produkte bescheinigt: The conformity with the essential requirements of the directive(s) is also certified by the declaration for following products:</p> <table style="width: 100%; border-collapse: collapse;"> <thead> <tr> <th style="width: 50%; text-align: left;">Artikel-Nr. / Article no.</th> <th style="width: 50%; text-align: left;">Artikelbezeichnung / Article description</th> </tr> </thead> <tbody> <tr> <td style="text-align: center;">1208351</td> <td>CF 500-120V</td> </tr> </tbody> </table> <p style="font-size: small;">10-04110.01.00.doc Blatt / Page 2 von / of 2</p>	Artikel-Nr. / Article no.	Artikelbezeichnung / Article description	1208351	CF 500-120V
2004/108/EC	EMV-Richtlinie (Elektromagnetische Verträglichkeit) Electromagnetic Compatibility Directive (EMC)																			
2006/42/EC	Maschinenrichtlinie Machinery Directive																			
2006/95/EC	Niederspannungs-Richtlinie (NSR) Low Voltage Directive (LVD)																			
EN ISO 12100-1:2003	EN ISO 12100-2:2003	EN ISO 13857:2008																		
EN 349:1993 + A1	EN 60204-1:2006	EN 61000-6-2:2005																		
EN 61000-6-3:2007																				
Artikel-Nr. / Article no.	Artikelbezeichnung / Article description																			
1208351	CF 500-120V																			

PHOENIX CONTACT GmbH & Co. KG, Flachsmarktstraße 8, 32825 Blomberg, Germany

CF 500-230V

CF 500-120V

The above-mentioned products are in conformity with the most important requirements of the following directives and their amending directives.

2004/108/EC EMC Directive (electromagnetic compatibility)

2006/42/EC Machinery Directive

2006/95/EC Low-Voltage Directive (LVD)

The following pertinent standards were consulted for evaluating the conformity:

EN ISO 12100-1:2003 EN ISO 12100-2:2003 EN ISO 13857:2008

EN349:1993 + A1 EN 60204-1:2006 EN 61000-6-2:2005

EN 61000-6-3:2007