



Chipsmall Limited consists of a professional team with an average of over 10 year of expertise in the distribution of electronic components. Based in Hongkong, we have already established firm and mutual-benefit business relationships with customers from,Europe,America and south Asia,supplying obsolete and hard-to-find components to meet their specific needs.

With the principle of “Quality Parts,Customers Priority,Honest Operation,and Considerate Service”,our business mainly focus on the distribution of electronic components. Line cards we deal with include Microchip,ALPS,ROHM,Xilinx,Pulse,ON,Everlight and Freescale. Main products comprise IC,Modules,Potentiometer,IC Socket,Relay,Connector.Our parts cover such applications as commercial,industrial, and automotives areas.

We are looking forward to setting up business relationship with you and hope to provide you with the best service and solution. Let us make a better world for our industry!



## Contact us

Tel: +86-755-8981 8866 Fax: +86-755-8427 6832

Email & Skype: info@chipsmall.com Web: www.chipsmall.com

Address: A1208, Overseas Decoration Building, #122 Zhenhua RD., Futian, Shenzhen, China



# CUSTOMER DRAWING

©2011 CTP-COIL  
ALL DIMENSIONS IN mm

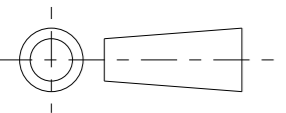

GENERAL VIEW



SCALE 1:1

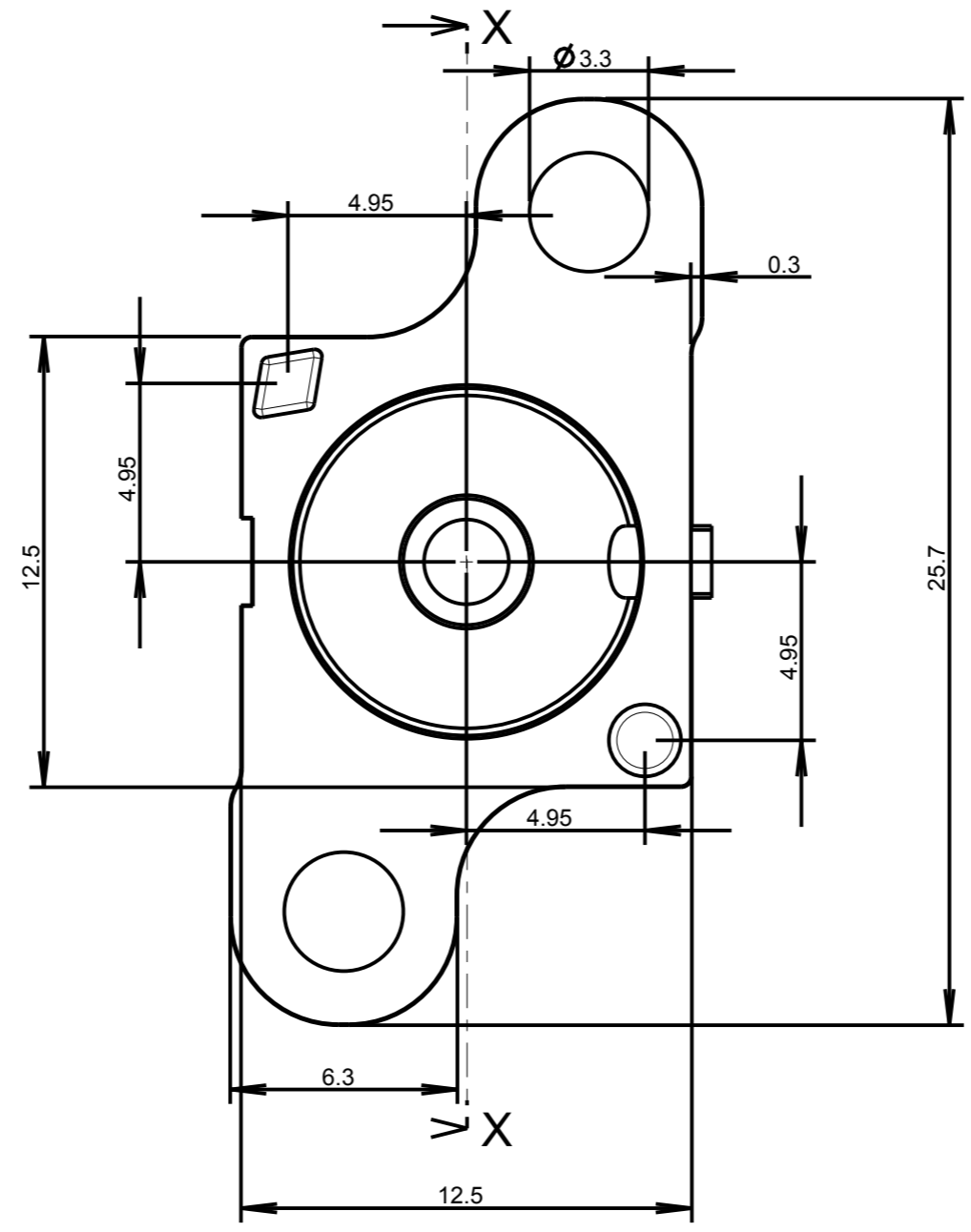
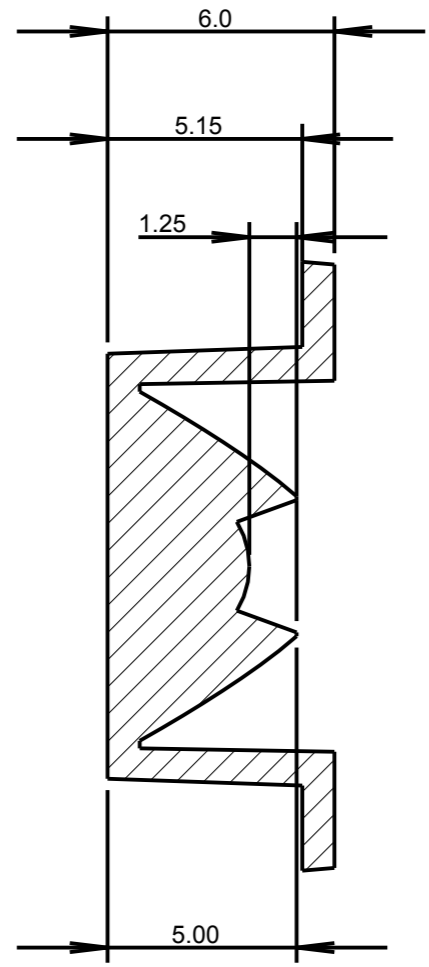

SECTION X-X

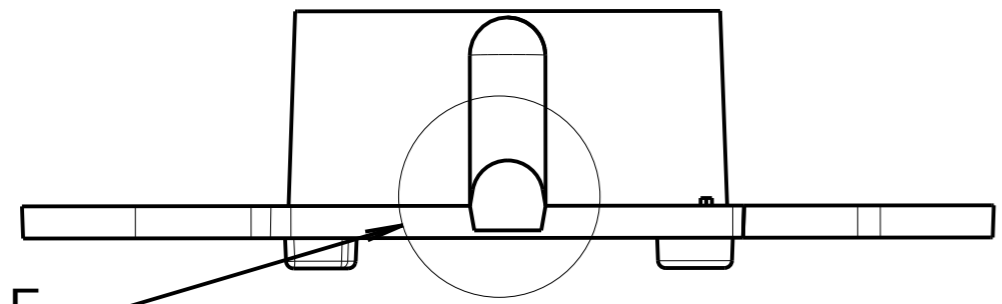

SEE DETAIL E

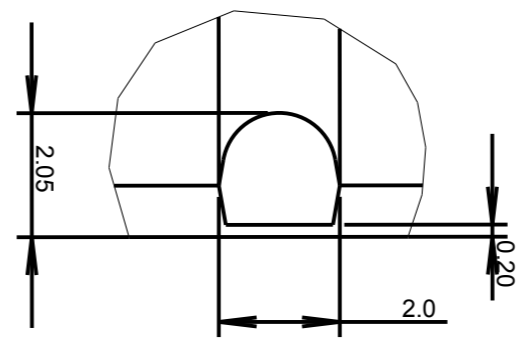

DETAIL E  
SCALE 8:1

- NOTES:
1. MATERIAL - UV STABILISED CLEAR POLYCARBONATE
  2. INCLUSIONS SPECIFIED TO BS ISO 10110.

ISS.	DATE	E.C.N.	DESCRIPTION
1	12-Nov-10		FIRST ISSUE
2	23-Mar-11	03/11/1293	ADD RECESS DIMENSION & GENERAL INFO
3	17-Nov-11	11/11/1314	CHANGE 2.0MM PEGS HEIGHT TO 0.8mm



CARCLO TECHNICAL PLASTICS (SLOUGH)  
103 BUCKINGHAM AVE, SLOUGH  
SL1 4PF, ENGLAND  
TEL: +44 1753 575011 FAX: +44 1753 811359  
email: design@carclo-optics.com

GENERAL TOLERANCES (UNLESS STATED)

LINEAR	ANGULAR
X +/- 0.25	X +/- 1°
X.X +/- 0.1	X.X +/- 0.5°
X.XX +/- 0.05	X.XX +/- 0.1°

CUSTOMER  
CARCLO

TITLE  
10mm IP66 WIDE FROSTED  
- with Locations Pins & Flange

DRAWN BB DATE 12-Nov-10

CHK'D MH DATE 29-Nov-11

APP'D PW DATE 29-Nov-11

SCALE 5:1 CARCLO PART No. 12085

SIZE A3 CARCLO DRG. No. 60655 SHEET 2 OF 3

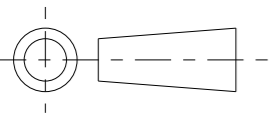

©2011 CTP-COIL  
ALL DIMENSIONS IN mm

## PCB GLUE PAD AND ALIGNMENT HOLE LAYOUT DIMENSIONS

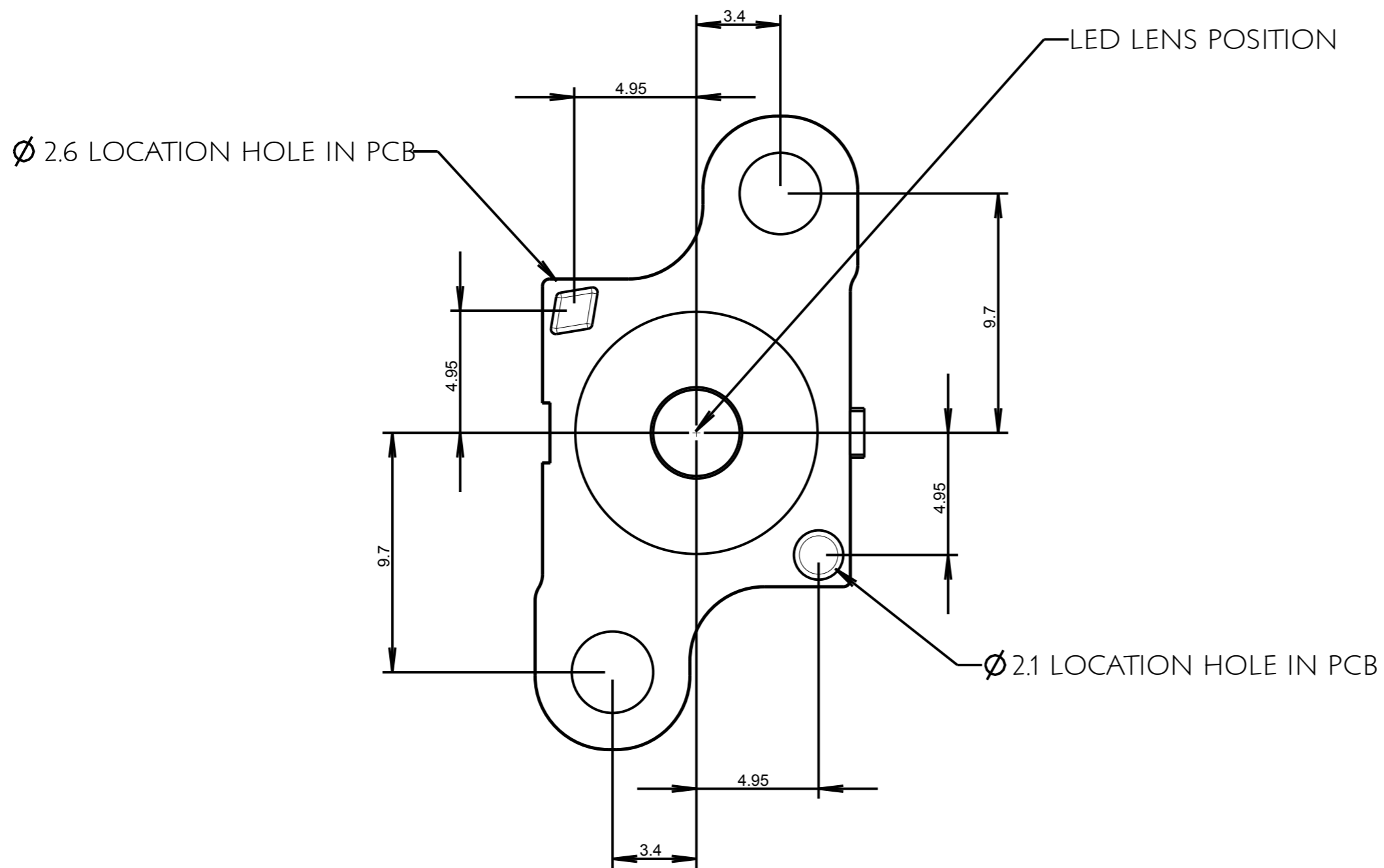

ISS.	DATE	E.C.N.	DESCRIPTION
1	12-Nov-10		FIRST ISSUE
2	23-Mar-11	03/11/1293	ADD RECESS DIMENSION & GENRAL INFO
3	17-Nov-11	11/11/1314	CHANGE 2.0MM PEGS HEIGHT TO 0.8mm



CARCLO TECHNICAL PLASTICS (SLOUGH)  
103 BUCKINGHAM AVE, SLOUGH  
SL1 4PF, ENGLAND  
TEL: +44 1753 575011 FAX: +44 1753 811359  
email: design@carclo-optics.com

GENERAL TOLERANCES (UNLESS STATED)

LINEAR	ANGULAR
X +/- 0.25	X +/- 1°
X.X +/- 0.1	X.X +/- 0.5°
X.XX +/- 0.05	X.XX +/- 0.1°

CUSTOMER

CARCLO

TITLE

10mm IP66 WIDE FROSTED  
- with Locations Pins & Flange

DRAWN BB DATE 12-Nov-10

CHK'D MH DATE 29-Nov-11

APP'D PW DATE 29-Nov-11

SCALE 5:1 CARCLO PART No. 12085

SIZE A3 CARCLO DRG. No. 60655 SHEET 3 OF 3