

Chipsmall Limited consists of a professional team with an average of over 10 year of expertise in the distribution of electronic components. Based in Hongkong, we have already established firm and mutual-benefit business relationships with customers from,Europe,America and south Asia,supplying obsolete and hard-to-find components to meet their specific needs.

With the principle of “Quality Parts,Customers Priority,Honest Operation,and Considerate Service”,our business mainly focus on the distribution of electronic components. Line cards we deal with include Microchip,ALPS,ROHM,Xilinx,Pulse,ON,Everlight and Freescale. Main products comprise IC,Modules,Potentiometer,IC Socket,Relay,Connector.Our parts cover such applications as commercial,industrial, and automotives areas.

We are looking forward to setting up business relationship with you and hope to provide you with the best service and solution. Let us make a better world for our industry!



Contact us

Tel: +86-755-8981 8866 Fax: +86-755-8427 6832

Email & Skype: info@chipsmall.com Web: www.chipsmall.com

Address: A1208, Overseas Decoration Building, #122 Zhenhua RD., Futian, Shenzhen, China

B26 3 000 N 2 **

SERIES
B26= FORM A
POLES
2= 2 POLE & 3= 3 POLE
CURVED BASE DIAMETER
000= FLAT
MATERIAL AND HOUSING COLOUR
N= PA6 BLACK, W= PA6 BLACK V0, G= PA6 GRAY

SCREW AND GASKET
2 = NBR FLAT GASKET & SCREWS
4 = SILICON FLAT GASKET & SCREWS
G = NO GASKET, WITH SCREWS
9 = NO FIXING SCREW AND GASKET WITH SPECIAL TERMINAL

ADDITIONAL CODES
SA= UL AGENCY APPROVAL

PART NO	MPM NO	DESCRIPTION	TERMINAL BEND ANGLE
1210120071	B262000N2	TYPE A 2P BLACK, NBR FLAT GASKET & SCREWS	30
1210120073	B262000N4	TYPE A 2P BLACK, SILICON FLAT GASKET & SCREWS	30
1210120076	B263000N2	TYPE A 3P BLACK, NBR FLAT GASKET & SCREWS	45
1210120078	B263000N4	TYPE A 3P BLACK, SILICON FLAT GASKET & SCREWS	45
1210120080	B263000W2	TYPE A 3P BLACK V0, NBR FLAT GASKET & SCREWS	45
1210120150	B262000W2	TYPE A 2P BLACK V0, NBR FLAT GASKET & SCREWS	30
1210120151	B263000G2	TYPE A 3P GRAY, NBR FLAT GASKET & SCREWS	45
1210120163	B262000NG	TYPE A 2P BLACK, SCREWS, NO GASKET	30
1210120174	B262000W2SA	TYPE A 2P BLACK UL 94-V0, NBR FLAT GASKET & SCREWS	30
1210120175	B263000W2SA	TYPE A 3P BLACK UL 94-V0, NBR FLAT GASKET & SCREWS	45
1210120197	B263000W9SA	TYPE A 3P BLACK UL94-V0, NO GASKET, NO FIXING SCREW, SPECIAL TERMINAL	45

- NOTES
- PLEASE SEE TABLE FOR CURRENTLY CONFIGURED PART NUMBERS. FOR SPECIFIC PART NUMBERS PLEASE CONTACT SALES OR CONSULT THE INTELLIGENT PART NUMBERS IN THE TABLE ATTACHED.
 - FOR PACKAGING SEE PACKAGING SPEC PK-121012-B26
 - PRODUCT SPEC: SEE PS-121201-001
 - TERMINALS BENT AFTER INSERTION, SEE TABLE FOR BEND ANGLE

LAST INSPECTION NUMBER 4

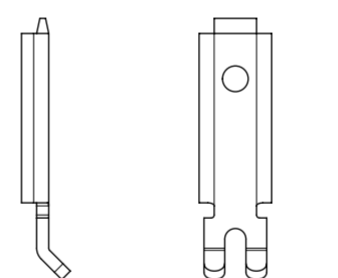
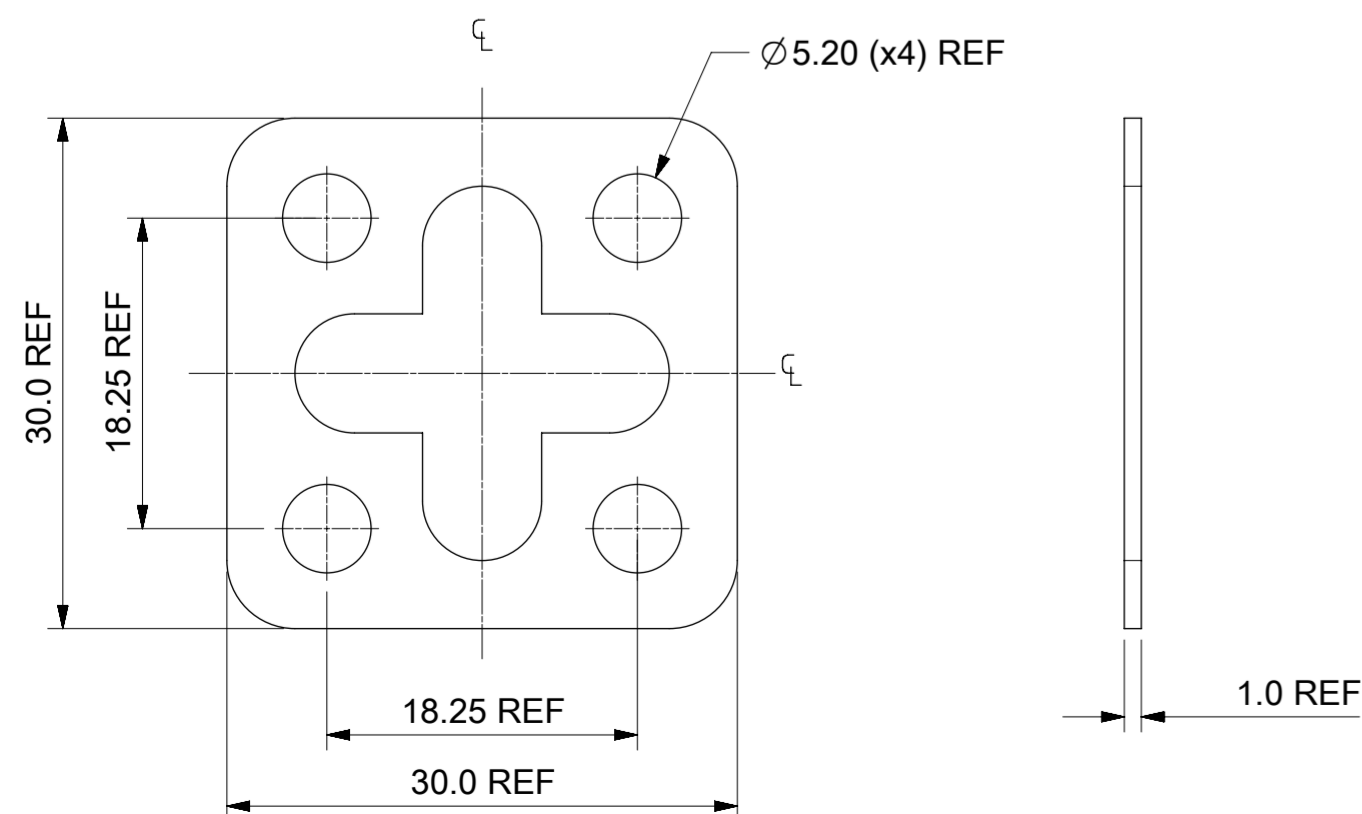

SPECIAL TERMINAL
1211200021

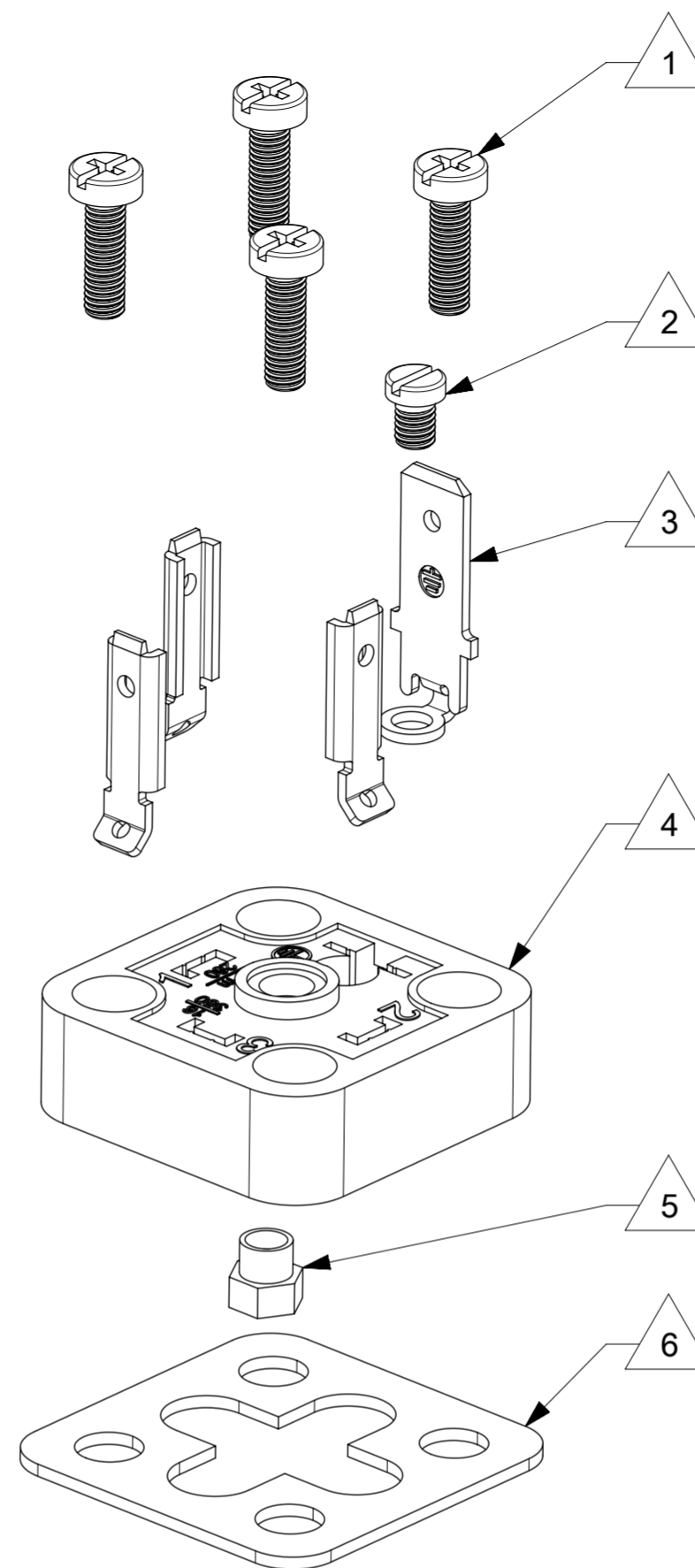
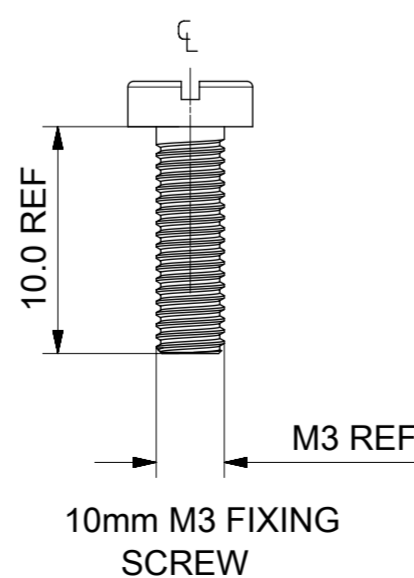
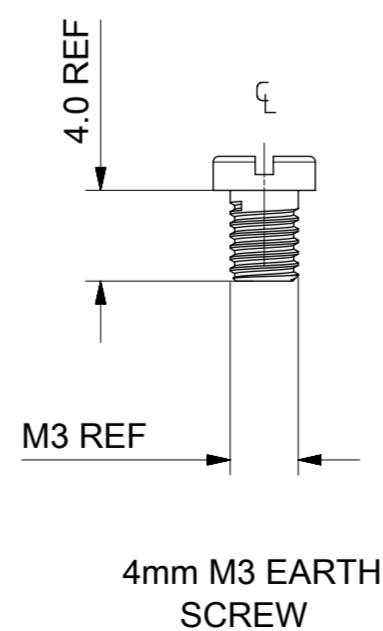

ITEM	DESCRIPTION
1	FIXING SCREW
2	EARTH SCREWS
3	TERMINALS
4	HOUSING
5	INSERT
6	GASKET

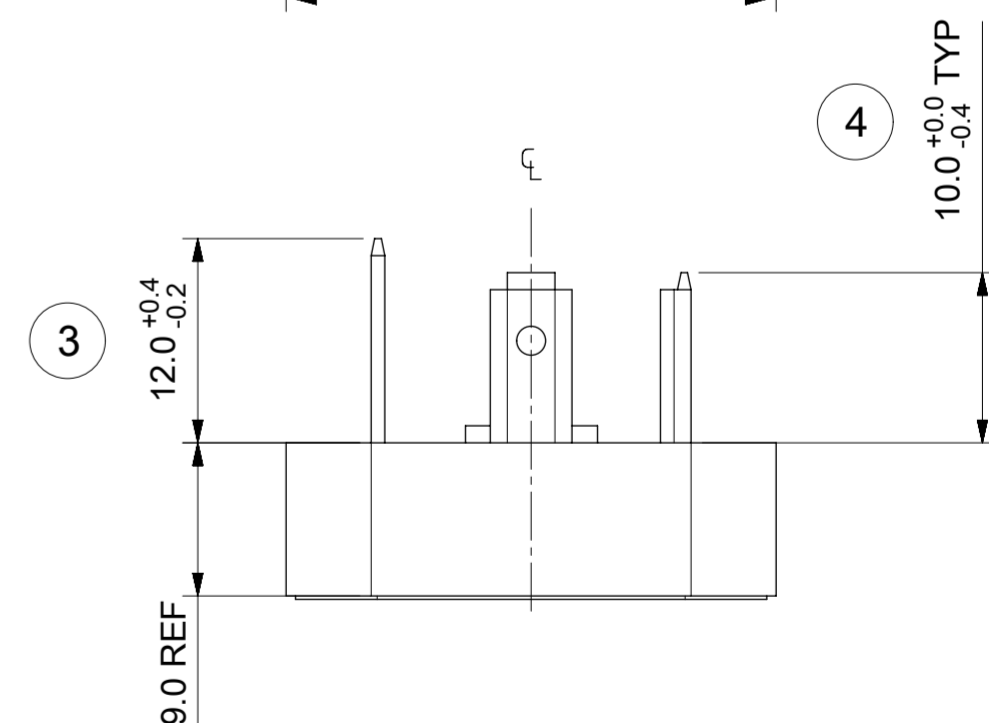
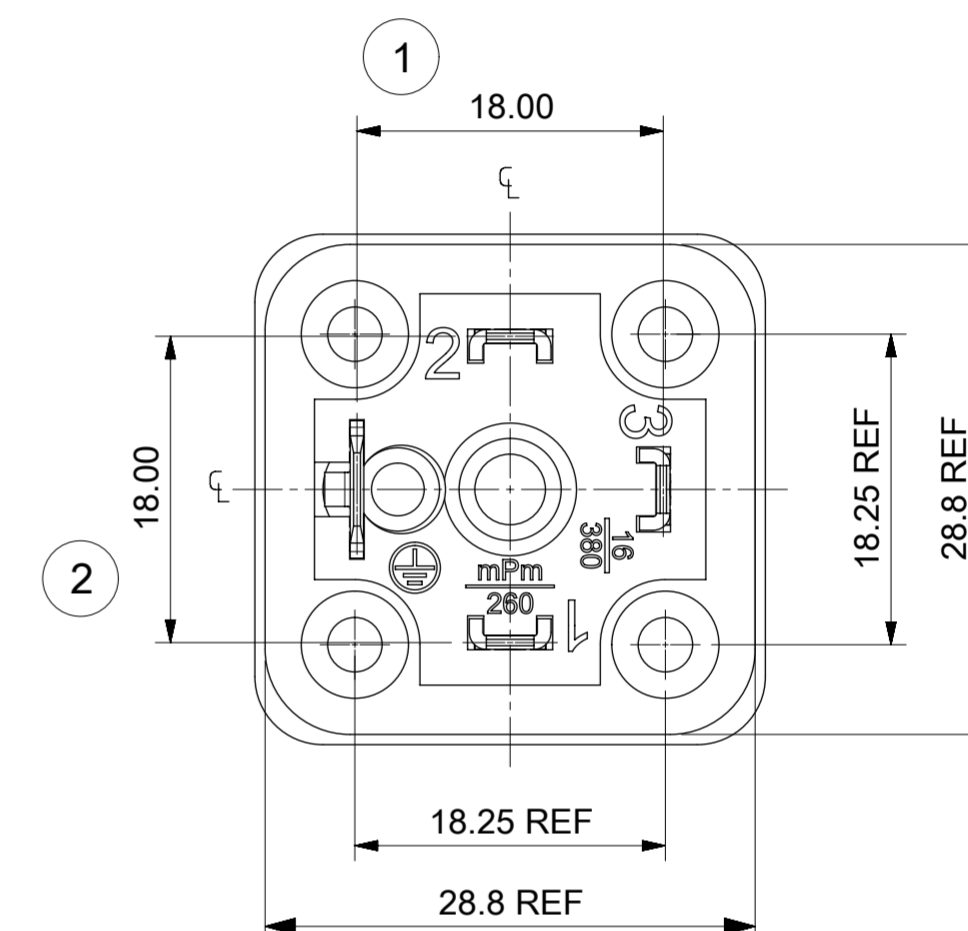
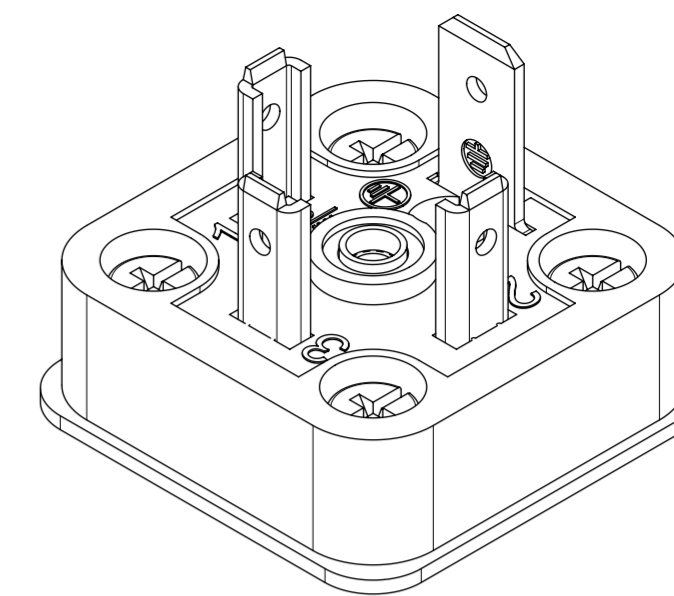

QUALITY SYMBOLS	THIS DRAWING CONTAINS INFORMATION THAT IS PROPRIETARY TO MOLEX ELECTRONIC TECHNOLOGIES, LLC AND SHOULD NOT BE USED WITHOUT WRITTEN PERMISSION		GENERAL TOLERANCES (UNLESS SPECIFIED)		DIMENSION UNITS	SCALE	molex B26 SERIES BASE		
▽ = 0	2016/09/14	2016/12/20	ANGULAR TOL ± 2.0 °		MM				
▽ = 0	DRWN: TCLEARY	CHKD: BCAFFREY	4 PLACES ±	2013/09/17	DRWN BY	DATE	SERIES MATERIAL NUMBER CUSTOMER		
▽ = 0	EC NO: 108524	APPR: DMAHER	3 PLACES ±	2016/12/20	CHK'D BY	DATE	121012 SEE TABLE GENERAL MARKET		
▽ = 0	REV: D		2 PLACES ± 0.1		APPR BY	DATE	DOCUMENT NUMBER DOC TYP DOC PART SHEET NUMBER		
▽ = 0			1 PLACE ± 0.2		STGRIFFIN	2013/10/23	SD-121012-002 PSD 000 1 OF 1		
▽ = 0			0 PLACES ±		DRAFT WHERE APPLICABLE MUST REMAIN WITHIN DIMENSIONS				
▽ = 0					DRAWING SIZE	THIRD ANGLE PROJECTION			
					A2				