



Chipsmall Limited consists of a professional team with an average of over 10 year of expertise in the distribution of electronic components. Based in Hongkong, we have already established firm and mutual-benefit business relationships with customers from,Europe,America and south Asia,supplying obsolete and hard-to-find components to meet their specific needs.

With the principle of "Quality Parts,Customers Priority,Honest Operation,and Considerate Service",our business mainly focus on the distribution of electronic components. Line cards we deal with include Microchip,ALPS,ROHM,Xilinx,Pulse,ON,Everlight and Freescale. Main products comprise IC,Modules,Potentiometer,IC Socket,Relay,Connector.Our parts cover such applications as commercial,industrial, and automotives areas.

We are looking forward to setting up business relationship with you and hope to provide you with the best service and solution. Let us make a better world for our industry!



Contact us

Tel: +86-755-8981 8866 Fax: +86-755-8427 6832

Email & Skype: info@chipsmall.com Web: www.chipsmall.com

Address: A1208, Overseas Decoration Building, #122 Zhenhua RD., Futian, Shenzhen, China



Screwdriver - SZS 0,6X3,5 VDE - 1212602

Please be informed that the data shown in this PDF Document is generated from our Online Catalog. Please find the complete data in the user's documentation. Our General Terms of Use for Downloads are valid (<http://phoenixcontact.com/download>)



Screwdriver, slot-headed, VDE insulated, size: 0.6 x 3.5 x 100 mm, 2-component grip, with non-slip grip

Why buy this product

- The tools feature ergonomic two-component safety handles
- Large contact surface of blades inside screw head
- Individually tested safety screwdrivers according to DIN EN 60900 (VDE 0682-201)
- For working on or in the vicinity of live parts up to 1000 V AC or 1500 V DC

Key Commercial Data

Packing unit	10 STK
GTIN	 4 046356 590761
GTIN	4046356590761

Technical data

Dimensions

Length (b)	181 mm
Width (a)	26 mm
Blade thickness	0.6 mm
Blade width	3.5 mm
Blade height	100 mm
Wrench size	0 mm

General

Type	Bladed
	straight
Material	alloyed tool steel
Test standard	DIN/ISO 2380-1 IEC 60900:2004
Weight	35 g

Standards and Regulations

Test standard	DIN/ISO 2380-1 IEC 60900:2004
---------------	-------------------------------

Screwdriver - SZS 0,6X3,5 VDE - 1212602

Drawings

Pictogram



Dimensional drawing

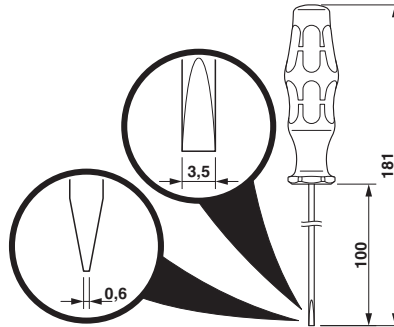

Approvals

Approvals

Approvals

VDE Zeichengenehmigung / EAC

Ex Approvals

Approval details

VDE Zeichengenehmigung		http://www2.vde.com/de/Institut/Online-Service/VDE-gepruefteProdukte/Seiten/Online-Suche.aspx	086858
------------------------	--	---	--------

EAC			RU x- DE.xx08.B.02974
-----	--	--	--------------------------

Phoenix Contact 2018 © - all rights reserved
<http://www.phoenixcontact.com>

PHOENIX CONTACT GmbH & Co. KG
Flachmarktstr. 8
32825 Blomberg
Germany
Tel. +49 5235 300
Fax +49 5235 3 41200
<http://www.phoenixcontact.com>