



Chipsmall Limited consists of a professional team with an average of over 10 year of expertise in the distribution of electronic components. Based in Hongkong, we have already established firm and mutual-benefit business relationships with customers from,Europe,America and south Asia,supplying obsolete and hard-to-find components to meet their specific needs.

With the principle of “Quality Parts,Customers Priority,Honest Operation,and Considerate Service”,our business mainly focus on the distribution of electronic components. Line cards we deal with include Microchip,ALPS,ROHM,Xilinx,Pulse,ON,Everlight and Freescale. Main products comprise IC,Modules,Potentiometer,IC Socket,Relay,Connector.Our parts cover such applications as commercial,industrial, and automotives areas.

We are looking forward to setting up business relationship with you and hope to provide you with the best service and solution. Let us make a better world for our industry!



## Contact us

Tel: +86-755-8981 8866 Fax: +86-755-8427 6832

Email & Skype: info@chipsmall.com Web: www.chipsmall.com

Address: A1208, Overseas Decoration Building, #122 Zhenhua RD., Futian, Shenzhen, China



# Adapters for Snaps Used as Electrical Connectors For Grounding ESD Protective Workstations

## Adapters for Various Brands of Wristbands and Ground Cords

### Three Adapters to Adapt ESD Systems.com Ground Cords to Other Wristbands

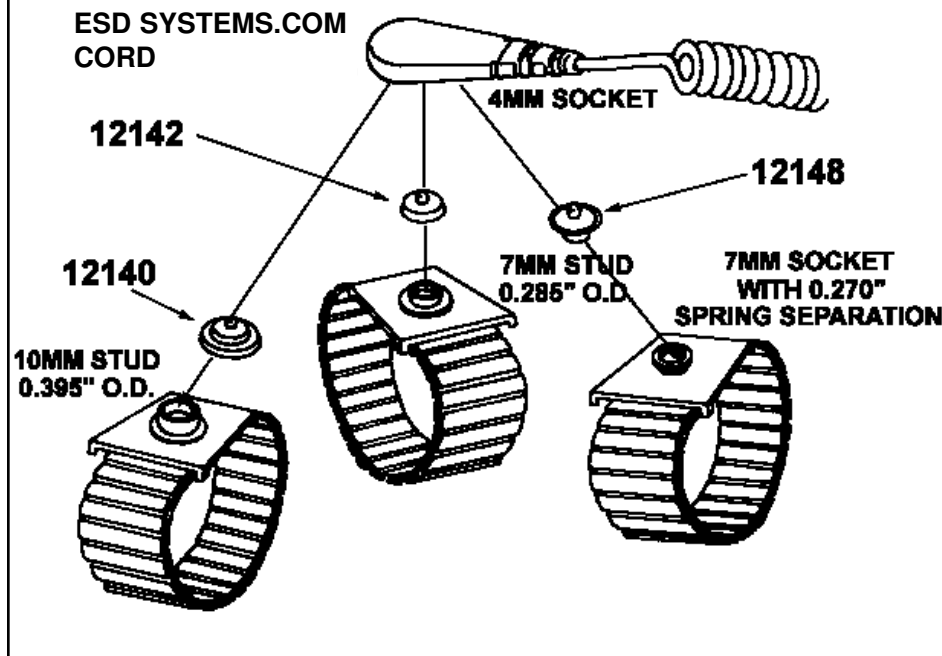

There are three connector systems commonly used for ESD protective grounding. These are the 4mm (1/8"), 7mm (1/4") and 10mm (3/8") snap. These are available in both male (stud) and female (socket) snaps.

No standard exists for connectors for ESD protective grounding. The most commonly used snaps may be found in various products and in various configurations depending upon the original manufacturer.

ESD Systems.com has adapters available to adapt ESD Systems.com products to other manufacturer's products. These adapters are illustrated in this Tech Brief.

Because of the possible confusion in measurement of studs and sockets we suggest that you try a sample of these adapters before purchase. ESD Systems.com will supply samples upon request.

- 12140** Adapts a 3/8" (10mm) stud to a 1/8" (4mm) socket
- 12142** Adapts a 1/4" (7mm) stud to a 1/8" (4mm) socket
- 12144** Adapts a 3/8" (10mm) socket to a 1/8" (4mm) stud
- 12146** Adapts a 1/4" (7mm) socket to a 1/8" (4mm) stud
- 12148** Adapts a 1/4" (7mm) socket to a 1/8" (4mm) socket

### Two Adapters to Adapt ESD Systems.com Wristbands to Other Ground Cords

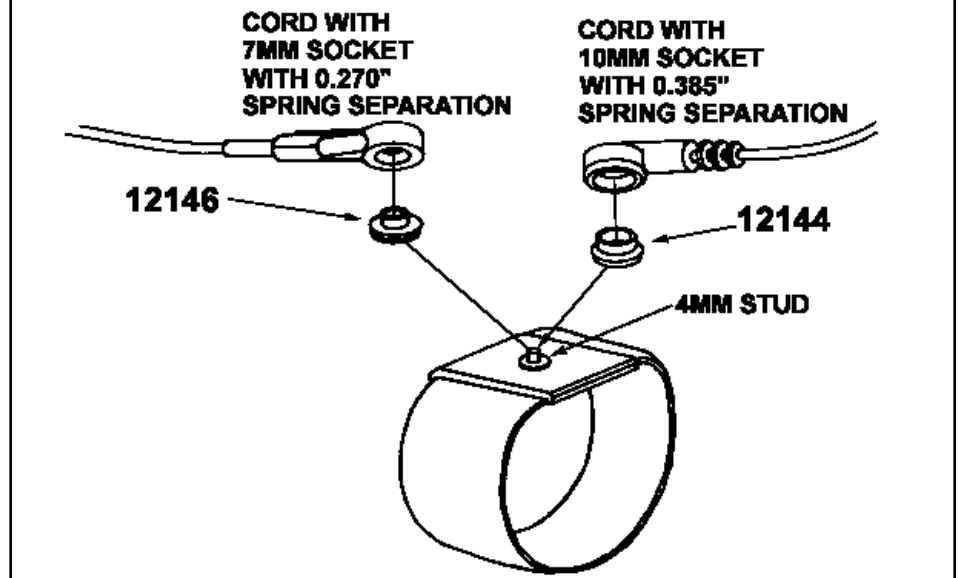

# Adapters for Workstation Mat Grounding

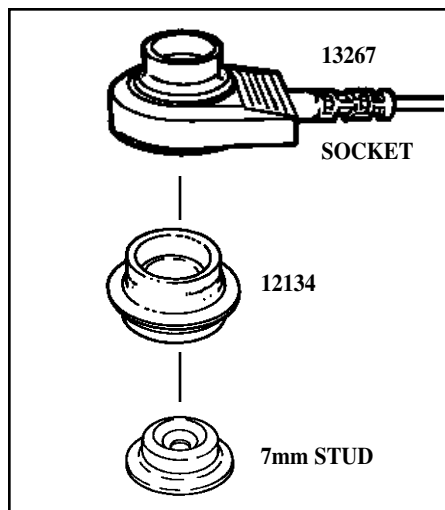
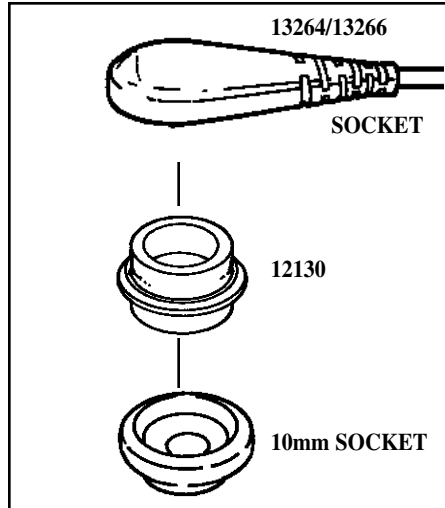
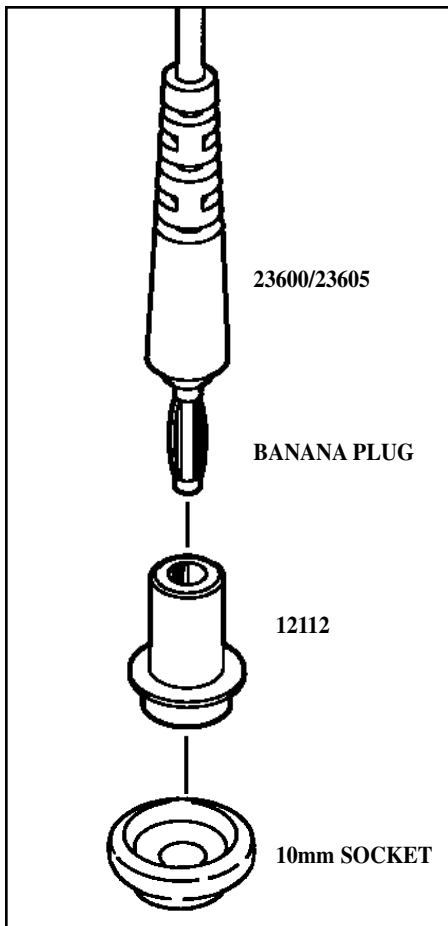
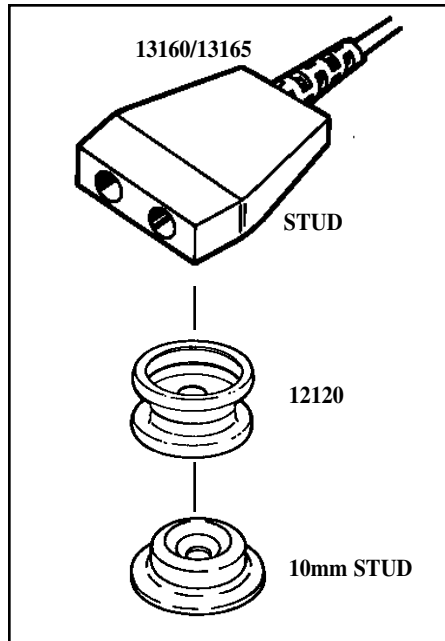
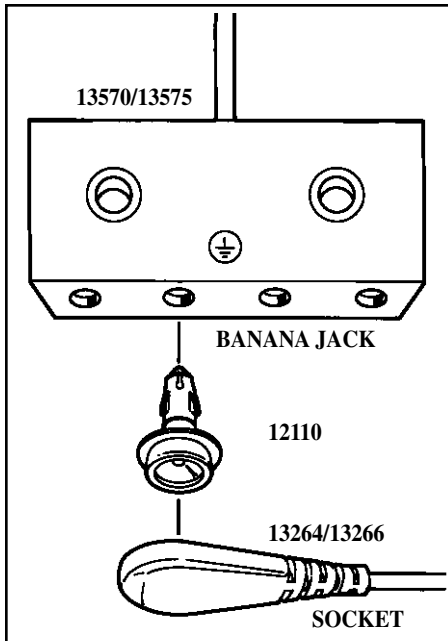

## Limited Warranty

ESD Systems.com expressly warrants that for a period of one (1) year from the date of purchase, ESD Systems.com adapters will be free of defects in material (parts) and workmanship (labor). Within the warranty period, a unit will be tested, repaired or replaced at our option, free of charge. Call Customer Service at 508-485-7390 for a Return Material Authorization (RMA) and proper shipping instructions and address. You should include a copy of your original packing slip, invoice, or other proof of purchase date. Any unit under warranty should be shipped prepaid to the ESD Systems.com factory. Warranty repairs will take approximately two weeks.

## Warranty Exclusions

THE FOREGOING EXPRESS WARRANTY IS MADE IN LIEU OF ALL OTHER PRODUCT WARRANTIES, EXPRESSED AND IMPLIED, INCLUDING MERCHANTABILITY AND FITNESS FOR A PARTICULAR PURPOSE WHICH ARE SPECIFICALLY DISCLAIMED. The express warranty will not apply to defects or damage due to accidents, neglect, misuse, alterations, operator error, or failure to properly maintain, clean or repair products.

## Limit of Liability

In no event will ESD Systems.com or any seller be responsible or liable for any injury, loss or damage, direct or consequential, arising out of the use of or the inability to use the product. Before using, users shall determine the suitability of the product for their intended use, and users assume all risk and liability whatsoever in connection therewith.



Visit our online library of Tech Briefs:  
<http://www.esdsystems.com>



432 NORTHBORO ROAD CENTRAL  
 MARLBORO, MA 01752-3170  
 PHONE (508) 485-7390  
 FAX (508) 480-0257